

SPECIALE NUOVO BRAND

L'AZIENDA OSRAV ADEGUA L'IMMAGINE A MISSION E PROGETTI. ECCO UN'INTERVISTA ESCLUSIVA. LE NOVITÀ DI OSRAV con interventi di Emilio e Guido Ardengo, Sales e Marketing Manager di Osrav Spa.

INNOVATIVE NEW BRAND - OSRAV ALIGNS IMAGE TO COMPANY VISION AND FUTURE PROSPECTS. HERE'S AN EXCLUSIVE INTERVIEW. OSRAV'S NEWS with the contribution of Emilio and Guido Ardengo, respectively Sales and Marketing Managers of Osrav Spa.



Perché oggi un nuovo nome?

Emilio Ardengo: "Nel vissuto del mondo dell' "automotive" Osrav interpreta da tempo ed in modo attivo il mercato, proponendo soluzioni e prodotti con alta componente di servizio.

Nel corso degli anni abbiamo costruito un'immagine forte e stabile, caratterizzata da una grande attenzione alla qualità delle realizzazioni e da grande flessibilità nelle richieste con un sistema di approccio in grado di soddisfare puntualmente i clienti sparsi in tutto il mondo.

La nostra gamma e l'esperienza ci consentono di essere sempre propositivi e di assicurare ad ogni cliente il pacchetto di soluzioni su misura. Oggi con "VITAL suspensions" portiamo a coronamento tutto il lavoro, dotandoci di un brand evocativo e internazionale che bene si adatta a ciò che siamo e facciamo."

Why a new denomination?

Emilio Ardengo: "Osrav has always been an active part of the automotive market, offering solutions and realising products with a high service component.

With time, Osrav has built a strong and solid image of high quality standards for its products and of informed flexibility and punctuality, effectively meeting the demands of its clients worldwide.

The extensive product range and the expertise allow for greater proactive capacity guaranteeing tailor-made packages for each client.

Today with "VITAL suspensions" we crown all the effort and perseverance with an evocative and international new brand which embodies the essence of who we are and what we do"

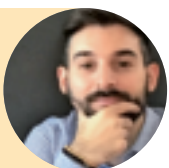

VITAL cosa significa?

Guido Ardengo: "Cinque lettere che caratterizzano... una molteplicità di significati!

Innanzitutto è una parola internazionale cucita a misura della nostra filosofia di lavoro, sempre dinamica e propositiva. Non solo, è anche la nostra missione: fare ammortizzatori che siano "Vital", mantengano la qualità vitale della loro funzione attiva e passiva per una guida a sua volta: Vital!

Ma Vital contiene anche "ital" a suggellare la nostra sincera e fattiva italianità, contiene le iniziali di Vittorio Veneto la città veneta della nostra sede e contiene "Al", iniziale di Alfeo Moret, colui che ha voluto e creato questa azienda nel 1973, e che le ha dato quello spirito di intraprendenza che oggi è il nostro successo."



What does VITAL mean?

Guido Ardengo: "A five letter multiple meaning word!

First of all, it is an international word that perfectly matches our work philosophy always proactive and dynamic. It then represents our company's mission; to produce shock absorbers that are truly VITAL, able to maintain their high quality long lasting active and passive functioning guaranteeing in turn a VITAL driving experience. However, to consolidate the genuine Italian

authenticity that we proudly incorporate, VITAL contains "ITAL", but also the initials of the Venetian city, Vittorio Veneto, where we are located.

Above all, VITAL, includes an essential component, "AL", initials for Alfeo Moret, the father founder of our company, who already in 1973 established this company with a great entrepreneurial spirit and futurist vision which have laid the foundation of our current success."



LA SCELTA MIGLIORE... SU STRADA!

A WINNIG CHOICE...
ON THE ROAD!



SICUREZZA, COMFORT E QUALITÀ

Questa linea di nuovi ammortizzatori con garanzia biennale certificata, vince in sicurezza, comfort e qualità.

Disponibili in una gamma completa, con versioni olio e olio-gas, gli ammortizzatori WKTORY sono riusciti ad anticipare le nuove tecnologie di fabbricazione, presentandosi come la migliore sistemi produttiva per l'aftermarket più sensibile e attento alle novità.

Osrav valorizza ed investe nel proprio reparto di Ricerca & Sviluppo per assicurare un progresso costante, senza porre limiti alla capacità di scoperta e invenzione.

SAFETY, COMFORT AND QUALITY!

This certified range of new shock absorbers with their two-year guarantee is a winner in terms of safety, comfort and quality. In a complete range of oil and gas-oil versions WKTORY shock absorbers have managed to anticipate new manufacturing technologies by presenting the best combined solutions for the after market which is the most sensitive towards innovations.

Osrav invest heavily in its Research and Development division, to ensure constant progress without placing restrictions on the ability to discover and invent.



CONSULTAZIONE CATALOGO

pag. 5

How to look up in the catalogue - Consultation du catalogue - Nachschlage des Katalog - Consulta de catálogo - Consulta de Catálogo

Consultatie van de catalogus - Sådan slår du op i kataloget - Руководство пользователя

ALFA ROMEO	pag. 6	JEEP	pag. 74	SSANG YONG	pag. 158
AUDI	pag. 10	KIA	pag. 76	SUBARU	pag. 159
AUSTIN	pag. 16	LADA	pag. 79	SUZUKI	pag. 161
AUTOBIANCHI	pag. 17	LANCIA	pag. 80	TALBOT	pag. 164
BEDFORD	pag. 18	LAND ROVER	pag. 84	TOYOTA	pag. 166
BMW	pag. 20	MAZDA	pag. 86	VAUXHALL	pag. 175
CHEVROLET	pag. 27	MERCEDES	pag. 90	VOLKSWAGEN	pag. 180
CHRYSLER	pag. 28	MINI	pag. 98	VOLVO	pag. 192
CITROËN	pag. 29	MITSUBISHI	pag. 99	ZASTAVA	pag. 194
DACIA	pag. 36	NISSAN	pag. 104		
DAEWOO - CHEVROLET	pag. 37	OPEL	pag. 113		
DAIHATSU	pag. 38	PEUGEOT	pag. 121		
DR	pag. 39	PIAGGIO	pag. 129		
FIAT	pag. 40	POLSKI	pag. 129		
FORD	pag. 51	PORSCHE	pag. 130		
HONDA	pag. 61	RENAULT	pag. 131		
HYUNDAI	pag. 66	ROVER	pag. 144		
INNOCENTI	pag. 70	SAAB	pag. 146		
ISUZU	pag. 71	SEAT	pag. 148		
IVECO	pag. 72	SKODA	pag. 154		
JAGUAR	pag. 73	SMART	pag. 157		

INFORMAZIONI E DISEGNI TECNICI

pag. 196

technical information and drawings - informations techniques et dessins - technische Informationen und Zeichnungen - información técnica y dibujos - informações técnicas e desenhos - technische informatie en tekeningen - tekniske oplysninger og tegninger - техническая информация и чертежи

CONDIZIONI GENERALI DI VENDITA

pag. 205

General sales term and conditions - Conditions générales de ventes - Allgemeine Verkaufsbedingungen - Condiciones generales de las ventas - Condições Gerais de Venda - Algemene verkoopcondities - Generale salgs konditioner - Основные условия продажи

PRINCIPALI CAUSE DI DANNEGGIAMENTO NON IMPUTABILI A DIFETTOSITÀ DEL PRODOTTO

pag. 207

Principle defects due to improper handling of product

ATTACCHI AMMORTIZZATORI

pag. 209

Shock absorbers end fitting - Type des fixations des amortisseurs - Befestigung der Stossdämpfer - Esquema de anclajes

Diagrama de Montagem de Amortecedores - Bevestigingstype van de schokdemper - Monterings vejledning - Крепления амортизаторов

LEGENDA

pag. 210

Legend - Legende - Bemerkung - Leyenda - Legenda - Legende - Bemærkning - Легенда

NUOVA CONSULTAZIONE CATALOGO

NEW CATALOGUE CONSULTATION - NOUVELLE CONSULTATION SUR LE CATALOGUE -
NEUE KATALOGKONSULTATION - NUEVA CONSULTA DE CATÁLOGO -
NOVA CONSULTA DE CATÁLOGO - NIEUWE CONSULTATIE OVER DE CATALOGUS -
NY CATALOG CONSULTATION - НОВАЯ КОНСУЛЬТАЦИЯ КАТАЛОГА

Coppia ammortizzatori
Double shock absorbers -
Doubles amortisseurs -
Doppelstoßdämpfer
Amortiguadores en pareja
Amortecedores duplos
Dubbele Schokdempers
Dobbel Støtdempere
двойные амортизаторы

Ammortizzatore singolo sinistro
Single left shock absorber
Simple amortisseur gauche
Einzelner Linker Stoßdämpfer
Amortiguador individual izquierdo
Amortecedor esquerdo unico
Enkele Links Schokdemper
Enkelt Venstre Støddæmper
одиночный левый амортизатор

Ammortizzatore singolo destro
Single right shock absorber
Simple amortisseur droit
Einzelner Rechter Stoßdämpfer
Amortiguador individual derecho
Amortecedor direito unico
Enkele Rechts schokdemper
Enkelt Højre Støddæmper
односторонний амортизатор

Supporti gomma & metallo
Strut mount
Semmelle de suspension
Federbeinstützlager
Topes de suspensión
Apoio do amortecedor
Veerpootlager
Stottelager fjaerbein
Крепление стойки амортизатора

Kit di protezione
Protection kit
Kit de protection
Protektion Kit
Kit de proteccìon
Jogo de protecção
Beschermings Kit
Beskyttelsessæt
защитный набор



► BMW (D)

3 SERIES (E46) 4X2

316i, 318i, 320i excl.: M-Sport Pack II	(E46)	02.98 - 09.01		1a		GAS	210185	MG0847	MG0848	600240	516004
				2b				GAS	211318	TG0819.0	600320

Data

Date - Date
Baujahr - Fecha
Data - Bouwjaar
Productions år - Дата

Marca/Costruttore

Manufacturer - Fabricant
Hersteller - Marca/Costrutor
Fabricante - Merk
Fabrikant - Производитель

Specifica Modello

Model specifications - Caractéristiques modèles
Besonderheit - Especificación modelo
Especificação modelo - Model-Specificaties
Model Betegnelse - Объем двигателя

Modello Veicolo

Model - Modèle
Modell - Modelo
Modelo - Model
Model - Модель

Asse Posteriore

Rear wheels - Roues Arrière
Hinterachse - Tren Trasero
Traseria - Achter - Bag Aksel
задняя ось

Tipo di applicazione

Application type - Type de application
Anwendung der Stossdämpfer - Esquema de anclajes
Esquema de Montagem - Bevestiging van de schokdemper
Anvendelse - Вид применения

Note

Note - Notes
Anmerkungen - Anotación
Nota - Opmerkingen
Bemærkning - примечания

Asse Anteriore

Front wheels - Roues Avant
Vorderachse - Tren Delantero
Dianteria - Voor - For Aksel
передняя ось

ALFA ROMEO (I)

ALFA 6

2.0, 2.5 Turbo Diesel	(119)	04.79 - 12.86			±	OIL	201231	T 0101			
					±	GAS	211237	TG0117			

ALFA 33

1.2, 1.3, 1.3 S, 1.5, 1.7 excl. 4X4 1.8 TD excl. 4X4	(905, 905A)	06.83 - 02.87		1A, 2		GAS	210101	MG0103	MG0104			516004
					±	GAS	211233	TG0107				
1.5 4X4	(905, 905A)	06.83 - 02.87				GAS	210108	MG0123	MG0122			516004
					±	GAS	211233	TG0107				
1.2, 1.3, 1.5, 1.7, 1.8 TD	(905, 905A)	03.87 - 01.90		1A		GAS	210101	MG0103	MG0104			516004
					±	GAS	211233	TG0107				
1.3, 1.3 S, 1.4, 1.5, 1.7 excl. 1.7ie 16V, 4X4	(907A, 907B)	01.90 - 01.93		1B		GAS	210102	MG0105	MG0106			516004
					±	GAS	211233	TG0107				
1.7ie 16V 4X2 1.7ie 16V SW 4X2	(907A) (907B)	04.90 - 01.93										
1.7ie 16V 4X4 1.7ie 16V SW 4X4	(907A) (907B)	04.90 - 01.93										
					±	GAS	211233	TG0107				
1.8 TD	(907A, 907B)	04.90 - 01.93										
					±	GAS	211233	TG0107				
1.3, 1.4, 1.5, 1.7 excl. 1.7ie 16V	(907A, 907B)	02.93 - 09.94				GAS	210114	MG0143	MG0144			516004
					±	GAS	211233	TG0107				
1.7ie 16V	(907A, 907B)	02.93 - 09.94				GAS	210114	MG0143	MG0144			516004
					±	GAS	211233	TG0107				

ALFA 75

	(162B)	06.85 - 02.92			±	GAS	211234	TG0108			
					+	GAS	211235	TG0109			

ALFA 90

	(162)	09.84 - 07.87			±	GAS	211234	TG0108			
					+	GAS	211235	TG0109			

ALFA 145

1.3, 1.6, 1.7 16V Boxer	(930)	03.95 - 12.96				GAS	210109	MG0129	MG0128			516004
					∞	GAS	211391	TG1340				
1.4 16V T.S., 1.6 16V T.S. 1.8 16V T.S., 2.0 16V T.S.	(930)	12.96 - 01.01				GAS	210103	MG0110				516004
					∞	GAS	211391	TG1340				
1.9 TDS	(930)	07.94 - 01.01				GAS	210103	MG0110				516004
					∞	GAS	211391	TG1340				
1.9 JTD	(930)	02.99 - 01.01				GAS	210107	MG0114				516004
					∞	GAS	211391	TG1340				

ALFA 146

1.3, 1.6, 1.7 16V Boxer	(930) (930)	03.95 - 12.96				GAS	210109	MG0129	MG0128			516004
					∞	GAS	211391	TG1340				
1.4 16V T.S., 1.6 16V T.S. 1.8 16V T.S., 2.0 16V T.S.	(930) (930)	12.96 - 01.01				GAS	210103	MG0110				516004
					∞	GAS	211391	TG1340				
1.9 TDS	(930)	07.94 - 01.01				GAS	210103	MG0110				516004
					∞	GAS	211391	TG1340				

ALFA ROMEO (I)

1.9 JTD	(930)	02.99 - 01.01				GAS	210107	MG0114			516004
						GAS	211391	TG1340			

ALFA 147

excl. 3.2 GTA	(937)	01.01 - 03.10				GAS	210978	SG0145	600590	516010
						GAS	210116	MG0147	600600	516004
3.2 GTA	(937)	02.03 - 03.10				GAS	210988	SG0168	600590	516010
						GAS	210122	MG0169	600600	516004

ALFA 155

1.6, 1.7, 1.9 TD, 2.0 TD excl. ¶	(167)	01.92 - 12.97				GAS	210103	MG0110			516004
						GAS	211404	TG1375			
1.8 TS, 2.0 TS, excl. ¶	(167)	01.92 - 12.97				GAS	210103	MG0110			516004
						GAS	211404	TG1375			
2.5 V6 excl. ¶	(167)	01.92 - 12.97				GAS	210107	MG0114			516004
						GAS	211404	TG1375			
2.5 TD excl. ¶	(167)	04.93 - 12.97				GAS	210107	MG0114			516004
						GAS	211404	TG1375			
2.0 Turbo 4x4 excl. ¶	(167)	01.92 - 12.97				GAS	210107	MG0114			516004

ALFA 156

excl. ¶ > Ch. 0116245	(932)	09.97 - 10.98				GAS	210975	SG0135	600590	516010
						GAS	210113	MG0136	600600	516004
excl. ¶ Ch. 0116246 >	(932)	10.98 - 09.05				GAS	210975	SG0135	600590	516010
						GAS	210116	MG0147	600600	516004
¶ > Ch. 0116245	(932)	09.97 - 10.98				GAS	210978	SG0145	600590	516010
									600600	516010
¶ Ch. 0116246 >	(932)	10.98 - 09.05				GAS	210978	SG0145	600590	516010
						GAS	210115	MG0146	600600	516004

ALFA 156 SPORTWAGON

excl. ¶	(932)	05.00 - 05.06				GAS	210975	SG0135			516010
						GAS	210116	MG0147			516004

ALFA 159

excl. ¶, Q4	(140)	09.05 - 11.11				GAS	210982	SG0156			516001
						GAS	210983	SG0157			516001
Sportwagon excl. ¶, Q4	(140)	03.06 - 11.11				GAS	210982	SG0156			516001
						GAS	210983	SG0157			516001

ALFA 164

2.0 TS, 2.0 Turbo, 3.0 V6, 2.5 TD excl. ¶ > Ch. 6183988	(164)	01.87 - 04.90		3A		GAS	210104	MG0111			516004
						GAS	210106	MG0113			516004
2.0 TS, 2.0 Turbo, 3.0 V6, 2.5 TD excl. ¶ Ch. 6183989 >	(164)	05.90 - 09.98		3B		GAS	210105	MG0112			516004
						GAS	210106	MG0113			516004

ALFA 166

	(936)	09.98 - 06.07				GAS	210976	SG0137	600590	516001
						GAS	210977	SG0138		516001

ALFA ROMEO (I)

ALFA 1750/2000

GT, GTV, Spider	(105)	03.68 - 07.75			÷	OIL	201239	T 0119			516004
					+	OIL	201241	T 0121			

ALFA SUD

1.2, 1.3, 1.5Ti Sprint, Sprint Veloce 1.3, 1.5Ti	(901) (902A)	06.72 - 12.89			/	OIL	200001	C 0115			516004
					÷	OIL	201236	T 0116			
Sprint, Sprint Ti Alfa 33 susp.	(902A)	01.84 - 12.89		1A, 2	⚡	GAS	210101	MG0103	MG0104		516004
					÷	GAS	211233	TG0107			

ALFETTA

1.6, 1.8, 2.0, 2.0 TD	(116)	07.74 - 12.84			±	OIL	201231	T 0101			
GTV 1.6, 1.8, 2.0, 2.0 Turbo, 2.5	(116)				+	OIL	201232	T 0102			

ARNA

1.2, 1.3, 1.5	(920)	10.84 - 12.86		1A, 2	⚡	GAS	210101	MG0103	MG0104		516004
					÷	GAS	211238	TG0118			

BRERA

excl. ⚡, Q4	(177)	01.06 - 05.11			⚡	GAS	210984	SG0158			516001
					⚡	GAS	210985	SG0159			
⚡ excl. Q4	(177)	03.06 - 05.11									

CROSSWAGON

excl. ⚡		09.05 -			⚡	GAS	210979	SG0150			516010
					⚡	GAS	210117	MG0151			
⚡		03.06 -			⚡	GAS	210980	SG0152			516010
					⚡	GAS	210118	MG0153			

GIULIA

	(105, 115)	06.64 - 12.78			÷	OIL	201239	T 0119			
					+	OIL	201241	T 0121			
RWD excl. ⚡, ⚡, 4WD		03.16 -			⚡	GAS	210989	SG0171	SG0170		516003
					÷	GAS	211246	TG0172			
4WD excl. ⚡, ⚡		03.16 -			⚡	GAS	210991	SG0173	SG0174		516003
					÷	GAS	211247	TG0175			

GIULIETTA

1.3, 1.6, 1.8, 2.0 2.0 TD	(116)	10.77 - 12.85			±	OIL	201231	T 0101			
					+	OIL	201232	T 0102			

GIULIETTA

	(940)	04.10 -			⚡	GAS	210121	MG0165	MG0166		
					±	GAS	211245	TG0167			

GT

excl. 3.2 GTA	(937)	11.03 - 09.10			⚡	GAS	210981	SG0154		600590	516010
					⚡	GAS	210119	MG0155		600600	516004

ALFA ROMEO (I)

3.2 GTA	(937)	11.03 - 09.10				GAS	210988	SG0168	600590	516010
						GAS	210122	MG0169	600600	516004

GTV

1.6, 1.8, 2.0, 2.0 Turbo, 2.5	(116)	07.74 - 12.84			\pm	OIL	201231	T 0101		
					\pm	OIL	201232	T 0102		
2.0, 2.5	(116)	01.85 - 02.87			\pm	GAS	211234	TG0108		
					\pm	GAS	211235	TG0109		516010
1.8 TS, 2.0 TS	(916C)	03.95 - 10.05				GAS	210111	MG0132		516004
						GAS	211243	TG0134		
2.0 V6 Turbo	(916C)	03.95 - 10.05				GAS	210112	MG0133		516004
						GAS	211243	TG0134		
3.0 V6	(916C)	03.95 - 10.05				GAS	212145	MG0148		
						GAS	211243	TG0134		

MITO

excl. 1.4 Bifuel	(955)	09.08 -				GAS	210120	MG0163	MG0162	600500	516004
					$\frac{1}{2}$	GAS	211244	TG0164		600781	600782

MONTREAL

2.6	(105)	12.72 - 03.79			$\frac{1}{2}$	OIL	201239	T 0119		
					\pm	OIL	201241	T 0121		

SPIDER

1.3, 1.6, 1.7, 2.0	(115)	03.66 - 12.93			$\frac{1}{2}$	OIL	201239	T 0119		
					\pm	OIL	201241	T 0121		
1.8 TS, 2.0 TS	(916S)	09.94 - 04.05				GAS	210111	MG0132		516004
						GAS	211243	TG0134		
2.0 Turbo V6, 3.0 V6	(916S)	09.94 - 04.05				GAS	210112	MG0133		516004
						GAS	211243	TG0134		
	(939)	06.06 - 03.11				GAS	210986	SG0160		516001
						GAS	210987	SG0161		516001

AUDI (D)

50

	(86)	08.74 - 07.78		/	OIL	200002	C 0301			516004
				/	GAS	210002	CG0301			516004
				/	OIL	200993	S 0302			516010
				/	GAS	210993	SG0302			516010

80

L, S, LS, GLS, GT	(80, 82, B1)	05.72 - 08.78		/	OIL	200003	C 0303			516004
				/	OIL	200994	S 0304			516010
GTE	(80, 82, B1)	01.76 - 08.78		/	OIL	200003	C 0303			516004
				/	OIL	200994	S 0304			516010
Avant	(80, 82, B1)	01.75 - 08.78		/	OIL	200003	C 0303			516004
				∅	OIL	201249	T 0305			
, excl. Quattro	(81, 85, B2)	09.78 - 08.86		/	GAS	210004	CG0306			516004
				/	GAS	210995	SG0307			516010
Quattro 4X4	(81, 85, B2)	08.84 - 08.86		/	GAS	210004	CG0306			516004
				/						516004
excl. Quattro,	(89, 89Q, 8A, B3)	06.86 - 07.91		/	GAS	210004	CG0306			516004
				/	GAS	210995	SG0307			516010
excl. Quattro	(89, 89Q, 8A, B3)	06.86 - 07.91		/	GAS	210004	CG0306			516004
				/						516010
Quattro 4X4	(89, 89Q, 8A, B3)	09.86 - 07.91		/	GAS	210004	CG0306			516004
				/						516004
excl. Quattro, excl. 2.6 V6, 2.8 V6, S2,	(8C, B4)	08.91 - 09.94		/	GAS	210004	CG0306			516004
				/	GAS	210997	SG0310			516010
2.6 V6, 2.8 V6 excl.	(8C, B4)	08.91 - 09.94		/	GAS	210004	CG0306			516004
				/	GAS	210997	SG0310			516010
	(8C, B4)	08.91 - 09.94		/	GAS	210004	CG0306			516004
				/						516010
Quattro 4X4	(8C, B4)	08.91 - 09.94		/	GAS	210004	CG0306			516004
				∅						
Avant excl. 2.6 V6, 2.8 V6 excl. Quattro,	(8C, B4)	08.91 - 09.95		/	GAS	210004	CG0306			516004
				/	GAS	210997	SG0310			516010
Avant 2.6 V6, 2.8 V6 excl. RS2,	(8C, B4)	08.91 - 09.95		/	GAS	210004	CG0306			516004
				/	GAS	210997	SG0310			516010
Avant Quattro 4X4	(8C, B4)	08.91 - 09.95		/	GAS	210004	CG0306			516004
				∅						
Avant	(8C, B4)	08.91 - 09.95		/	GAS	210004	CG0306			516004
				/						516010

90

excl. Quattro	(81, 85, B2)	10.84 - 03.87		/	GAS	210004	CG0306			516004
				/	GAS	210995	SG0307			516010
Quattro 4X4	(81, 85, B2)	08.85 - 03.87		/	GAS	210004	CG0306			516004
				/						
excl. 2.3, Quattro,	(89, 89Q, 8A, B3)	04.87 - 07.91		/	GAS	210004	CG0306			516004
				/	GAS	210995	SG0307			516010
excl. 2.3, Quattro	(89, 89Q, 8A, B3)	04.87 - 07.91		/	GAS	210004	CG0306			516004
				/						

AUDI (D)

Quattro 4X4	(89, 89Q, 8A, B3)	04.87 - 07.91			/	GAS	210004	CG0306			516004
					/						

100

1.6, 1.8, 2.2 Avant 1.6, 1.8, 2.2	(43, C2)	06.76 - 08.83			/	GAS	210005	CG0326			
					∅	GAS	211250	TG0312			516010
excl. Quattro Avant excl. Quattro	(44, 44Q, C3)	09.82 - 10.90			/	GAS	210005	CG0326			
				excl.	∅	GAS	210998	SG0313			516010
Quattro 4X4	(44, 44Q, C3)	10.84 - 10.90			/	GAS	210005	CG0326			
				excl.	∅						516010
excl. Quattro, S4 V8 Avant excl. Quattro, S4 V8	(4A, C4)	11.90 - 10.94			/	GAS	210005	CG0326			
				excl.	∅	GAS	210998	SG0313			516010
Quattro 4X4 excl. S4 V8 Avant Quattro 4X4 excl. S4 V8	(4A, C4)	11.90 - 10.94			/	GAS	210005	CG0326			
				excl.	∅						516010

200

	(43, C2)	10.79 - 08.82			/	GAS	210005	CG0326			
					∅	GAS	211250	TG0312			516010
excl. Quattro	(44, 44Q, C3)	06.83 - 10.90			/	GAS	210005	CG0326			
				excl.	∅	GAS	210998	SG0313			516010
Quattro 4X4	(44, 44Q, C3)	10.84 - 10.90			/	GAS	210005	CG0326			
					∅						516010

A1

excl. S line	(8X1)	05.10 -			∅	GAS	210689	MG3719	600270	516004
					∅	GAS	211843	TG3720		516010
Sportback	(8XA)	09.11 -			∅	GAS	210689	MG3719	600270	516004
					∅	GAS	211843	TG3720		516010

A2

1.4 16V, 1.6 16V, 1.4 Tdi excl. , 1.2 Tdi	(8Z)	02.00 - 08.05		4A	∅	GAS	210694	MG3810	600350	516004
					∅	GAS	211257	TG0331		516010
1.4 16V, 1.6 16V, 1.2 Tdi, 1.4 Tdi	(8Z)	02.00 - 08.05		4B	∅	GAS	210126	MG0330		516004
					∅	GAS	211257	TG0331		516010

A3

excl. Quattro,	(8L1)	09.96 - 05.03			∅	GAS	210124	MG0316	600270	516004
					∅	GAS	211251	TG0317	600290	516010
 excl. Quattro	(8L1)	09.96 - 05.03			∅	GAS	210124	MG0316	600270	516004
					∅	GAS	211252	TG0320	600290	516010
Quattro 4X4 excl. , S3	(8L1)	12.96 - 06.99			∅	GAS	210124	MG0316	600270	516004
					∅	GAS	211256	TG0329	600290	
Quattro 4X4, excl. S3	(8L1)	07.99 - 05.03			∅	GAS	210125	MG0327	600270	516004
					∅	GAS	211256	TG0329	600290	

A3 II

incl. Sportback 4X2 Quattro 4X4 excl. ,	(8P1, 8PA)	05.03 - 08.12		5A	∅	GAS	210776	MG4455	600430	516007
				5B	∅	GAS	210127	MG0343		516004
					∅	GAS	211916	TG4456		516010

AUDI (D)

excl.	(8P1, 8PA)	05.03 - 08.12		5A		GAS	210777	MG4457	600430	516007
				5B		GAS	210128	MG0345		516004
						GAS	211260	TG0344		516010

A3 III

excl. 4X4, S3,	(8V1)	04.12 -		5A		GAS	210785	MG4474		516007
				5B		GAS	210784	MG4471		516004
						GAS	211924	TG4472		516010
4X4 excl. S3,	(8V1)	04.12 -		5A		GAS	210785	MG4474		516007
				5B		GAS	210784	MG4471		516004
						GAS	211925	TG4473		516010
Sportback excl. 4X4, S3,	(8VA)	09.12 -		5A		GAS	210785	MG4474		516007
				5B		GAS	210784	MG4471		516004
						GAS	211924	TG4472		516010
Sportback 4X4 excl. S3,	(8VA)	09.12 -		5A		GAS	210785	MG4474		516007
				5B		GAS	210784	MG4471		516004
						GAS	211925	TG4473		516010
Limousine excl. 4X4, S3,	(8VS)	05.13 -		5A		GAS	210785	MG4474		516007
				5B		GAS	210784	MG4471		516004
						GAS	211924	TG4472		516010
Limousine 4X4 excl. S3,	(8VS)	05.13 -		5A		GAS	210785	MG4474		516007
				5B		GAS	210784	MG4471		516004
						GAS	211925	TG4473		516010

A4 (8D)

excl. Quattro,	(8D, B5)	10.94 - 01.99				GAS	210999	SG0314	600060	516001
						GAS	211000	SG0315		516010
excl. Quattro,	(8D, B5)	02.99 - 10.00				GAS	210999	SG0314	600060	516001
						GAS	211006	SG0336		516010
excl. Quattro	(8D, B5)	10.94 - 01.99				GAS	211001	SG0321	600060	516001
						GAS	211000	SG0315		516010
excl. Quattro	(8D, B5)	02.99 - 10.00				GAS	211001	SG0321	600060	516001
						GAS	211006	SG0336		516010
Quattro 4X4 excl.	(8D, B5)	10.94 - 10.00				GAS	210999	SG0314	600060	516001
						GAS	211007	SG0338		
Quattro 4X4,	(8D, B5)	10.94 - 10.00				GAS	211001	SG0321	600060	516001
						GAS	211007	SG0338		

A4 II (8E)

excl.	(8E, B6)	11.00 - 12.04				GAS	211004	SG0332	600760	516001
						GAS	211258	TG0334		516010
excl.	(8E, B6)	11.00 - 12.04				GAS	211005	SG0333	600760	516001
						GAS	211259	TG0335		516010
excl. Quattro	(8E, B7)	11.04 - 06.08				GAS	211012	SG0346	600760	516001
						GAS	211261	TG0347		516010
excl. Quattro	(8E, B7)	11.04 - 06.08				GAS	211016	SG0352		516001
						GAS	211263	TG0353		516010
Quattro excl.	(8E, B7)	11.04 - 06.08				GAS	211013	SG0348	600760	516001
						GAS	211263	TG0353		516010

AUDI (D)

Quattro	(8E, B7)	11.04 - 06.08				GAS	211013	SG0348	600760	516001
						GAS	211265	TG0360		516010

A4 III (8K) EXCL. ALLROAD

excl.	(8K2, 8K5)	11.07 - 12.15				GAS	211018	SG0356		516003
						GAS	211264	TG0357		516010
	(8K2, 8K5)	11.07 - 12.15				GAS	211021	SG0361		516003
						GAS	211266	TG0362		516010

A5

excl.	(8T, 8F)	06.07 - 01.17				GAS	211018	SG0356		516003
						GAS	211264	TG0357		516010
	(8T, 8F)	06.07 - 01.17				GAS	211021	SG0361		516003
						GAS	211266	TG0362		516010

A6 (4A)

excl. Quattro, S6	(4A, C4)	06.94 - 02.97				GAS	210005	CG0326		516004
						GAS	210998	SG0313		516001
Avant excl. Quattro, S6	(4A, C4)	06.94 - 12.97				GAS	210005	CG0326		516004
						GAS	210998	SG0313		516001
Quattro excl. S6, Avant Quattro excl. S6,	(A4, C4)	06.94 - 12.97				GAS	210005	CG0326		516004
						GAS	211019	SG0358		516001
Quattro excl. S6, Avant Quattro excl. S6,	(A4, C4)	06.94 - 12.97				GAS	210005	CG0326		516004
						GAS	211020	SG0359		516001

A6 II (4B)

excl. Quattro,	(4B, C5)	01.97 - 01.99				GAS	211002	SG0322	600060	516001
						GAS	211253	TG0323		516010
excl. Quattro, > Ch. 4B-X-070000	(4B, C5)	12.97 - 01.99				GAS	211002	SG0322	600060	516001
						GAS	211253	TG0323		516010
excl. Quattro > Ch. 4B-X-070000	(4B, C5)	05.97 - 01.99				GAS	211001	SG0321	600060	516001
						GAS	211253	TG0323		516001
Quattro 4X4 > Ch. 4B-X-070000	(4B, C5)	05.97 - 01.99				GAS	211002	SG0322	600060	516001
						GAS	211010	SG0341		516010
excl. Quattro, Ch. 4B-X-070001 > Ch. 4B-Y-200000	(4B, C5)	01.99 - 04.00				GAS	211002	SG0322	600060	516001
						GAS	211253	TG0323		516010
excl. Quattro Ch. 4B-X-070001 > Ch. 4B-Y-200000	(4B, C5)	01.99 - 04.00				GAS	211001	SG0321	600060	516001
						GAS	211253	TG0323		516001
Quattro 4X4 Ch. 4B-X-070001 > Ch. 4B-Y-200000	(4B, C5)	01.99 - 04.00				GAS	211002	SG0322	600060	516001
						GAS	211010	SG0341		516010
excl. Quattro, Ch. 4B-1-000001 >	(4B, C5)	05.00 - 04.04				GAS	211008	SG0339	600060	516001
						GAS	211253	TG0323		516010
excl. Quattro Ch. 4B-1-000001 >	(4B, C5)	05.00 - 04.04				GAS	211009	SG0340	600060	516001
						GAS	211253	TG0323		516010
Quattro 4X4 excl. Ch. 4B-1-000001 >	(4B, C5)	05.00 - 04.04				GAS	211008	SG0339	600060	516001
						GAS	211011	SG0342		516001

A6 III (4F) EXCL. ALLROAD

excl. Quattro,	(4F2, C6)	05.04 - 03.11				GAS	211014	SG0350		516001
						GAS	211262	TG0349		516010

AUDI (D)

excl. Quattro,	(4F5, C6)	03.05 - 08.11				GAS	211014	SG0350			516001
							GAS	211262	TG0349		
excl. Quattro	(4F2, C6)	05.04 - 03.11				GAS	211017	SG0354			516001
							GAS	211262	TG0349		
excl. Quattro	(4F5, C6)	03.05 - 08.11				GAS	211017	SG0354			516001
							GAS	211262	TG0349		
Quattro excl.	(4F2, C6)	05.04 - 03.11				GAS	211015	SG0351			516001
							GAS	211262	TG0349		
Quattro excl.	(4F5, C6)	03.05 - 08.11				GAS	211015	SG0351			516001
							GAS	211262	TG0349		

A6 IV (4G) EXCL. ALLROAD

excl.	(4G2, C7, 4GC)	03.11 -									516003
							GAS	211266	TG0362		
excl.	(4G5, C7, 4GC)	05.11 -									516003
							GAS	211266	TG0362		
	(4G2, C7, 4GC)	03.11 -									516003
	(4G5, C7, 4GC)	05.11 -									516003

A8

excl.	(4D2, 4D8)	06.94 - 12.98				GAS	211003	SG0324		600060	
							GAS	211254	TG0325		

CABRIOLET

	(8G7, B4)	08.91 - 08.00				GAS	210004	CG0306			516004

COUPÉ

excl. Quattro	(81, 85)	08.80 - 09.88				GAS	210004	CG0306			516004
							GAS	210995	SG0307		
excl. Quattro, S2	(89, 8B)	10.88 - 07.91				GAS	210004	CG0306			516004
Quattro 4X4	(81, 85, 89, 8B)	01.84 - 07.91				GAS	210004	CG0306			516004
excl. Quattro, S2,	(89, 8B)	08.91 - 12.96				GAS	210004	CG0306			516004
Quattro 4X4	(89, 8B)	08.91 - 12.96				GAS	210004	CG0306			516004

Q3

excl. RS,	(8U)	06.11 -				GAS	210782	MG4467		600430	516007
							GAS	211922	TG4468		

Q5

excl. S line	(8R)	11.08 -				GAS	211018	SG0356			516003
							GAS	211264	TG0357		

AUDI (D)

TT

4X2 excl. 3.2 V6	(8N3, 8N9)	10.98 - 10.06			GAS	210125	MG0327	600270	516004
					GAS	211255	TG0328	600290	516010
Quattro 4X4 excl. 3.2 V6	(8N3, 8N9)	10.98 - 10.06			GAS	210125	MG0327	600270	516004
					GAS	211256	TG0329	600290	
excl. S line	(8J3)	10.06 - 06.14			GAS	210129	MG0363	600430	516007
					GAS	211267	TG0364		516010
excl. S line	(8J9)	02.07 - 06.14			GAS	210129	MG0363	600430	516007
					GAS	211267	TG0364		516010
excl.	(FV3)	07.14 -			GAS	210785	MG4474		516007
					GAS	211925	TG4473		516010
excl.	(FV3)	07.14 -			GAS	210785	MG4474		516007
					GAS	211925	TG4473		516010

V8

3.6, 4.2	(D1)	10.88 - 02.94			GAS	210005	CG0326		516004

AUSTIN (GB)

MAESTRO

excl. 2.0 MG EFI, Turbo,	(XC)	1983 - 1994		6A		GAS	210130	MG0401			
				6B		GAS	210131	MG0402			
				6D		GAS	211022	SG0403			
				6E		GAS	211023	SG0404			
2.0 MG EFI, Turbo	(XC)	1984 - 1994		6A		GAS	210130	MG0401			
				6B		GAS	210131	MG0402			
				6D		GAS	211022	SG0403			
				6E		GAS	211023	SG0404			
	(XC)	1985 - 1990		6C		OIL	200132	M 0405			
						OIL	201268	T 0406			
	(XC)	1990 - 1994		6C		OIL	200132	M 0405			
						OIL	201269	T 0407			

METRO

		1980 - 1990				OIL	201270	T 0408			

MINI

0.85, Cooper, Cooper S 0.85, 1.0, 1.1, 1.3, GT, Cooper		1965 - 1969				OIL	201271	T 0409			
		1970 - 1981				OIL	201273	T 0411			
Innocenti		1974 - 1981				OIL	201271	T 0409			
						OIL	201273	T 0411			
, ,		1961 - 1981				OIL	201271	T 0409			
						OIL	201272	T 0410			
		1961 - 1981				OIL	201271	T 0409			

MONTEGO

excl. 2.0 MG Turbo,	(XE)	04.84 - 12.94		6A		GAS	210130	MG0401			
				6B		GAS	210131	MG0402			
				6D		GAS	211022	SG0403			
				6E		GAS	211023	SG0404			
2.0 MG Turbo excl.	(XE)	1985 - 02.87		6A		GAS	210130	MG0401			
						GAS	211024	SG0412			
2.0 MG Turbo		03.87 - 1994		6B		GAS	210131	MG0402			
excl.	(XE)	10.84 - 12.94		6A		GAS	210130	MG0401			
				6B		GAS	210131	MG0402			
						GAS					
						GAS					

AUTOBIANCHI (I)

A 112

ch. 47201>		1969 - 1987				OIL	200133	M 0503			
						OIL	200134	M 0504			

Y 10

4X2	(156)	03.85 - 1992				OIL	200135	M 0505	M 0506			516004
						GAS	210135	MG0505	MG0506			
						OIL	201714	T 0507				
						GAS	211714					
4X2	(156)	1933 - 1996				OIL	200135	M 0505	M 0506			516004
						GAS	210135	MG0505	MG0506			
						OIL	201276	T 0509				
						GAS	211276	TG0509				
4X4	(156)	03.85 - 1992				OIL	200135	M 0505	M 0506			516004
						GAS	210135	MG0505	MG0506			
						OIL	201275	T 0508				
						GAS	211275	TG0508				
4X4	(156)	1933 - 1996				OIL	200135	M 0505	M 0506			516004
						GAS	210135	MG0505	MG0506			
						GAS	211277	TG0510				

BEDFORD (GB)

ASTRA

Astra		1982 - 1984		/	GAS	210046	CG2927			
				♀	OIL	201678	T 2928			
Astra		1984 - 07.91		/	OIL	210046	CG2927			
				♀	OIL	201664	T 2909			
AstraMax		1985 - 07.91		/	OIL	210046	CG2927			
				♀	OIL	201679	T 2929			

CF

14, 18, 22, 25, 35 CWT		1970 - 1975		+	OIL	201665	H 2910			
				♀	OIL	201312	T 0703			
220, 250, 280, 340		1976 - 1982		+	OIL	201665	H 2910			
				♀	OIL	201666	H 2911			
350		1976 -		+	OIL	201665	H 2910			
				♀						
CF 18, 22, 25 CWT		1984 -		+	OIL	201313	H 0705			
				♂	OIL	201665	H 2910			
				♀	OIL	201377	T 1303			
35 CWT		1983 - 1984		+	OIL	201665	H 2910			
				♀	OIL	201666	H 2911			
35 CWT		1984 -		♂	OIL	201313	H 0705			
				♀	OIL	201666	H 2911			
CF 97170/97370				+	OIL	201313	H 0705			
				♂	OIL	201665	H 2910			
				♀	OIL	201377	T 1303			
CF 97170/97370				♂	OIL	201313	H 0705			
				+	OIL	201665	H 2910			
				♀	OIL	201666	H 2911			

CHEVANNE

9 CWT		1976 -		♂	GAS	201661	T 2903			
				♂	GAS	211674	TG2921			

KB

		1980 -		♂	GAS	211489	HG1901			
				♀	GAS	211596	HG2616			

MIDI

4X2		1985 -		♂	OIL	201311	H 0701			
				♀	GAS	211499	HG2106			
4X4		1985 -		♂						
				♀	GAS	211499	HG2106			

RASCAL

		1986 -		♂	OIL	200178	M 0709	M 0708		
				♀	OIL	201314	H 0706			
		1986 -		♂	OIL	200178	M 0709	M 0708		
				♀	OIL	201315	H 0707			

BMW (D)

1 SERIES (E81, E82, E87, E88)

116i, 118i, 120i, 130i excl. 116d, 118d, 120d, 123d excl.	(E81, E87)	09.04 - 09.12				GAS	210190	MG0863	MG0864	600240	516004
					+	GAS	211325	TG0865			516001
120i, 125i, 135i, 118d, 120d, 123d excl. 3.0 M,	(E82)	10.07 - 10.13				GAS	210190	MG0863	MG0864	600240	516004
					+	GAS	211325	TG0865			516001
118i, 120i, 125i, 135i, 118d, 120d, 123d excl.	(E88)	03.08 - 12.13				GAS	210190	MG0863	MG0864	600240	516004
					+	GAS	211325	TG0865			

1 SERIES (F20, F21) EXCL. M-TECHNIK

excl. , xDrive	(F20)	12.10 -				GAS	210945	MG6128			516004
					+	GAS	212065	TG6129			516001
excl. , xDrive	(F21)	12.11 -				GAS	210945	MG6128			516004
					+	GAS	212065	TG6129			516001

2 SERIES (F22, F23) EXCL. M-TECHNIK

excl.	(F22)	10.12 -				GAS	210945	MG6128			516004
					+	GAS	212065	TG6129			516001
excl.	(F23)	03.14 -				GAS	210945	MG6128			516004
					+	GAS	212065	TG6129			516001

3 SERIES (E21)

excl. 323i,	(E21)	06.75 - 08.82				OIL	200008	C 0805			516004
					+	OIL	201026	S 0806			
 323i	(E21)	06.75 - 08.82 09.77 - 08.82				GAS	210009	CG0807			516004
					+	GAS	211026	SG0806			

3 SERIES (E30) EXCL. M-TECHNIK

316, 318, 320, 324 D excl.	(E30)	09.82 - 09.87		7A		GAS	210010	CG0808			516004
					+	GAS	211317	TG0809	600320		
316, 318, 320, 324 D 	(E30)	09.82 - 09.87		7B		GAS	210011	CG0810			516004
					+	GAS	211317	TG0809	600320		
323i 325e, 325i	(E30)	09.82 - 09.87 02.85 - 09.87		7B		GAS	210011	CG0810			516004
					+	GAS	211317	TG0809	600320		
325iX 4X4 excl.	(E30)	09.85 - 08.91									516004
					+	GAS	211317	TG0809	600320		
318i, 320i, 325i	(E30)	12.85 - 10.93		7B		GAS	210011	CG0810			516004
					+	GAS	211317	TG0809	600320		
316i, 318i, 318is, 320i, 324 D excl.	(E30)	10.87 - 08.90		7A		GAS	210010	CG0808			516004
					+	GAS	211317	TG0809	600320		
316i, 318i, 318is, 320i, 324 D 	(E30)	10.87 - 08.90		7B		GAS	210011	CG0810			516004
					+	GAS	211317	TG0809	600320		
320is, 325i, 325e 324 TD	(E30)	10.87 - 08.90 10.87 - 08.90		7B		GAS	210011	CG0810			516004
					+	GAS	211317	TG0809	600320		
Touring 316i excl. Touring 318i excl.	(E30)	10.87 - 06.94 10.87 - 06.94		7A		GAS	210010	CG0808			516004
					+	GAS	211317	TG0809	600320		
Touring 318is, 320i, 320is, 325i, 325is Touring 324 TD	(E30)	10.87 - 06.94 10.87 - 06.94		7B		GAS	210011	CG0810			516004
					+	GAS	211317	TG0809	600320		

BMW (D)

3 SERIES (E36) EXCL. M-TECHNIK

316i, 318i, 318is	(E36)	11.90 - 05.92		8A		GAS	210179	MG0811	MG0812			516004
						+	GAS	211318	TG0819		600320	516001
320i, 325i, 325 TD, 320i, 325i	(E36)	11.90 - 05.92		8B		GAS	210180	MG0813	MG0814			516004
						+	GAS	211318	TG0819		600320	516001
316i, 318i, 318is, 318 TDS	(E36)	06.92 - 02.98		8C		GAS	210181	MG0815	MG0816			516004
						+	GAS	211318	TG0819		600320	516001
320i, 323i, 325i, 328i, 325 TD, 325 TDS	(E36)	06.92 - 02.98		8D		GAS	210182	MG0817	MG0818			516004
						+	GAS	211318	TG0819		600320	516001
316i, 318is	(E36)	06.92 - 02.98		8C		GAS	210181	MG0815	MG0816			516004
						+	GAS	211318	TG0819		600320	516001
320i, 323i, 325i, 328i	(E36)	06.92 - 02.98		8D		GAS	210182	MG0817	MG0818			516004
						+	GAS	211318	TG0819		600320	516001
Compact 316i, 318Ti, 318 TDS	(E36)	03.94 - 08.00		8C		GAS	210181	MG0815	MG0816			516004
						+	GAS	211319	TG0834			516001
318i, 320i, 323i, 325i, 328i	(E36)	03.93 - 04.99		8D		GAS	210182	MG0817	MG0818			516004
						+	GAS	211318	TG0819		600320	516001
Touring 316i, 318i, 320i, 325i, 328i, 325 TD, 325 TDS	(E36)	01.95 - 10.99		8C		GAS	210181	MG0815	MG0816			516004
						+	GAS	211320	TG0835			516001

3 SERIES (E46) 4X2

316i, 318i, 320i excl. M-Sport Pack II	(E46)	02.98 - 09.01				GAS	210185	MG0847	MG0848	600240	516004
						+	GAS	211318	TG0819		600320
316i, 318i, 318d excl. M-Sport Pack II	(E46)	09.01 - 04.05				GAS	210191	MG0867	MG0866	600240	516004
						+	GAS	211318	TG0819		600320
320i, 320d, 325i excl. M-Sport Pack II	(E46)	09.01 - 04.05				GAS	210192	MG0869	MG0868	600240	516004
						+	GAS	211332	TG0886		600320
330i, 330d incl. M-Sport Pack II	(E46)	06.00 - 04.05				GAS	210186	MG0851	MG0852	600240	516004
						+	GAS	211331	TG0885		600320
316i, 318i, 320i, 325i excl. M-Sport Pack II	(E46)	02.98 - 09.01				GAS	210193	MG0871	MG0870	600240	516004
						+	GAS	211329	TG0883		600320
320d excl. M-Sport Pack II	(E46)	02.98 - 09.01				GAS	210186	MG0851	MG0852	600240	516004
						+	GAS	211331	TG0885		600320
316i, 318i, 318d excl. M-Sport Pack II	(E46)	09.01 - 04.05				GAS	210193	MG0871	MG0870	600240	516004
						+	GAS	211329	TG0883		600320
320i, 325i, 320d excl. M-Sport Pack II	(E46)	09.01 - 04.05				GAS	210197	MG0881	MG0882	600240	516004
						+	GAS	211331	TG0885		600320
316Ci, 318Ci excl. M-Sport Pack II	(E46)	04.00 - 04.05				GAS	210193	MG0871	MG0870	600240	516004
						+	GAS	211329	TG0883		600320
320Ci excl. M-Sport Pack II	(E46)	04.99 - 04.01				GAS	210192	MG0869	MG0868	600240	516004
						+	GAS	211329	TG0883		600320
320 Ci excl. M-Sport Pack II	(E46)	04.01 - 09.01				GAS	210192	MG0869	MG0868	600240	516004
						+	GAS	211331	TG0885		600320
320 Ci excl. M-Sport Pack II	(E46)	10.01 - 04.05				GAS	210197	MG0881	MG0882	600240	516004
						+	GAS	211331	TG0885		600320
323Ci, 325Ci, 328Ci excl. M-Sport Pack II	(E46)	04.99 - 09.01				GAS	210192	MG0869	MG0868	600240	516004
						+	GAS	211330	TG0884		600320
330Ci excl. M-Sport Pack II	(E46)	06.00 - 04.01				GAS	210192	MG0869	MG0868	600240	516004
						+	GAS	211330	TG0884		600320

BMW (D)

330Ci excl.	(E46)	04.01 - 09.01				GAS	210192	MG0869	MG0868	600240	516004
						GAS	211331	TG0885		600320	516001
330Ci, 330Cd excl.	(E46)	09.01 - 04.05 03.03 - 04.05				GAS	210197	MG0881	MG0882	600240	516004
						GAS	211331	TG0885		600320	516001
320Ci, 325Ci, 330Ci excl.	(E46)	04.99 - 09.01									
						GAS	211331	TG0885		600320	516001
320Ci, 325Ci, 330Ci excl.	(E46)	09.01 - 04.05				GAS	210186	MG0851	MG0852	600240	516004
						GAS	211331	TG0885		600320	516001
323Ci, 328Ci excl.	(E46)	04.99 - 09.00				GAS	210186	MG0851	MG0852	600240	516004
						GAS	211331	TG0885		600320	516001
Touring 316i, 318i, 318d excl.	(E46)	10.99 - 02.05				GAS	210191	MG0867	MG0866	600240	516004
						GAS	211330	TG0884		600320	516001
Touring 320i, 323i, 325i, 328i, 330i Touring 320d, 330d excl.	(E46)	10.99 - 02.05 03.00 - 02.05				GAS	210192	MG0869	MG0868	600240	516004
						GAS	211330	TG0884		600320	516001
Touring 316i, 318i, 320i, 323i, 325i, 328i, 330i Touring 318d, 320d, 330d excl.	(E46)	10.99 - 02.05 10.99 - 02.05				GAS	210193	MG0871	MG0870	600240	516004
						GAS	211330	TG0884		600320	516001
318Ci, 320Ci, 323Ci, 325Ci, 330Ci, 320Cd excl.	(E46)	04.00 - 04.05				GAS	210192	MG0869	MG0868	600240	516004
						GAS	211330	TG0884		600320	516001
318Ci, 320Ci, 323Ci, 325Ci, 330Ci, 320Cd excl.	(E46)	04.00 - 09.01				GAS	210193	MG0871	MG0870	600240	516004
						GAS	211330	TG0884		600320	516001
318Ci, 320Ci, 323Ci, 325Ci, 330Ci, 320Cd excl.	(E46)	09.01 - 04.05				GAS	210186	MG0851	MG0852	600240	516004

3 SERIES COMPACT (E46)

316ti, 318ti excl.	(E46)	06.01 - 02.05				GAS	210185	MG0847	MG0848	600240	516004
						GAS	211318	TG0819		600320	516001
325ti, 320td excl.	(E46)	06.01 - 02.05				GAS	210192	MG0869	MG0868	600240	516004
						GAS	211332	TG0886		600320	516001
316ti, 318ti 	(E46)	06.01 - 03.02				GAS	210185	MG0847	MG0848	600240	516004
						GAS	211329	TG0883		600320	516001
316ti, 318ti 	(E46)	03.02 - 03.03				GAS	210192	MG0869	MG0868	600240	516004
						GAS	211318	TG0819		600320	516001
316ti, 318ti 	(E46)	03.03 - 02.05				GAS	210193	MG0871	MG0870	600240	516004
						GAS	211318	TG0819		600320	516001
325ti, 320td 	(E46)	06.01 - 09.01				GAS	210186	MG0851	MG0852	600240	516004
						GAS	211331	TG0885		600320	516001
325ti, 320td 	(E46)	09.01 - 02.05				GAS	210197	MG0881	MG0882	600240	516004
						GAS	211331	TG0885		600320	516001

3 SERIES (E90) EXCL. M-TECHNIK

316i, 320i, 320d, 323i, 325i excl. xi, xd, xDrive, 318i, 330i, 318d, 330d excl. xi, xd, xDrive,	(E90)	01.05 - 12.11				GAS	210198	MG0887	MG0888	600240	516004
						GAS	211333	TG0889			516001

3 SERIES TOURING (E91) EXCL. M-TECHNIK

320i, 325i, 330i excl. xi, xd, xDrive, 320d, 330d excl. xi, xd, xDrive,	(E91)	01.05 - 06.12 09.05 - 06.12				GAS	210198	MG0887	MG0888	600240	516004
						GAS	211333	TG0889			516001

3 SERIES (E92) EXCL. M-TECHNIK

320i, 325i, 330i, 335i excl. xi, xd, xDrive, 320d, 325d, 330d, 335d excl. xi, xd, xDrive,	(E92)	06.06 - 12.13				GAS	210198	MG0887	MG0888	600240	516004
						GAS	211333	TG0889			516001

BMW (D)

3 SERIES (E93) EXCL. M-TECHNIK

320i, 325i, 330i, 335i excl. xi, xd, xDrive, 320d, 325d, 330d, excl. xi, xd, xDrive,	(E93)	08.06 - 12.13				GAS	210198	MG0887	MG0888	600240	516004
					+	GAS	211333	TG0889			516001

3 SERIES (F30, F80)

excl. xDrive, Active Hybrid	(F30, F80)	10.11 -				GAS	210946	MG6130			516004
					+	GAS	212066	TG6131			516001

3 SERIES (F31)

excl. xDrive, Active Hybrid	(F31)	06.12 -				GAS	210946	MG6130			516004
					+	GAS	212066	TG6131			516001

3 SERIES GRAN TURISMO (F34)

excl. xDrive, Active Hybrid	(F34)	03.13 -				GAS	210946	MG6130			516004
					+	GAS	212066	TG6131			516010

4 SERIES (F32, F33, F36)

excl. xDrive,	(F32, F82)	07.13 -				GAS	210946	MG6130			516004
					+	GAS	212066	TG6131			516001
excl. xDrive,	(F33, F83)	10.13 -				GAS	210946	MG6130			516004
					+	GAS	212066	TG6131			516001
Gran coupè excl. xDrive,	(F36)	03.14 -				GAS	210946	MG6130			516004
					+	GAS	212066	TG6131			516001

5 SERIES (E12)

518, 520, 520A, 520i, 525 525A, 528, 528A, 530i, 530iA	(E12)	08.72 - 07.76				GAS	210007	CG0803			516004
					+						
518, 520, 520A, 520i, 518i, 520/6, 525 525i, 528, 528A, 528i, 528iA, 530i, 530iA	(E12)	08.76 - 06.81				GAS	210007	CG0803			516004
					+	GAS	211027	SG0820			

5 SERIES (E28) EXCL. M-TECHNIK

518, 518i, 520i, 525i, 528i 524 D, 524 TD, 525e	(E28)	07.81 - 12.87				GAS	210012	CG0821			516004
					+	GAS	211028	SG0822			

5 SERIES (E34) EXCL. M-TECHNIK

518i excl. , ,	(E34)	01.88 - 07.90		9A		GAS	210013	CG0823			516004
					+	GAS	211029	SG0824			516010
518i excl. ,	(E34)	01.88 - 07.90		9C		GAS	210014	CG0825			516004
					+	GAS	211029	SG0824			516010
518i excl. , ,	(E34)	08.90 - 09.95		9B		GAS	210020	CG0833			516004
					+	GAS	211029	SG0824			516010
518i excl. ,	(E34)	08.90 - 08.92		9D		GAS	210015	CG0826			516004
					+	GAS	211029	SG0824			516010
518i excl. ,	(E34)	09.92 - 09.95		9B		GAS	210020	CG0833			516004
					+	GAS	211029	SG0824			516010
520i excl. , ,	(E34)	01.88 - 07.90		9A		GAS	210013	CG0823			516004
					+	GAS	211029	SG0824			516010
520i excl. ,	(E34)	01.88 - 07.90		9C		GAS	210014	CG0825			516004
					+	GAS	211029	SG0824			516010

BMW (D)

520i excl. ʘ, ʘ, ʘ	(E34)	08.90 - 09.95		9B	/	GAS	210020	CG0833			516004
					/	GAS	211029	SG0824			516010
520i ʘ excl. ʘ, ʘ	(E34)	08.90 - 08.92		9D	/	GAS	210015	CG0826			516004
					/	GAS	211029	SG0824			516010
520i ʘ excl. ʘ, ʘ	(E34)	09.92 - 09.95		9B	/	GAS	210020	CG0833			516004
					/	GAS	211029	SG0824			516010
525i excl. ʘ, ʘ	(E34)	01.88 - 07.90		9C	/	GAS	210014	CG0825			516004
					/	GAS	211029	SG0824			516010
525i excl. ʘ, ʘ	(E34)	08.90 - 08.92		9D	/	GAS	210015	CG0826			516004
					/	GAS	211029	SG0824			516010
525i excl. ʘ, ʘ	(E34)	09.92 - 09.95		9B	/	GAS	210020	CG0833			516004
					/	GAS	211029	SG0824			516010
525iX excl. ʘ, ʘ	(E34)	05.91 - 09.95			/						516004
					/	GAS	211029	SG0824			516010
530i excl. ʘ, ʘ	(E34)	01.88 - 07.90		9C	/	GAS	210014	CG0825			516004
					/	GAS	211029	SG0824			516010
530i excl. ʘ, ʘ	(E34)	08.90 - 09.95		9D	/	GAS	210015	CG0826			516004
					/	GAS	211029	SG0824			516010
535i excl. ʘ, ʘ	(E34)	01.88 - 07.90		9C	/	GAS	210014	CG0825			516004
					/	GAS	211029	SG0824			516010
535i, 540i excl. ʘ, ʘ	(E34)	08.90 - 09.95		9D	/	GAS	210015	CG0826			516004
					/	GAS	211029	SG0824			516010
524 TD excl. ʘ, ʘ	(E34)	01.88 - 07.90		9C	/	GAS	210014	CG0825			516004
					/	GAS	211029	SG0824			516010
524 TD excl. ʘ, ʘ	(E34)	08.90 - 08.92		9D	/	GAS	210015	CG0826			516004
					/	GAS	211029	SG0824			516010
525 TD, 525 TDS excl. ʘ, ʘ	(E34)	08.90 - 08.92		9D	/	GAS	210015	CG0826			516004
					/	GAS	211029	SG0824			516010
525 TD, 525 TDS excl. ʘ, ʘ	(E34)	09.92 - 09.95		9B	/	GAS	210020	CG0833			516004
					/	GAS	211029	SG0824			516010
Touring 518i, 520i excl. ʘ, ʘ, ʘ	(E34)	08.91 - 01.97		9B	/	GAS	210020	CG0833			516004
					/	GAS	211029	SG0824			516010
Touring 518i, 520i ʘ excl. ʘ, ʘ	(E34)	08.91 - 01.97		9C	/	GAS	210015	CG0826			516004
					/	GAS	211029	SG0824			516010
Touring 525i excl. ʘ, ʘ	(E34)	08.91 - 01.97		9D	/	GAS	210015	CG0826			516004
Touring 530i, 535i, 540i excl. ʘ, ʘ	(E34)	08.91 - 01.97		9D	/	GAS	210015	CG0826			516004
Touring 524 TD excl. ʘ, ʘ, ʘ	(E34)	08.91 - 01.97		9B	/	GAS	210020	CG0833			516004
					/	GAS	211029	SG0824			516010
Touring 524 TD ʘ Touring 525 TDS excl. ʘ, ʘ	(E34)	08.91 - 01.97 08.91 - 01.97		9D	/	GAS	210015	CG0826			516004
					/	GAS	211029	SG0824			516010

5 SERIES (E39) EXCL. M-TECHNIK

520i, 523i, 525i, 525 TDS, 528i, 530D excl. ʘ	(E39)	11.95 - 06.03			/	GAS	210183	MG0841	600240	516004
					/	GAS	211032	SG0842		516010
535i, 540i excl. ʘ	(E39)	11.95 - 06.03			/	GAS	210184	MG0844	600240	516004
					/	GAS	211032	SG0842		516010
Touring 520i, 523i, 525i, 525 TDS, 528i, 530D excl. ʘ	(E39)	01.97 - 05.04			/	GAS	210183	MG0841	600240	516004
					/	GAS	211322	TG0843		516010

BMW (D)

Touring 535i, 540i excl.	(E39)	01.97 - 05.04				GAS	210184	MG0844	600240	516004
						GAS	211322	TG0843		516010

5 SERIES (E60) EXCL. M-TECHNIK

520i, 530i 530d 525i, 545i, 525d	(E60)	07.03 - 03.10				GAS	210200	MG0893	MG0894	600240	516004
		09.03 - 03.10				GAS	211035	SG0895			
535d 523i, 520d, 550i	(E60)	09.04 - 03.10				GAS	210200	MG0893	MG0894	600240	516004
		07.05 - 03.10				GAS	211035	SG0895			

5 SERIES TOURING (E61)

520i, 525i, 530i, 545i, 525d, 530d 535d	(E61)	06.04 - 12.10				GAS	210938	MG6101	MG6102	600240	516004
		09.04 - 12.10				GAS	211037	SG0899			
523i	(E61)	07.05 - 12.10				GAS	210938	MG6101	MG6102	600240	516004
						GAS	211037	SG0899			

5 SERIES (F10, F18) EXCL. M-TECHNIK

523i, 528i, 535i, 550i excl. X-Drive 520d, 525d, 530d, 535d excl. X-Drive	(F10)	01.09 - 10.16				GAS	211222	SG6113	SG6114		516004
				excl.		GAS	212061	TG6115			516010

5 SERIES TOURING (F11)

excl.	(F11)	11.09 -				GAS	211222	SG6113	SG6114		516010
						GAS	212067	TG6132			

6 SERIES (E24) EXCL. M-TECHNIK

	(E24)	04.76 - 06.78				GAS	210007	CG0803			516004
						GAS	211027	SG0820			
	(E24)	06.78 - 05.82				GAS	210016	CG0827			516004
						GAS	211027	SG0820			
excl.	(E24)	06.82 - 09.90				GAS	210012	CG0821			516004
				excl.		GAS	211028	SG0822			

6 SERIES (E63, E64) EXCL. M-TECHNIK

630i, 650i, 645Ci, 635d excl. 630i, 650i, 645Ci, 635d excl.	(E63, E64)	01.04 - 12.10				GAS	210200	MG0893	MG0894	600240	516004
		09.04 - 12.10		excl.		GAS	211224	SG6116			516010

6 SERIES TOURING (F12, F13)

640i, 650i, 640d, excl. , 4x4	(F12)	03.11 -				GAS	211222	SG6113	SG6114		
						GAS	211227	SG6133			
640i, 650i, 640d, excl. , 4x4	(F12)	10.11 -				GAS	211222	SG6113	SG6114		
						GAS	211227	SG6133			

7 SERIES (E23)

728, 728i, 730, 733i	(E23)	1977 - 09.79				GAS	210016	CG0827			516004
						GAS	211025	SG0804			
728i, 732i, 735i 745i	(E23)	09.79 - 09.81				GAS	210016	CG0827			516004
		07.79 - 08.86									
728i, 732i, 735i	(E23)	10.81 - 08.86				GAS	210016	CG0827			516004
						GAS	211030	SG0828			

BMW (D)

7 SERIES (E32) EXCL. M-TECHNIK

730i, 735i, 735iL excl. ,	(E32)	09.86 - 02.88			/	GAS	210017	CG0830			516004
				excl.	/	GAS	211031	SG0829			
730i, 735i, 735iL excl. ,	(E32)	03.88 - 07.90			/	GAS	210018	CG0831			516004
				excl.	/	GAS	211031	SG0829			
730i, 735i, 735iL excl.	(E32)	08.90 - 07.94			/	GAS	210019	CG0832			516004
				excl.	/	GAS	211031	SG0829			

7 SERIES (E38) EXCL. M-TECHNIK

725tds, 728i, 730i, 740i 728iL, 730iL, 740iL, 750iL	(E38)	05.94 - 11.01			/	GAS	210940	MG6107	MG6106			516004
		05.94 - 11.01		excl.	/	GAS	211219	SG6108				

7 SERIES (E65, E66) EXCL. M-TECHNIK

730i, 735i, 740i, 745i, 750i, 760i incl. Li excl. 730d, 730Ld excl.	(E65, E66)	11.01 - 12.09			/	GAS	210942	MG6117	MG6118			516004
				excl.	/	GAS	211225	SG6119				

7 SERIES (F01, F02, F03, F04) EXCL. M-TECHNIK

730i, 740i, 750i, excl. , xDrive, Active Hybrid 760i, 730d, 740d excl. , xDrive, Active Hybrid	(F01, F02, F03, F04)	06.08 - 12.15			/							516004
				excl.	/							

8 SERIES (E31) EXCL. M-TECHNIK

excl. ,	(E31)	04.90 - 12.99			/							516004
					∅							

(E3)

		10.68 - 04.77			/	GAS	210007	CG0803				516004
					∅							

(E9)

2.5 CS, 3.0 CS 3.0 CSi		01.74 - 12.76			/	GAS	210007	CG0803				516004
		04.71 - 12.75			∅							

X1 (E84)

xDrive	(E84)	10.09 - 06.15			/	GAS	210944	MG6123	MG6122	600240		516004
				excl.	+	GAS	212062	TG6124				
sDrive	(E84)	10.09 - 06.15			/	GAS	210943	MG6121	MG6120	600240		516004
				excl.	+	GAS	212062	TG6124				

X1 (F48)

excl. X-Drive, ,	(F48)	11.14 -			/	GAS	210949	MG6143	MG6142			516004
					∅	GAS	212069	TG6144				

X3 (E83)

2.5i, 3.0i, 3.0d 2.0d	(E83)	01.04 - 12.11			/	GAS	210194	MG0873	MG0874	600240		516004
		10.04 - 12.11			∅	GAS	211326	TG0872				

X3 (F25)

excl. X-Drive, ,	(F25)	09.10 -			/	GAS	210947	MG6135	MG6134			516004
					/	GAS	211228	SG6136				

BMW (D)

X4 (F26)

excl. X-Drive, ,	(F26)	04.14 - 03.18				GAS	210947	MG6135	MG6134			516004
						GAS	211228	SG6136				

X5 (E53)

3.0i, 4.4i, 3.0d, 4.6is excl.	(E53)	05.00 - 12.06				GAS	210195	MG0875	MG0876			516004
						GAS	211327	TG0877				516001

X5 II (E70)

3.0 si, 3.0 d, 3.0 sd incl. xDrive, excl. M, ,	(E70)	02.06 - 07.13				GAS	211226	SG6127				516010
						GAS	212063	TG6125	TG6126			

X6 (E71, E72)

35i, 50i, 30d, 35d incl. xDrive, excl. M, , , Active Hybrid	(E71, E72)	05.08 - 06.14				GAS	211226	SG6127				
						GAS	212063	TG6125	TG6126			

Z3 (E36)

1.8, 1.9, 2.0, 2.2, 2.8, 3.0 2.8, 3.0 excl.	(E36)	10.95 - 06.03				GAS	210181	MG0815	MG0816			516004
						GAS	211321	TG0840				

Z4 (E85)

2.5i, 3.0i, 2.2i, 2.0i	(E85)	02.03 - 12.09				GAS	210196	MG0879	MG0880			516004
						GAS	211328	TG0878				

CHEVROLET (EU)

AVEO

	(T250, T255)	05.05 -				GAS	210931	MG5917	MG5918			516004
						GAS	212051	TG5919				516010
	(T300)	03.11 -										
						GAS	211704	TG2989		600781	600782	516010

CAPTIVA

	(C100, C140)	06.06 -				GAS	210869	MG5205	MG5206	600170		516004
						GAS	211706	TG2998				

CRUZE

	(J300, J305, J308)	05.09 -				GAS	210871	MG5211	MG5210			516004
		06.11 -				GAS	212003	TG5212				516010

KALOS

		03.05 -				GAS	210931	MG5917	MG5918			516004
						GAS	212051	TG5919				516010

LACETTI

	(J200)	03.05 -				GAS	210934	MG5927	MG5928			516004
						GAS	210935	MG5929	MG5930			516004

MATIZ

	(M220, M250)	03.05 -				GAS	210932	MG5921	MG5922			516004
						GAS	212052	TG5920				

ORLANDO

	incl. 16, 17 e 18 inch	(J309)	02.11 -				GAS	210871	MG5211	MG5210			516004
							GAS	212055	TG5934				516010

NUBIRA

		03.05 - 12.09				GAS	210934	MG5927	MG5928			516004
						GAS	210935	MG5929	MG5930			516004

SPARK

		05.05 -				GAS	210932	MG5921	MG5922			516004
						GAS	212052	TG5920				516010
	(M300)	03.11 -										516004
						GAS	212056	TG5935				516010

TACUMA

		03.05 -				GAS	210936	MG5931	MG5932			516004
						GAS	212054	TG5933				

CHRYSLER (USA)

300 C

	(LX)	09.04 - 11.12				GAS	211044	SG1027	SG1028			
			09.04 - 12.10						GAS	211364	HG1029	

GRAND VOYAGER

excl.	(RT)	10.07 -				GAS	210450	MG2248			516004
								GAS	211505	TG2249	

NEON

excl.	(PL)	10.93 - 08.99				GAS	210230	MG1003			516004
								GAS	210231	MG1004	
		08.99 - 12.06				GAS	210236	MG1024			516004
								GAS	210237	MG1025	MG1026

PT CRUISER

excl.		06.00 - 12.10				GAS	210234	MG1009			516004
								GAS	211363	TG1010	

STRATUS/CIRRUS

	(JA)	12.95 - 04.01				GAS	210233	MG1007			516004
								GAS	211043	SG1008	
	(JX)	04.96 - 04.01				GAS	210233	MG1007			516004
								GAS	211043	SG1008	

VOYAGER I / II

	(AS)	08.84 - 12.85									516004
								GAS	211362	HG1002	
4X2, 4X4 incl. Grand Voyager, Grand Caravan	(ES)	01.86 - 01.95				GAS	210229	MG1001			516004
								GAS	211362	HG1002	

VOYAGER III

excl. 4X4, incl. Grand Voyager, Grand Caravan	(GS)	02.95 - 03.01		10A		GAS	210232	MG1005			516004
								GAS	211362	HG1002	

VOYAGER IV

excl. 4X4 incl. Grand Voyager, Grand Caravan	(RG)	02.00 - 12.08		10B		GAS	210235	MG1023	600250		516004
								GAS	211362	HG1002	

CITROËN (F)

2 CV

2 CV, 2 CV 4, 2 CV 6 AK 250		01.65 - 07.90			⊗	OIL	201335	T 0901			
		01.65 - 07.90			⊗	OIL	201336	T 0902			
AK 400, AK 350		01.63 - 06.76			⊗	OIL	201335	T 0901			
					⊗						
AKS 400		07.76 -			⊗						
					⊗						

ACADIANE

		08.78 - 10.83			⊗						
					⊗						

AMI

Ami 6		01.61 - 05.63			⊗	OIL	201335	T 0901			
					⊗	OIL	201336	T 0902			
Ami 6 Ami 8 excl. Super		06.63 - 07.69 07.69 - 12.77			⊗	OIL	201335	T 0901			
					⊗						
Ami 8 Super		1973 -			⊗						
					⊗						

AX

1.0, 1.1	(ZA)	07.86 - 12.98			/	OIL	200022	C 0907	600120	516004
					/	GAS	210022	CG0907		
					⊗	OIL	201340	T 0908		
					⊗	GAS	211340	TG0908		
1.3 Sport	(ZA)	04.87 - 12.88			/	OIL	200022	C 0907	600120	516004
					/	GAS	210022	CG0907		
					⊗	OIL	201340	T 0908		
					⊗	GAS	211340	TG0908		
1.4 excl. Gti, 4X4 1.4 D, 1.5 D excl. 4X4	(ZA)	07.86 - 12.98 09.88 - 12.98			/	OIL	200022	C 0907	600120	516004
					/	GAS	210022	CG0907		
					⊗	OIL	201340	T 0908		
					⊗	GAS	211340	TG0908		
1.4 Gti 1.4 4X4	(ZA)	05.91 - 12.96 08.91 - 12.96			/	GAS	210022	CG0907	600120	516004
					⊗	GAS	211340	TG0908		

AXEL/OLTCIT

		10.81 - 03.91			⊕	OIL	201341	T 0909			516004
					⊗	OIL	201342	T 0910			

BERLINGO

excl. 4X4	(MF)	07.96 - 11.02			⚡	GAS	210210	MG0949	MG0948	600110	516004	
					⊗	GAS	211713	TG3027				
excl. 4X4	(G)	12.02 -			⚡	GAS	210588	MG3067	MG3066	600101	600102	516004
					⊗	GAS	211713	TG3027				
		04.08 -			⚡	GAS	210224	MG0985	MG0984	600090	516004	
					⊗	GAS	211357	TG0986				

CITROËN (F)

C1

1.0i, 1.4d	(PM, PN)	07.05 - 09.14				GAS	210223	MG0981	MG0982			516003
						GAS	211356	TG0983				516010

C1 II

1.0 Vti, 1.2 Vti		04.14 -				GAS	210223	MG0981	MG0982			516004
						GAS	211356	TG0983				516010

C2

1.1, 1.4 excl.	(JM)	09.03 -				GAS	210221	MG0975	MG0974			516004
						GAS	211353	TG0956				
1.4 Hdi excl.	(JM)	09.03 -				GAS	210212	MG0955	MG0954	600230		516004
						GAS	211353	TG0956				
1.6 16V	(JM)	09.03 -				GAS	210212	MG0955	MG0954	600230		516004
						GAS	211353	TG0956				

C3

1.1, 1.4 excl.	(FC)	04.02 -				GAS	210212	MG0955	MG0954	600230		516004
						GAS	211353	TG0956				
1.6, 1.4 Hdi excl.	(FC)	04.02 -				GAS	210212	MG0955	MG0954	600230		516004
						GAS	211353	TG0956				
	(FC)	04.02 -				GAS	210212	MG0955	MG0954	600230		516004
						GAS	211353	TG0956				
Pluriel	(HB)	05.03 -				GAS	210221	MG0975	MG0974			516004
						GAS	211353	TG0956				

C3 II

	(SC_)	11.09 -		11A		GAS	210226	MG0991	MG0990	600235		516004
						GAS	211359	TG0992				
	(SC_)	11.09 -		11B		GAS	210227	MG0993	MG0994	600235		516004
						GAS	211359	TG0992				

C3 III

	(SX)	07.16 -		11B		GAS	212139	MG6609	MG6610			
						GAS	212141	TG6613				
	(SX)	07.16 -		11A		GAS	212140	MG6611	MG6612			
						GAS	212141	TG6613				

C3 PICASSO

		02.09 -				GAS	210593	MG3079	MG3080			516004
						GAS	211732	TG3081				

C4

excl. 2.0 Hdi (136 HP), 2.0 16V (177 HP)	(LC)	11.04 - 07.11				GAS	210589	MG3069	MG3070	600090		516004
						GAS	211729	TG3068				
2.0 Hdi (136 HP), 2.0 16V (177 HP)	(LC)	11.04 - 07.11				GAS	210589	MG3069	MG3070	600090		516004
						GAS	211355	TG0980				

CITROËN (F)

C4 II

	(B7)	11.09 -				GAS	210228	MG0995	MG0996			516004
						GAS	211360	TG0997				

C4 AIRCROSS

		04.12 -				GAS	210538	MG2691	MG2692			516004
						GAS	211121	SG2693				516010

C4 CACTUS

		09.14 -		11B		GAS	210227	MG0993	MG0994	600235		516004
						GAS	211361	TG0998				
		09.14 -		11A		GAS	210226	MG0991	MG0990	600235		516004
						GAS	211361	TG0998				

C4 PICASSO/GRAND PICASSO

	(UD)	02.07 - 08.13				GAS	210224	MG0985	MG0984	600090		516004
	(UA)		10.06 -				GAS	211357	TG0986			

C4 PICASSO II/GRAND PICASSO II

		02.13 -				GAS	210603	MG3115				516004
						GAS	211740	TG3114				516010

C5

	(RD, TD)	02.08 -				GAS	211138	SG3082				
						GAS	211139	SG3083				

C8

	(EA, EB)	06.02 -				GAS	210447	MG2241	MG2242	600741	600742	516004
						GAS	211289	TG0636				

C15

	(VD)	10.84 - 05.88				OIL	200202	M 0914				516004
						OIL	201042	S 0919				
	(VD)	05.88 -				OIL	200203	M 0918				516004
						OIL	201042	S 0919				
	(VD)	07.87 - 06.88				OIL	200203	M 0918				516004
						OIL	201042	S 0919				
	(VD)	07.86 -										
	(VD)	07.86 -				OIL	200203	M 0918				516004
						OIL	201042	S 0919				

C25

	(280, 290)	07.81 - 12.85				OIL	200206	M 0932				516004
				14A		OIL	201347	H 0934				
	(280, 290)	07.81 - 12.85				OIL	200206	M 0932				516004
				14B		OIL	201348	H 0935				
	(280, 290)	01.86 - 03.94				OIL	200207	M 0933				516004
				14A		OIL	201347	H 0934				

CITROËN (F)

1800 Kg	(280, 290)	01.86 - 03.94		14C		OIL	200136	M 0601			516004
						OIL	201278	H 0602			
	(280, 290)	01.86 - 03.94		14B		OIL	200207	M 0933			516004
						OIL	201348	H 0935			

C32, C35

		11.73 - 01.94				OIL	201345	T 0930			
						OIL	201346	H 0931			

C-CROSSER

2.4, 2.2 Hdi	(EP)	02.07 -				GAS	210225	MG0987	MG0988			516004
						GAS	211358	TG0989				

C-ELYSEE

		11.12 -				GAS	210973	MG6601	MG6602			516004
						GAS	212090	TG6603				

DYANE

excl. Acadyane		08.67 - 10.84				OIL	201335	T 0901			
						OIL	201336	T 0902			

DS3

		11.09 - 07.15		11A		GAS	210226	MG0991	MG0990	600235	516004
						GAS	211359	TG0992			
		11.09 - 07.15		11B		GAS	210227	MG0993	MG0994	600235	516004
						GAS	211359	TG0992			

DS4

		04.11 - 07.15				GAS	210228	MG0995	MG0996			516004
						GAS	211360	TG0997			516010	

DS5

		11.11 - 07.15				GAS	210974	MG6605	MG6604			516004
						GAS	211357	TG0986				

EVASION/SYNERGIE

(> Ch. 7609)	(22, U6)	03.94 - 12.97		18B		GAS	210270	MG1366		600741	600742	516004
						GAS	211401	TG1367				

JUMPER/RELAY

1000 Kg, 1400 Kg	(230L)	02.94 - 04.02		15B		OIL	200265	M 1355		600071	600072	516007
						GAS	210265	MG1355				
				14C		OIL	201398	H 1356				
						GAS	211398	HG1356				
1800 Kg	(230L)	02.94 - 04.02		15B		OIL	200280	M 1385		600071	600072	516007
						GAS	210280	MG1385				
				14E		OIL	201405	H 1383				
						GAS	211405	HG1383				

CITROËN (F)

	(230P)	02.94 - 04.02		15B		OIL	200265	M 1355	600071	600072	516007
						GAS	210265	MG1355			
1000 Kg, 1400 Kg	(244)	04.02 -		15B		OIL	200265	M 1355	600071	600072	516007
						GAS	210265	MG1355			
				14C		OIL	201398	H 1356			
						GAS	211398	HG1356			
1800 Kg	(244)	04.02 -		15B		OIL	200280	M 1385	600071	600072	516007
						GAS	210280	MG1385			
				14E		OIL	201405	H 1383			
						GAS	211405	HG1383			
1000Kg 1400Kg	(250)	04.06 -		15C		GAS	210881	MG5309	600651	600652	516007
				14F		GAS	211296	HG0655			
1400Kg 2000Kg	(250)	04.06 -		15C		GAS	210882	MG5310	600651	600652	516007
				14G		GAS	211301	HG0672			
1000Kg 1400Kg REINFORCED	(250)	04.06 -		15C		GAS	210159	MG0654	600651	600652	516007
				14F		GAS	211296	HG0655			
1400Kg 2000Kg REINFORCED	(250)	04.06 -		15C		GAS	210167	MG0670	600651	600652	516007
				14G		GAS	211301	HG0672			

JUMPY/DISPATCH

(> Ch. 7609)	(U6U)	06.94 - 09.97				GAS	210270	MG1366	600741	600742	516004	
				18A		GAS	211401	TG1367				
(Ch. 7610 > 9793)	(U6U)	09.97 - 10.03				GAS	210270	MG1366	600741	600742	516004	
				18B		GAS	211351	TG0944				
(Ch. 9794 > 10408)		10.03 - 05.04				GAS	210166	MG0669	MG0668	600741	600742	516004
				18B		GAS	211351	TG0944				
(Ch. 10409 >)		05.04 -				GAS	210270	MG1366	600741	600742	516004	
				18B		GAS	211351	TG0944				
1.6D, 2.0 D	(272)	01.07 -				GAS	210169	MG0677	MG0676	600741	600742	516004
				18C		GAS	211303	TG0678				
1.6D, 2.0 D H.D.	(272)	01.07 -				GAS	210170	MG0679	MG0680	600741	600742	516004
				18D		GAS	211304	TG0681				

LN/LNA

LN 0.6		04.77				OIL	200023	C 0911			516004
						OIL	201038	S 0912			
LN 0.6		05.77 - 12.80				OIL	200023	C 0911			516004
						OIL	201039	S 0913			
LNA 0.6, 1.1		11.78 - 10.86				OIL	200202	M 0914			516004
						OIL	201039	S 0913			

MEHARI

excl. 4X4, F.A.F.		05.68 - 10.87				OIL	201335	T 0901			
						OIL	201336	T 0902			
4X4, F.A.F.		10.79 - 10.87									

CITROËN (F)

NEMO

1.2 HDi, 1.4, 1.4 HDi N.D. Finestrato	(AA)	02.08 -			GAS	210173	MG0685	MG0684	600541	600542	516004
					GAS	211305	HG0686				
1.2 HDi, 1.4, 1.4 HDi H.D. Cassonato	(AA)	02.08 -			GAS	210173	MG0685	MG0684	600541	600542	516004
					GAS	212012	HG5314				

SAXO

1.0, 1.1	(S0, S1)	05.96 - 04.04			OIL	200022	C 0907		600120		516004
					GAS	210022	CG0907				
					OIL	201340	T 0908				
					GAS	211340	TG0908				
1.4 1.5 D	(S0, S1)	05.96 - 04.04 05.96 - 04.04			OIL	200022	C 0907		600120		516004
					GAS	210022	CG0907				
					OIL	201340	T 0908				
					GAS	211340	TG0908				
1.6, 1.6 16V	(S0, S1)	05.96 - 04.04			OIL	200022	C 0907		600120		516004
					GAS	210022	CG0907				
					OIL	201340	T 0908				
					GAS	211340	TG0908				

VISA

excl. Chrono, GT, GTI, 1.7 D		09.78 - 03.91			OIL	200202	M 0914				516004
					OIL	201040	S 0915				
Chrono, GT, GT Tonic		09.78 - 03.91			OIL	200202	M 0914				516004
					OIL	201041	S 0916				
1.6 GTI		01.85 - 03.91									516004
					OIL	201041	S 0916				
1.7 D		06.84 - 03.91			OIL	200575	M 3009				516004
					OIL	201040	S 0915				

XSARA

1.1, 1.4, 1.6, 1.8 excl. VTS 1.9 D, 1.9 TD, 2.0 Hdi excl. VTS	(N1, N0)	04.97 - 09.00			GAS	210210	MG0949	MG0948	600110		516004
					OIL	201344	T 0929				
		04.97 - 09.00			GAS	211709	TG3020				
					GAS	211708	TG3008				
VTS	(N0)	02.98 - 09.00			GAS	210210	MG0949	MG0948	600110		516004
					GAS	211708	TG3008				
1.4 excl.	(N1, N0)	09.00 - 04.05			GAS	210215	MG0961	MG0962	600110		516004
					OIL	201344	T 0929				
					GAS	211709	TG3020				
					GAS	211708	TG3008				
1.6, 2.0, 2.0 VTS, 1.9 D, 2.0 Hdi excl.	(N1, N0)	09.00 - 04.05			GAS	210217	MG0965	MG0966	600110		516004
					OIL	201344	T 0929				
		09.00 - 04.05			GAS	211709	TG3020				
					GAS	211708	TG3008				
	(N2)	10.97 - 09.00			GAS	210210	MG0949	MG0948	600110		516004
					GAS	211708	TG3008				

CITROËN (F)

1.4 excl.	(N2)	09.00 - 08.05 09.00 - 08.05				GAS	210215	MG0961	MG0962	600110	516004
				N.D.		OIL	201344	T 0929			
				N.D.		GAS	211709	TG3020			
				H.D.		GAS	211708	TG3008			
1.6, 2.0, 2.0 VTS, 1.9 D, 2.0 Hdi excl.	(N2)	09.00 - 08.05				GAS	210217	MG0965	MG0966	600110	516004
				N.D.		OIL	201344	T 0929			
				N.D.		GAS	211709	TG3020			
				H.D.		GAS	211708	TG3008			
	(N1, NO, N2)	09.00 - 08.05 09.00 - 08.05				GAS	210216	MG0963	MG0964		516004
						GAS	211350	TG0942			

XSARA PICASSO

	(N68)	12.99 -				GAS	210209	MG0945	MG0946	600110	516004
						GAS	211352	TG0947			

ZX

1.1 1.4	(N2)	03.91 - 06.97 03.91 - 06.97				GAS	212091	MG0953	MG0952	600110	516004
						OIL	201344	T 0929			
						GAS	211709	TG3020			
1.6, 1.8 1.8 D, 1.9 D, 1.9 TD excl. Volcane	(N2)	03.91 - 06.97 03.91 - 06.97				GAS	210210	MG0949	MG0948	600110	516004
				N.D.		OIL	201344	T 0929			
				N.D.		GAS	211709	TG3020			
1.9, 2.0 > Ch. 5683	(N2)	03.91 - 03.92 03.91 - 03.92				GAS	210205	MG0923	MG0924	600110	516004
						GAS	211708	TG3008			
1.9, 2.0 Volcane Ch. 5684 > 2.0 16V	(N2)	06.91 - 06.97				GAS	210210	MG0949	MG0948	600110	516004
						GAS	211708	TG3008			
	(N2)	10.93 - 10.97				GAS	210210	MG0949	MG0948	600110	516004
						GAS	211349	TG0936			

DACIA (R)

1000 SERIES

1210, 1300, 1310, 1410		12.72 - 05.83				OIL	201143	S 3322			
						OIL	201756	T 3323			

DOKKER

		11.12 -				GAS	210960	MG6217			516004
						GAS	212077	TG6218			

DUSTER

1.5 dCi, 1.6 16V excl 4x4		04.10 -				GAS	210956	MG6212			516004
						GAS	212075	TG6211			516011
1.5 dCi, 1.6 16V incl 4x4		06.10 -				GAS	210956	MG6212			516004
						GAS	210957	MG6213			516004

LODGY

		03.12 -				GAS	210961	MG6219			516004
						GAS	212078	TG6220			

LOGAN

1.4, 1.5 dCi, 1.6 16V	(LS)	09.04 -				GAS	210951	MG6201			516004
						GAS	212070	TG6202			516011
MCV 1.4, 1.6 16v, 1.5 dCi	(KS)	02.07 -				GAS	210952	MG6203			516004
						GAS	212071	TG6204			516011
Express	(FS)	03.09 -				GAS	210953	MG6205			516004
						GAS	212072	TG6206			516011
Pick-up	(US)	03.08 -				GAS	210954	MG6207			516004
						GAS	212073	TG6208			516011

LOGAN II

		10.12 -				GAS	210958	MG6214			516004
						GAS	212076	TG6215			516011
MCV		02.13 -				GAS	210958	MG6214			516004

SANDERO

		06.08 -				GAS	210955	MG6209			516004
						GAS	212074	TG6210			516010

SANDERO II

		10.12 -				GAS	210959	MG6216			516004
						GAS	212076	TG6215			516011

DAEWOO (KO) CHEVROLET (EU)
ESPERO

	(KLEJ)	10.91 - 09.99			/	GAS	210046	CG2927			516004
					o	OIL	201662	T 2905			516010

KALOS

	(KLAS)	09.02 -			o	GAS	210931	MG5917	MG5918			516004
					o	GAS	212051	TG5919				516010

LACETTI

	(KLAN)	02.04 -			o	GAS	210934	MG5927	MG5928			516004
					o	GAS	210935	MG5929	MG5930			516004

LANOS

	(KLAT)	05.97 -			/	GAS	210046	CG2927			516004
					o	GAS	201662	T 2905			516010

LEGANZA

	(KLAV)	06.97 - 04.04			o	GAS	210929	MG5913	MG5914			
					o	GAS	210930	MG5915	MG5916			

MATIZ

incl. ABS	(KLYA)	09.98 -			o	OIL	200924	M 5901	M 5902	600140	516004
					o	GAS	210924	MG5901	MG5902		
					o	OIL	202049	T 5903			
					o	GAS	212049	TG5903			
		03.05 - 06.10			o	GAS	210932	MG5921	MG5922		516004
					o	GAS	212052	TG5920			

NEXIA/CIELO

	(KLETN)	01.95 - 08.97			/	GAS	210046	CG2927			516004
					o	GAS	201662	T 2905			516010

NUBIRA

incl. ABS	(KLAJ)	05.97 - 07.97			o	GAS	210926	MG5907	MG5908			516004
					o	GAS	210927	MG5909	MG5910			516004
incl. ABS	(KLAJ)	08.97 - 05.99			o	GAS	210928	MG5911	MG5912			516004
					o	GAS	210927	MG5909	MG5910			516004
incl. ABS	(KLAJ)	06.99 - 07.03			o	GAS	210928	MG5911	MG5912			516004
					o	GAS	210927	MG5909	MG5910			516004
	(KLAN)	07.03 - 12.09			o	GAS	210934	MG5927	MG5928			516004
					o	GAS	210935	MG5929	MG5930			516004

TACUMA/REZZO

incl. ABS	(KLAU)	09.00 -			o	GAS	210933	MG5923	MG5924			516004
					o	GAS	212053	TG5925				

TICO

	(KLY3)	02.95 - 12.00			o	GAS	210925	MG5905	MG5904			516004
					o	GAS	212050	TG5906				

DAIHATSU (J)

FEROZA/SPORTRAK 4X4

F 300 series excl. F310, 4x4	(F300)	10.88 - 12.97			⊖	GAS	211365	HG1208			
					⊖	GAS	211366	HG1209			
F 310 serie excl. 4x4	(F310)	05.92 - 12.97			⊖	GAS	211365	HG1208			
					+						

FOURTRAK/ROCKY/TAFT 4X4

	(F10, F20, F50, F60)	1974 - 1984			∞	GAS	211367	HG1210			
					∞	OIL	201368	H 1211			
	(F25, F55, F65)	1979 - 1984			∞	GAS	211367	HG1210			
					♀	OIL	201634	T 2836			
	(F70, F75, F80, F85)	1984 - 04.93			⊖	GAS	211366	HG1209			
					⊖	GAS	211366	HG1209			
	(F77, F87)	1984 - 04.93			⊖	GAS	211366	HG1209			
					♀	OIL	201634	T 2836			
	(F73, F78, F98)	05.93 -			⊖	GAS	211369	HG1213			
					⊖	GAS	211370	HG1214			

TERIOS

	(J1)	10.97 - 05.00			4x4	GAS	210238	MG1215	MG1216			516004
					∞	GAS	211371	TG1217				
	(J1)	05.00 - 10.05			4x4	GAS	210238	MG1215	MG1216			516004
					∞							

TERIOS II

	(J2)	05.06 - 10.08			4x4	GAS	210239	MG1264				
					∞	GAS	211374	TG1265				

WIDE CAB

	850-1000	(S65V)	04.81 - 11.83			4x4	OIL	201312	T 0703				
						∞	GAS	211312	TG0703				
	(S70, S75)	01.83 -				4x4	OIL	201312	T 0703				
						∞	GAS	211367	HG1210				
	4X4	(S76)	05.84 -			4x4							
						∞	GAS	211367	HG1210				

DR (I)

CITYCROSS

1.3, 1.3 GPL, 1.3 METANO		01.14-			GAS	210967	MG6401			516004
					GAS	212085	TG6406			516010

DR 0

1.0		01.15-			GAS	210967	MG6401			516004
					GAS	212083	TG6402			

DR 1

1.1, 1.3		03.10-			GAS	210967	MG6401			516004
					GAS	212083	TG6402			

DR 2

1.3		09.10-			GAS	210967	MG6401			516004
					GAS	212083	TG6402			

DR 5

1.6, 1.8, 2.0, 1.9D		01.11-			GAS	210968	MG6403	MG6404		516004
					GAS	212084	TG6405			

FIAT (I)

124

S, T	(124)	02.66 - 03.75			⊖	OIL	201375	T 1301			
					⊖	OIL	201376	T 1302			
Familiare	(124)	04.67 - 03.75			⊖	OIL	201375	T 1301			
					∞	OIL	201377	T 1303			
Abarth					⊖	GAS	211297	TG0656			
					∞	GAS	210160	MG0657			

124 SPIDER II

excl.	(348)	03.16 -			∞	GAS	211208	SG5339			
					∞	GAS	211209	SG5340			
	(348)	03.16 -			∞						
					∞						

125

1.6, 1.6 Special	(125)	07.67 - 03.74			⊖	OIL	201378	T 1304			516004
					⊖	OIL	201379	T 1305			516010

126

excl. 126 Bis	(126)	09.72 - 08.87			+	OIL	201380	T 1306			
					+	OIL	201381	T 1307			
Bis	(126)	07.87 - 09.00			+	OIL	201380	T 1306			
					⊖	OIL	201400	T 1364			

127

0.9, 1.0 excl. Panorama e Diesel	(127)	06.71 - 12.86			∞	OIL	200240	M 1308			516004
					∞	OIL	200134	M 0504			516004
1.1 Sport, 1.3 Sport	(127)	07.78 - 05.83			∞	OIL	200240	M 1308			516004
					∞	OIL	200242	M 1310			516004
Panorama	(127)	01.77 - 12.86			∞	OIL	200241	M 1309			516004
					∞	OIL	200242	M 1310			516004
Diesel	(127)	01.82 - 12.84			∞	OIL	200241	M 1309			516004
					∞	OIL	200242	M 1310			516004

128

incl. Familiare e coupé 3P	(128)	03.69 - 12.84			∞	OIL	200243	M 1311			516004
					∞	OIL	200244	M 1312			516004

131

excl. Diesel > Ch. 4214186	(131)	10.74 - 02.78		12A	∞	OIL	200245	M 1313			516004
			S		⊖	OIL	201376	T 1302			
excl. Diesel Ch. 4214186 >	(131)	03.78 - 02.81		12B	∞	OIL	200246	M 1314			516004
			Racing		⊖	OIL	201376	T 1302			
excl. Diesel	(131)	03.81 - 12.83		12C	∞	OIL	200247	M 1315			516004
					⊖	OIL	201376	T 1302			
Diesel > Ch. 1012810	(131)	03.78 - 09.79		12D	∞	OIL	200248	M 1316			516004
					⊖	OIL	201376	T 1302			
Diesel Ch. 1012811 >	(131)	10.79 - 05.84		12E	∞	OIL	200249	M 1317			516004
					⊖	OIL	201376	T 1302			
excl. Diesel > Ch. 4214186	(131)	10.74 - 02.78		12A	∞	OIL	200245	M 1313			516004
					∞	OIL	201383	T 1319			

FIAT (I)

excl. Diesel Ch. 4214186 >	(131)	03.78 - 02.81		12B		OIL	200246	M 1314			516004
						OIL	201383	T 1319			
excl. Diesel	(131)	03.81 - 12.83		12C		OIL	200247	M 1315			516004
						OIL	201383	T 1319			
Diesel	(131)	10.81 - 05.84		12E		OIL	200249	M 1317			516004
						OIL	201383	T 1319			
Abarth	(131)			12F		GAS	210161	MG0658			516004
						GAS	210162	MG0659			516004

132

	(132)	04.72 - 12.82				OIL	201378	T 1304			
						OIL	201384	T 1320			

147

(> Ch. 359244)		10.76 - 12.95				OIL	200241	M 1309			
						OIL	200134	M 0504			
(Ch. 359245 >)		10.76 - 12.95				OIL	200241	M 1309			
						OIL	200242	M 1310			

238

	(238)	09.66 - 06.82				OIL	201395	T 1346			
						OIL	201396	T 1347			

242

	(242)	10.75 - 07.82				OIL	201345	T 0930			
						OIL	201346	H 0931			

500

0.5, 0.6		01.57 - 01.76			+	OIL	201380	T 1306			
					+	OIL	201381	T 1307			

500 II

	(312)	10.07 -				GAS	210168		600130	516004
						GAS	211302	TG0675		

500 L

	(351, 352)	09.12 -				GAS	210886	MG5323	MG5322		516004
						GAS	212015	TG5324		600781	600782
Living, 7 Posti	(351, 352)	09.12 -				GAS	210886	MG5323	MG5322		516004
						GAS	212019	TG5338			516001

500 X

excl. 4WD	(334)	09.14 -		13A		GAS	210888	MG5331	MG5330	600840	516004
				13A		GAS	210889	MG5333	MG5332	600851	600852
4WD	(334)	09.14 -		13B		GAS	210890	MG5335	MG5334	600840	516004
				13B		GAS	210891	MG5337	MG5336	600851	600852

600

600, 600 D		03.55 - 02.71			+	OIL	201385	T 1321			
					+	OIL	201386	T 1322			

FIAT (I)

850

850, 850 L, 850 Special		07.64 - 12.72				OIL	201387	T 1323			
						OIL	201388	T 1324			

ARGENTA

	(132A)	05.77 - 03.87				OIL	201378	T 1304			
						OIL	201384	T 1320			

BARCETTA

	(183)	03.95 - 05.05				GAS	210272	MG1370			516004
						GAS	211403	TG1371			

BRAVA/BRAVO

1.4, 1.6 (> Ch. 4085697)	(182)	10.95 - 01.96				GAS	210258	MG1338	600690		516004
						GAS	211404	TG1375			
1.4, 1.6 (Ch. 4085697 >) 1.2, 1.9 D	(182)	01.96 - 10.01 10.95 - 10.01				GAS	210273	MG1372	600690		516004
						GAS	211404	TG1375			
1.8 1.9 TD, 1.9 JTD	(182)	10.95 - 10.01 03.96 - 10.01				GAS	210274	MG1374	600690		516004
						GAS	211404	TG1375			
2.0 20V excl. Sport Pack	(182)	10.95 - 10.01				GAS	210275	MG1376	600751	600752	516004
						GAS	211404	TG1375			

BRAVO II

excl 1.9 150CV, 2.0 D Multijet	(198)	11.06 -		13A		GAS	210163	MG0660	600560		516004
						GAS	211298	TG0662			516010
1.9 150CV, 2.0 D Multijet	(198)	04.07 -		13A		GAS	210175	MG0690	600560		516004
						GAS	211298	TG0662			516010

CAMPAGNOLA

AR-59						OIL	202013	T 5315			
						OIL	202014	T 5316			
1107						OIL	200884	M 5317			
				2 PER LATO		OIL	200885	M 5319	M 5318		

CINQUECENTO

0.7, 0.8	(170)	07.91 - 01.98				OIL	200140	M 0608	600580		516004
						GAS	210140	MG0608			
						OIL	201389	T 1326			
1.1 Sporting	(170)	10.94 - 01.98				GAS	210283	MG1398	600580		
						OIL	201389	T 1326			

COUPÈ

1.8 16V, 2.0 16V, 2.0 20V	(175)	11.93 - 08.00				GAS	210271	MG1368			516004
						GAS	211402	TG1369			
2.0 Turbo 16V, 2.0 Turbo 20V	(175)	11.93 - 08.00				GAS	210276	MG1378			516004
						GAS	211402	TG1369			

FIAT (I)

CROMA

excl. 2.0 Turbo H+	(154)	12.85 - 09.86				GAS	210251	MG1329			516004
						GAS	210250	MG1328			516004
excl. 2.0 Turbo H+	(154)	10.86 - 12.96				GAS	210251	MG1329			516004
				excl.		GAS	210106	MG0113			516004
excl. 2.0 Turbo	(154)	12.85 - 09.86				GAS	210251	MG1329			516004
						GAS	210250	MG1328			516004
excl. 2.0 Turbo	(154)	10.86 - 12.96				GAS	210251	MG1329			516004
				excl.		GAS	210106	MG0113			516004
2.0 Turbo H+	(154)	12.85 - 09.86				GAS	210251	MG1329			516004
						GAS	210250	MG1328			516004
2.0 Turbo H+	(154)	10.86 - 12.96				GAS	210251	MG1329			516004
				excl.		GAS	210106	MG0113			516004
2.0 Turbo	(154)	12.85 - 09.86				GAS	210251	MG1329			516004
						GAS	210250	MG1328			516004
2.0 Turbo	(154)	10.86 - 12.96				GAS	210251	MG1329			516004
				excl.		GAS	210106	MG0113			516004

CROMA II

excl. ,	(194)	06.05 -				GAS	210567	MG2975	MG2976	600770	516004
				excl.		GAS	211700	TG2979			
,	(194)	06.05 -				GAS	210568	MG2977	MG2978	600770	516004
				excl.		GAS	211701	TG2980			

DOBLÒ

, excl.	(119)	12.00 -				GAS	210147	MG0620	600011	600012	516004
						GAS	211284	TG0622			
CARGO excl.	(223)	12.00 -				GAS	210147	MG0620	600011	600012	516004
						GAS	211284	TG0622			

DOBLÒ II

, Furgonato	(263)	02.10 -				GAS	210176	MG0691	MG0692	600541	600542	516004
						GAS	211307	TG0693				
Combi (trasporto persone)	(152, 263)	02.10 -				GAS	210176	MG0691	MG0692	600541	600542	516004
						GAS	212016	TG5325				

DOGAN / SAHIN

(Made in Egypt)						OIL	200137	M 0604			516004
						OIL	201384	T 1320			

DUCATO

10-13Q Panorama	(280)	01.82 - 04.84 07.82 - 04.84		15A		OIL	200206	M 0932			516007
				14A		OIL	201347	H 0934			
,	(280)	07.82 - 04.84		15A		OIL	200206	M 0932			516007
				14B		OIL	201348	H 0935			
10Q 1000 Kg, 14Q 1400 Kg Panorama	(280, 290)	04.84 - 03.94		15A		OIL	200207	M 0933			516007
				14A		OIL	201347	H 0934			
Maxi 18Q 1800 Kg 4X4	(280, 290)	04.84 - 03.94		15A		OIL	200136	M 0601			516007
				14C		OIL	201278	H 0602			

FIAT (I)

excl. 4X4	(280, 290)	04.84 - 03.94		15A		OIL	200207	M 0933			516007
Express 10 - 13 - 15	(280, 290)	04.84 - 03.94		15A		OIL	200207	M 0933			516007
				14A		OIL	201347	H 0934			
				14B		OIL	201348	H 0935			
1000 Kg, 1400 Kg	(230)	01.94 - 04.02		15B		OIL	200265	M 1355	600071	600072	516007
						GAS	210265	MG1355			
				14D		OIL	201398	H 1356			
						GAS	211398	HG1356			
1800 Kg	(230)	01.94 - 04.02		15B		OIL	200280	M 1385	600071	600072	516007
						GAS	210280	MG1385			
				14E		OIL	201405	H 1383			
						GAS	211405	HG1383			
Camping Car Grand Export	(230)	01.94 - 08.95		15B		OIL	200280	M 1385	600071	600072	516007
						GAS	210280	MG1385			
Camping Car Grand Export	(230)	09.95 - 04.02		15B		OIL	200280	M 1385	600071	600072	516007
						GAS	210280	MG1385			
1000 Kg, 1400 Kg	(244)	04.02 - 05.06		15B		OIL	200265	M 1355	600071	600072	516007
						GAS	210265	MG1355			
				14D		OIL	201398	H 1356			
						GAS	211398	HG1356			
1800 Kg	(244)	04.02 - 05.06		15B		OIL	200280	M 1385	600071	600072	516007
						GAS	210280	MG1385			
				14E		OIL	201405	H 1383			
						GAS	211405	HG1383			
1000Kg 1400Kg	(250)	04.06 -		15Ca		GAS	210881	MG5309	600651	600652	516007
				14F		GAS	211296	HG0655			
1400Kg 2000Kg	(250)	04.06 -		15Ca		GAS	210882	MG5310	600651	600652	516007
				14C		GAS	211301	HG0672			
1000Kg 1400Kg REINFORCED	(250)	04.06 -		15Cb		GAS	210159	MG0654	600651	600652	516007
				14F		GAS	211296	HG0655			
1400Kg 2000Kg REINFORCED	(250)	04.06 -		15Cb		GAS	210167	MG0670	600651	600652	516007
				14G		GAS	211301	HG0672			

DUNA/CITY VAN/PENNY/PREMIO

	(146B)	01.87 - 12.91				OIL	200253	M 1331			516004
						OIL	200254	M 1332			516004
Weekend, Panorama, Van	(146B)	01.87 - 12.91				OIL	200253	M 1331			516004
						OIL	200254	M 1332			516004

FIORINO

> Ch. 7017071 (Made in Europe)	(127)	10.77 - 06.82				OIL	200240	M 1308			516004
						OIL	200134	M 0504			516004
Ch. 7017072 > (Made in Europe)	(127)	07.82 - 12.84				OIL	200240	M 1308			516004
						OIL	200242	M 1310			516004
(Made in Brazil)	(127)	07.82 - 12.87				OIL	200241	M 1309			516004
						OIL	200242	M 1310			516004

FIAT (I)

(Made in Brazil)	(127)	01.87 - 12.88			OIL	200253	M 1331			516004	
					OIL	200254	M 1332			516004	
(Made in Brazil) Ch. 8000001 > 8149536	(146, 147)	01.88 - 12.90			OIL	200253	M 1331			516004	
					OIL	200266	M 1359				
(Made in Brazil) Ch. 8149537 >	(146, 147)	01.91 - 07.93			OIL	200267	M 1360			516004	
					OIL	200266	M 1359				
(Made in Brazil)	(146, 147)	08.93 - 05.01			OIL	200267	M 1360			516004	
					OIL	201399	T 1361				
					GAS	211399	TG1361				
excl. Natural power N.D. Finestrato	(225)	02.08 -			GAS	210173	MG0685	MG0684	600541	600542	516004
					GAS	211305	HG0686				
excl. Natural power H.D. Cassonato	(225)	02.08 -			GAS	210173	MG0685	MG0684	600541	600542	516004
					GAS	212012	HG5314				

FREEMONT

excl. 4x4	(JC)	08.11 -			GAS	210880	MG5307	MG5306			516004
					GAS	211207	SG5308				
4x4	(JC)	08.11 -			GAS	212138	MG5345	MG5344			516004
					GAS	211207	SG5308				

IDEA

1.2 16V, 1.4 16V	(135)	01.04 -			GAS	210164	MG0663		600130	516004
					GAS	211290	TG0638			
1.3 JTD, 1.9 JTD	(135)	01.04 -			GAS	210153	MG0637		600130	516004
					GAS	211290	TG0638			

LINEA

	(323)	06.07 -			GAS	210156	MG0647	MG0646	600500	516004
					GAS	211294	TG0648	600781	600782	516010

MAREA

Weekend 1.2, 1.4, 1.6, 1.8	(185)	09.96 - 05.02			GAS	210281	MG1394		600690	516004
			Weekend 1.9 TD, 1.9 JTD		GAS	211404	TG1375			
Weekend 2.0	(185)	09.96 - 05.02			GAS	210282	MG1395		600690	516004
			Weekend 2.4 TD, 2.4 JTD		GAS	211409	TG1399			

MULTIPLA

excl. Bipower, blupower	(186)	04.99 - 06.10			GAS	210139	MG0606		600510	516004
					GAS	211404	TG1375			
Bipower, blupower	(186)	04.99 - 06.10			GAS	210152	MG0630		600510	516004
					GAS	211404	TG1375			

PALIO/SIENA

	(178BX)	04.96 - 02.01			GAS	210006	CG0605			516004
					GAS	210138	MG0605	600011	600012	516004
					GAS	211282	TG0614			516010
Weekend	(178DX)	04.96 - 02.01			GAS	210006	CG0605			516004
					GAS	210138	MG0605	600011	600012	516004
					GAS	211404	TG1375			

FIAT (I)

		03.01 -				GAS	210172	MG0683	600011	600012	516004
							GAS	211282	TG0614		
		03.01 -				GAS	210172	MG0683	600011	600012	516004
							GAS	211404	TG1375		

PANDA I

	excl. 4X4	(141A)	03.80 - 02.86				OIL	200255	M 1333	600570	516004	
								GAS	210255		MG1333	516004
								OIL	201390		T 1334	
	excl. 4X4	(141A)	03.86 - 09.03				OIL	200255	M 1333	600570	516004	
								GAS	210255		MG1333	516004
								OIL	201274		T 0507	
								GAS	211274		TG0507	
	4X4	(141A)	09.83 - 07.04		17A		GAS	210269	MG1365	600570	516004	
								OIL	201275		T 0508	
								GAS	211275		TG0508	
	4x4 Rialzata	(141A)	09.83 - 07.04		17B		OIL	200171	M 0682		516004	
								GAS	210171		MG0682	516004
								OIL	201275		T 0508	
								GAS	211275		TG0508	

PANDA II

	excl. 4X4, easy power, natural power, van	(169)	09.03 -				GAS	210154	MG0639	MG0640	600130	516004
								GAS	211291	TG0643		
	4x4	(169)	09.03 -		17C		GAS	210155	MG0641	MG0642	600130	516004
								GAS	211292	TG0644		
	Van	(169)	09.03 -				GAS	210154	MG0639	MG0640	600130	516004
								GAS	211300	TG0667		
	1.2 Easy power (Gpl) 1.4 Easy power (Gpl)	(169)	01.07 - 09.10 -				GAS	210878	MG5303	MG5302	600130	516004
								GAS	211292	TG0644		
	1.2 Natural power (Metano) 1.4 Natural power (Metano)	(169)	01.07 - 09.10 -				GAS	210879	MG5305	MG5304	600130	516004
								GAS	212017	TG5326		
	4x4 Rialzata	(169)	09.03 -		17D		GAS	210174	MG0687	MG0688	600130	516004
							16		GAS	211306	TG0689	

PANDA III

	incl. LPG, excl. 4X4	(312)	02.12 -				GAS	210883	MG5311	MG5312		516004
								GAS	212011	TG5313		
	4X4, Natural power	(312)	06.12 -				GAS	210887	MG5327	MG5328		516004
								GAS	212018	TG5329		

PUNTO I

	1.1, 1.2, 1.6, 1.7 D 1.2, 1.6	(176) (176C)	11.93 - 09.99 04.94 - 06.00				GAS	210261	MG1349	600520	516004
								GAS	211397	TG1351	
	1.4 Turbo GT	(176)	01.94 - 09.99				GAS	210262	MG1350	600520	516004
								GAS	211397	TG1351	
	1.7 TD	(176)	01.94 - 09.99				GAS	210262	MG1350	600520	516004
								GAS	211397	TG1351	

FIAT (I)

PUNTO II

1.2, 1.2 16V, 1.4, 1.3 JTD excl.	(188)	09.99 -				GAS	210141	MG0609	600130	516004
						GAS	211280	TG0610		
1.9 D, 1.9 JTD	(188)	09.99 -				GAS	210142	MG0611	600130	516004
						GAS	211280	TG0610		
1.2 16V Sporting 1.8 16V HGT	(188)	09.99 - 09.99 -				GAS	210143	MG0612	600130	516004
						GAS	211281	TG0613		

PUNTO III (GRANDE PUNTO)

incl. Natural power	(199)	10.05 -				GAS	210156	MG0647	MG0646	600500	516004
						GAS	211294	TG0648		600781	600782

PUNTO EVO

	(199)	07.08 - 02.12				GAS	210177	MG0695	MG0694	600500	516004
						GAS	211308	TG0696			516010

QUBO

excl. Natural power N.D. Finestrato	(255)	02.08 -				GAS	210173	MG0685	MG0684	600541	600542	516004
						GAS	211305	HG0686				

REGATA

	(138)	09.83 - 12.90				OIL	200257	M 1337			516004
						OIL	200683	M 3702			
Weekend	(138)	01.84 - 06.91				OIL	200257	M 1337			516004
						OIL	200263	M 1353			

RITMO I / STRADA

excl. 125 TC	(138A, 178E)	01.78 - 10.82				OIL	200256	M 1335		600570	516004
						OIL	200683	M 3702			
125 TC	(138A, 178E)	11.81 - 10.82				GAS	210149	MG0627			516004
						OIL	200683	M 3702			
excl. Abarth	(138A, 178E)	11.82 - 12.88				OIL	200257	M 1337			516004
						OIL	200683	M 3702			
Abarth 125, 130 TC	(138A, 178E)	11.82 - 12.88				GAS	210150	MG0628			516004
						OIL	200683	M 3702			

SCUDO

(> Ch. 7609)	(220L, 220P)	02.96 - 09.97				GAS	210270	MG1366	600741	600742	516004	
				18A		GAS	211401	TG1367				
(Ch. 7610 > 9793)	(220L, 220P)	09.97 - 10.03				GAS	210270	MG1366	600741	600742	516004	
				18B		GAS	211351	TG0944				
(Ch. 9794 > 10408)		10.03 - 05.04				GAS	210166	MG0669	MG0668	600741	600742	516004
				18B		GAS	211351	TG0944				
(Ch. 10409 >)		05.04 - 02.07				GAS	210270	MG1366	600741	600742	516004	
				18B		GAS	211351	TG0944				
1.6D, 2.0 D excl H.D.	(272)	01.07 -				GAS	210169	MG0677	MG0676	600741	600742	516004
				18C		GAS	211303	TG0678				
1.6D, 2.0 D H.D.	(272)	01.07 -				GAS	210170	MG0679	MG0680	600741	600742	516004
				18D		GAS	211304	TG0681				

FIAT (I)

SEDICI

1.6 ie	(FY_)	06.06 - 10.14				GAS	210158	MG0651	MG0652			516004
								GAS	211295	TGO653		
1.9 JTD	(FY_)	06.06 - 10.14				GAS	210165	MG0665	MG0664			516004
								GAS	211299	TGO666		

SEICENTO

excl. Sporting Van	(187)	01.98 - 01.10				OIL	200140	M 0608	600580		516004
								GAS			
Sporting	(187)	01.98 - 01.10				GAS	210283	MG1398	600580		516004
								OIL	201389	T 1326	

STILO

1.2, 1.6	(192)	09.01 - 11.06		19		GAS	210144	MG0615	600560		516004
								GAS	211283	TGO618	
1.8, 1.9 JTD	(192)	09.01 - 11.06		19		GAS	210145	MG0616	600560		516004
								GAS	211283	TGO618	
2.4 20V, GT Abarth	(192)	09.01 - 11.06		19		GAS	210146	MG0617	600560		516004
								GAS	211283	TGO618	
Multiwagon 1.6	(192)	01.03 - 08.08		19		GAS	210144	MG0615	600560		516004
								GAS	211293	TGO645	
Multiwagon 1.8, 1.9 JTD	(192)	01.03 - 08.08		19		GAS	210145	MG0616	600560		516004
								GAS	211293	TGO645	
1.9 JTD 140CV 1.9D Multijet 150CV	(192)	01.04 - 09.05				GAS	210175	MG0690	600560		516004
								GAS	211283	TGO618	

STRADA

	(178E)	06.99 -				GAS	210138	MG0605	600011	600012	516004
								GAS	211399	TG1361	
1.2, 1.9 JTD	(278)	06.99 -		OE 51791061		GAS	210172	MG0683	600011	600012	516004
								GAS	211399	TG1361	
1.4, 1.6, 1.8		06.12 -				GAS	212131	MG5320			516004
								GAS	212132	TG5321	

TALENTO

	(290)	03.89 - 03.94		14A		OIL	200207	M 0933			516004
								OIL	201347	H 0934	
	(290)	03.89 - 03.94		14B		OIL	200207	M 0933			516004
								OIL	201348	H 0935	

TALENTO II

	(296)	06.16 -				GAS	212110	MG6510			516004
								GAS	212111	TG6511	

TEMPRA

1.4, 1.6, 1.9 D	(159)	03.90 - 08.97				GAS	210258	MG1338	600690		516004
								GAS	211391	TG1340	

FIAT (I)

1.8, 2.0, 1.9 TD	(159)	03.90 - 08.97				GAS	210259	MG1339	600751	600752	516004
						GAS	211391	TG1340			
SW 1.4, 1.6, 1.9 D excl. 4X4, ♀	(159)	03.90 - 08.97				GAS	210258	MG1338	600690		516004
				excl. ♀		GAS	211391	TG1340			
SW 1.8, 2.0, 1.9 TD excl. 4X4, ♀	(159)	03.90 - 08.97				GAS	210259	MG1339	600751	600752	516004
				excl. ♀		GAS	211391	TG1340			
SW ♀	(159)	03.90 - 08.97				GAS	210259	MG1339	600751	600752	516004
SW 4X4	(159)	03.90 - 08.97				GAS	210259	MG1339	600751	600752	516004
						GAS	211409	TG1399			

TIPO

1.1, 1.4, 1.6 1.7D, 1.9 D	(160)	07.87 - 04.95				GAS	210258	MG1338	600690		516004
						GAS	211391	TG1340			
1.8, 1.8 16V, 2.0, 2.0 16V 1.9 TD	(160)	07.87 - 04.95				GAS	210259	MG1339	600751	600752	516004
						GAS	211404	TG1375			

TIPO II

4 porte	(356)	10.15 -				GAS	210892	MG5341	MG5342	600500	516004
						GAS	212020	TG5343		600781	600782
5 porte	(356)	05.16 -				GAS	210892	MG5341	MG5342	600500	516004
						GAS	212020	TG5343		600781	600782
	(356)	09.16 -				GAS	210892	MG5341	MG5342	600500	516004
						GAS	212020	TG5343		600781	600782

ULYSSE I

(> Ch. 7609)	(220)	03.94 - 12.97				GAS	210270	MG1366	600741	600742	516004
				18A		GAS	211401	TG1367			
(Ch. 7610 >)	(220)	01.98 - 08.02				GAS	210270	MG1366	600741	600742	516004
				18B		GAS	211351	TG0944			

ULYSSE II

	(179AX)	08.02 - 06.11				GAS	210447	MG2241	MG2242	600741	600742	516004
						GAS	211289	TG0636				

UNO

excl. Turbo	(146A/E)	01.83 - 12.96				OIL	200260	M 1341	600640		516004
						GAS	210260	MG1341			
						OIL	201392	T 1343	600790		
						GAS	211392	TG1343			
1.3 Turbo, 1.4 Turbo	(146A/E)	01.83 - 12.96				GAS	210260	MG1341	600640		516004
						GAS	211392	TG1343	600790		

UNO (CS)









(Made in Brazil)	(CS)	01.88 - 12.91				OIL	200253	M 1331			516004
						OIL	200254	M 1332			516004

X 1/9

1,3	(128AS)	11.72 - 12.79				OIL	200277	M 1379			516004
						OIL	200278	M 1380			



FIAT (I)

1.5 Europa	(128AS)	11.78 - 12.89				OIL	200277	M 1379			516004
						OIL	200279	M 1381			
1.5 USA	(128AS)					OIL	200277	M 1379			516004
						OIL	200151	M 0629			

FORD (EUR)

B-MAX

	(JK)	10.12-			GAS	210344	MG1557	MG1558		516004
					GAS	211456	TG1559			516010

C-MAX

	(DM2)	02.07 - 09.10			GAS	210332	MG1525	MG1524	600480	516004
					GAS	211444	TG1522		600400	
	(DXA/CB7, DXA/CEU)	12.10-			GAS	210342	MG1551	MG1550		516004
					GAS	211444	TG1522		600400	

COUGAR

	(EC)	08.98 - 12.01			GAS	210322	MG1491			516004
					GAS	210326	MG1506			516004

ESCORT III/IV (80-90)

	(GAA, AWA)	09.80 - 08.81			OIL	200284	M 1411			516004
					GAS	210285	MG1412			
	(GAA, AWA)	09.81 - 05.83			OIL	200284	M 1411			516004
					GAS	210285	MG1412			
	(GAF, AWF, AVF, ABFT)	06.83 - 11.84			GAS	210286	MG1413			516004
					GAS	210285	MG1412			
	(GAF, AWF, AVF, ABFT)	12.84 - 01.86			GAS	210286	MG1413			516004
					GAS	210285	MG1412			
	(GAF, AWF, AVF, ABFT)	01.86 - 07.90			GAS	210286	MG1413			516004
					GAS	210285	MG1412			
	(GAF, AWF, AVF, ABFT)	06.83 - 11.84			GAS	210287	MG1414			516004
					GAS	210285	MG1412			
	(GAF, AWF, AVF, ABFT)	12.84 - 01.86			GAS	210287	MG1414			516004
					GAS	210285	MG1412			
	(GAF, AWF, AVF, ABFT)	02.86 - 07.90			GAS	210287	MG1414			516004
					GAS	210285	MG1412			
	(GAF, AWF, AVF, ABFT)	10.82 - 05.83								516004
					GAS	210285	MG1412			
	(GAF, AWF, AVF, ABFT)	06.83 - 11.84			GAS	210286	MG1413			516004
					GAS	210285	MG1412			
	(GAF, AWF, AVF, ABFT)	12.84 - 07.90			GAS	210286	MG1413			516004
					GAS	210285	MG1412			
	(GAF, AWF, AVF, ABFT)	06.83 - 11.84			GAS	210286	MG1413			516004
					GAS	210285	MG1412			
	(GAF, AWF, AVF, ABFT)	12.84 - 01.86			GAS	210286	MG1413			516004
					GAS	210285	MG1412			
	(ALD)	06.83 - 11.84			GAS	210286	MG1413			516004
					GAS	210285	MG1412			
	(ALF)	12.84 - 07.90			GAS	210286	MG1413			516004
					GAS	210285	MG1412			
	(ALD)	06.83 - 11.84			GAS	210286	MG1413			516004
					GAS	210285	MG1412			
	(ALF)	12.84 - 07.90			GAS	210286	MG1413			516004
					GAS	210285	MG1412			

FORD (EUR)

35, 55	(AVA)	01.81 - 05.83					OIL	201413	T 1425			516004
35, 55	(AVA)	06.83 - 11.84					OIL	200290	M 1426			516004
35, 55	(AVF)	12.84 - 09.90					OIL	200290	M 1426			516004
35, 55	(AVF)	12.84 - 09.90					OIL	201413	T 1425			516004

ESCORT V/VI (90-95)

1.1, 1.3 1.4	(GAL)	08.90 - 01.95 08.90 - 10.90		20A			GAS	210288	MG1417			516004
1.4 1.6	(GAL)	10.90 - 01.95 08.90 - 01.95		20B			GAS	210289	MG1421			516004
1.4i, 1.6i	(GAL)	08.90 - 01.95		20B			GAS	210289	MG1421			516004
1.8i excl.	(GAL)	01.92 - 01.95		20B			GAS	210289	MG1421			516004
1.8i	(GAL)	01.92 - 01.95		20B			GAS	210289	MG1421			516004
1.8 D	(GAL)	08.90 - 10.90		20A			GAS	210288	MG1417			516004
1.8 D, 1.8 TD	(GAL)	11.90 - 01.95		20B			GAS	210289	MG1421			516004
1.8 16V XR3i	(GAL)	02.92 - 01.95		20B			GAS	210289	MG1421			516004
RS 2000 4X2	(GAL)	09.92 - 01.95					GAS	210310	MG1469			516004
RS Turbo 4x4 excl. Cosworth	(GAL)	08.93 - 01.95					GAS	210310	MG1469			516004
RS Cosworth 4x4	(GAL)	09.92 - 01.95					GAS	210320	MG1488			516004
1.4	(GAL, AVL)	08.90 - 10.90		20A			GAS	210288	MG1417			516004
1.4, 1.8i 1.4i, 1.6, 1.6i, 1.6i 16V	(GAL, AVL)	10.90 - 01.95 08.90 - 01.95		20D			GAS	211412	TG1419			516004
1.8 D	(GAL, AVL)	08.90 - 10.90		20A			GAS	210288	MG1417			516004
1.8 D, 1.8 TD	(GAL, AVL)	10.90 - 01.95		20D			GAS	211412	TG1419			516004
	(ALL)	12.92 - 01.95		20B			GAS	210289	MG1421			516004
500 kg	(AVL)	07.90 - 12.94		20A			GAS	210288	MG1417			516004
700 kg	(AVL)	07.90 - 12.94		20B			GAS	210289	MG1421			516004

ESCORT VII (95-00)

1.3i	(GAL, AAL, ABL, AFL)	01.95 - 02.99		20C			GAS	210318	MG1485			516004
1.4i, 1.6i	(GAL, AAL, ABL, AFL)	01.95 - 02.99		20C			GAS	210318	MG1485			516004

FORD (EUR)

1.6i 16V, 1.8i, 1.8i 16V excl. 4X4	(GAL, AAL, ABL, AFL)	01.95 - 02.99		20C		GAS	210318	MG1485			516004
						GAS	211052	SG1474			
1.8 D, 1.8 TD	(GAL, AAL, ABL, AFL)	01.95 - 02.99		20C		GAS	210318	MG1485			516004
						GAS	211052	SG1474			
RS 2000 16V 4X2 excl. 4X4	(GAL, AAL, ABL, AFL)	01.95 - 02.99		20C		GAS	210318	MG1485			516004
1.6i 4x4 RS 2000 4x4 excl. Cosworth	(GAL, AAL, ABL, AFL)	01.95 - 10.98									516004
		01.95 - 10.98									
Clipper 1.3i	(GAL, ANL)	08.95 - 02.99		20A		GAS	210288	MG1417			516004
				20E		GAS	211436	TG1500			
Clipper 1.4i, 1.6i, 1.6i 16V, 1.8i, 1.8i 16V Clipper 1.8 D, 1.8 TD	(GAL, ANL)	01.95 - 08.95		20C		GAS	210318	MG1485			516004
		01.95 - 08.95		20D		GAS	211412	TG1419			
Clipper 1.4i, 1.6i, 1.6i 16V, 1.8i, 1.8i 16V Clipper 1.8 D, 1.8 TD	(GAL, ANL)	08.95 - 02.99		20C		GAS	210318	MG1485			516004
		08.95 - 02.99		20E		GAS	211436	TG1500			
	(ALL)	01.95 - 08.00		20C		GAS	210318	MG1485			516004
						GAS	211052	SG1474			
500 kg	(AVL)	01.95 -		20C		GAS	210318	MG1485			516004
						OIL	201414	T 1427			
700 kg	(AVL)	01.95 -		20C		GAS	210318	MG1485			516004
						OIL	201414	T 1427			

EXPLORER

	(U2)	01.91 - 10.94				GAS	211431	HG1493			
						GAS	211432	HG1494			
	(U2)	11.94 -				GAS	211433	HG1495			
						GAS	211434	HG1496			

FIESTA I

excl. XR2	(GFBT)	05.76 - 08.83				OIL	200291	M 1429			
						OIL	200292	M 1430			
XR2	(GFBT)	1981 - 08.83				GAS	210293	MG1431			
						OIL	200292	M 1430			

FIESTA II

excl. XR2	(FBD)	09.83 - 11.84				OIL	200294	M 1432			
						OIL	200292	M 1430			
excl. XR2	(FBD)	12.84 - 12.88				OIL	200294	M 1432			
						OIL	200292	M 1430			
XR2	(FBD)	09.83 - 11.84				GAS	210295	MG1433			
						OIL	200292	M 1430			
XR2	(FBD)	12.84 - 02.89				GAS	210295	MG1433			
						OIL	200292	M 1430			

FIESTA III

1.0, 1.1, 1.3, 1.4, 1.6, 1.8 D	(GFJ)	01.89 - 12.93		21A		GAS	210296	MG1434			516004
						GAS	211047	SG1435			
1.4 S, 1.6 S, 1.8 Si, 1.8 D, 1.8 TD	(GFJ)	01.89 - 12.93		21B		GAS	210297	MG1436			516004
						GAS	211047	SG1435			
1.6 XR2i, 1.8 16V XR2i, RS 1800	(GFJ)	01.89 - 12.93		21B		GAS	210297	MG1436			516004
						GAS	211047	SG1435			

FORD (EUR)

1.6 Turbo	(GFJ)	03.90 - 12.93		21B		GAS	210297	MG1436			516004
							GAS	211049	SG1468		
excl. Courier	(GFJ)	01.89 - 12.93		21A		GAS	210296	MG1434			516004
							GAS	211047	SG1435		
1.1, 1.3, 1.4 C, CLX, Ghia, Youth Senza barra stabilizzatrice - without stabilizer	(GFJ)	01.94 - 12.95		21A		GAS	210311	MG1471			516004
							GAS	211048	SG1465		
1.1, 1.3, 1.4 C, CLX, Ghia, Youth Con barra stabilizzatrice - with stabilizer	(GFJ)	01.94 - 12.95		21C		GAS	210311	MG1471			516004
							GAS	211048	SG1465		
1.1, 1.3 SX, 1.6 1.4 Si, SX, Futura	(GFJ)	01.94 - 12.95		21C		GAS	210311	MG1471			516004
		01.94 - 12.95					GAS	211048	SG1465		
1.6 LX, Si, Futura		01.94 - 12.95				GAS	210309	MG1467			516004
							GAS	211051	SG1472		
1.8 D Senza barra stabilizzatrice - without stabilizer	(GFJ)	01.94 - 12.95		21A		GAS	210311	MG1471			516004
							GAS	211048	SG1465		
1.8 TD	(GFJ)	01.94 - 12.95		21C		GAS	210311	MG1471			516004
							GAS	211048	SG1465		
XR2i, RS 1800 Con barra stabilizzatrice - with stabilizer		01.94 - 12.95				GAS	210309	MG1467			516004
							GAS	211051	SG1472		
excl. Fiesta Courier	(GFJ)	01.94 - 12.95		21C		GAS	210311	MG1471			516004
							GAS	211048	SG1465		

FIESTA III CLASSIC

1.1, 1.3, 1.4, 1.8 D	(GFJ)	12.95 - 12.97		21A		GAS	210311	MG1471			516004
							GAS	211048	SG1465		
1.1, 1.3, 1.4, 1.6, 1.8 TD	(GFJ)	12.95 - 12.97		21C		GAS	210311	MG1471			516004
							GAS	211048	SG1465		
1.6 LX, Si, Futura	(GFJ)	12.95 - 12.97				GAS	210309	MG1467			516004
							GAS	211051	SG1472		

FIESTA IV

1.0, 1.25, 1.3 16V, 1.4 16V excl. Fiesta Classic	(JA, JB)	08.95 - 10.98		21D		GAS	210313	MG1476	600310		516004
							GAS	211054	SG1477	600360	
1.0, 1.25, 1.3 16V	(JA, JB)	11.98 - 12.01		21E		GAS	210313	MG1476	600310		516004
							GAS	211057	SG1507	600360	
1.4 16V, 1.6	(JA, JB)	11.98 - 12.01		21D		GAS	210313	MG1476	600310		516004
							GAS	211054	SG1477	600360	
1.8 D, 1.8 DI excl. Fiesta Classic	(JA, JB)	08.95 - 10.98		21D		GAS	210316	MG1482	600310		516004
							GAS	211054	SG1477	600360	
1.8 D, 1.8 DI	(JA, JB)	11.98 - 12.01		21E		GAS	210316	MG1482	600310		516004
							GAS	211057	SG1507	600360	

FIESTA V

excl. ST150	(JH, JD)	11.01 - 12.03		22A		GAS	210330	MG1517	MG1516	600340	516004
							GAS	211442	TG1515	600460	
excl. ST150	(JH, JD)	01.04 -		22B		GAS	210487	MG2473	MG2474	600340	516004
							GAS	211442	TG1515	600460	

FIESTA VI

		10.08 -				GAS	210337	MG1537	MG1536	600450	516004
							GAS	211447	TG1538	600460	

FORD (EUR)

		09.12 -				GAS	210345	MG1561	MG1562			516004
							GAS	211457	TG1560			

FIESTA COURIER

	(F3L, F5L)	07.91 - 12.93		21B		GAS	210297	MG1436			516004
							GAS	211428			
	(F3L, F5L)	01.94 - 12.95		21C		GAS	210311	MG1471			516004
							GAS	211428			
	excl. 1.8 D	(J5, J3)	01.96 -				GAS	210313	MG1476	600310	516004
							GAS	211428	TG1466		
	1.8 D	(J5, J3)	01.96 -				GAS	210316	MG1482	600310	516004
							GAS	211428	TG1466		

FOCUS

	(DAW, DBW, DFW)	06.98 - 12.04				GAS	210324	MG1501	MG1502			516004
							GAS	211435	TG1498			
	(DNW)	06.98 - 12.04				GAS	210324	MG1501	MG1502			516004
							GAS	211437	TG1503			

FOCUS II

	(DA)	11.04 - 09.12				GAS	210332	MG1525	MG1524	600480	516004
							GAS	211444	TG1522		600400
	(DAW)	11.04 - 09.12				GAS	210332	MG1525	MG1524	600480	516004
							GAS	211445	TG1526		
		10.06 - 09.10				GAS	210332	MG1525	MG1524	600480	516004
							GAS	211453	TG1552		

FOCUS III

		04.11 -				GAS	210343	MG1553	MG1554	600480	516004
							GAS	211454	TG1555		600400
		05.11 - 10.14				GAS	210343	MG1553	MG1554	600480	516004
							GAS	211455	TG1556		
		09.14 -				GAS	212142	MG1569	MG1570	600480	516004
							GAS	211455	TG1556		600400

FOCUS C-MAX

		10.03 - 03.07				GAS	210332	MG1525	MG1524	600480	516004
							GAS	211444	TG1522		600400

FUSION

	(JU)	08.02 - 12.03		22A		GAS	210331	MG1519	MG1520	600340	516004
							GAS	211443	TG1518		
	(JU)	01.04 - 12.12		22B		GAS	210333	MG1527	MG1528	600340	516004
							GAS	211443	TG1518		

GALAXY

	4X2, 4X4 excl.	(WGR)	02.95 - 05.06				GAS	210314	MG1478	600800	516004	
							GAS	211429	TG1479			
		(WA6)	05.06 - 06.15				GAS	210334	MG1529	MG1530	600180	516004
							GAS	211446	TG1531		600190	

FORD (EUR)

GRANADA

	(GG_, GU, GNU)	01.72 - 04.85			no	OIL	201410	T 1403			
					+	OIL	201411	T 1404			
excl. 2.9 24V, 4X4	(GAE, GGE)	03.85 - 10.94				GAS	210298	MG1439			516004
				excl.		GAS	211415	TG1440			
2.9 24V excl. 4X4	(GAE, GGE)	04.91 - 10.94				GAS	210299	MG1441			516004
				excl.		GAS	211415	TG1440			
	(GAE, GGE)	02.92 - 10.94				GAS	210299	MG1441			516004

KA

	(RB)	09.96 - 10.98				GAS	210315	MG1480	600310	516004
				21D		GAS	211055	SG1481	600360	
	(RB)	11.98 - 03.00				GAS	210315	MG1480	600310	516004
				21E		GAS	211056	SG1504	600360	
	(RB)	04.00 - 04.03				GAS	210315	MG1480	600310	516004
						GAS	211058	SG1521	600360	
1.3i, 1.6i Street ka, Sport ka		04.03 - 12.07				GAS	210336	MG1535	MG1534	516004
						GAS	211058	SG1521	600360	
	(RU8)	02.09 -				GAS	210168	MG0673	MG0672	516004
						GAS	211302	TG0675		

KUGA

		03.08 -				GAS	210340	MG1545	MG1544	600480	516004
						GAS	211450	TG1546	600400	516010	
	(DM2)	03.13 -				GAS	212133	MG1567	MG1568		516004
						GAS	211450	TG1546		516010	

MAVERICK

	(UDS, UNS)	02.93 - 06.96				GAS	211644	HG2861			
						GAS	211653	HG2880			
2WD, 4WD	(1EZ)	12.00 -									

MONDEO I

excl. , 4X4	(GBP)	03.93 - 05.93				GAS	210305	MG1459			516004
						GAS	210306	MG1460			516004
excl. , 4X4	(GBP)	06.93 - 08.96				GAS	210307	MG1461			516004
						GAS	210306	MG1460			516004
4X4 excl.	(BNP)	01.95 - 08.96				GAS	210307	MG1461			516004
				excl.							516004
Clipper excl. , 4X4	(BNP)	03.93 - 05.93				GAS	210305	MG1459			516004
				excl.		GAS	211427	TG1463			
Clipper excl. , 4X4	(BNP)	06.93 - 08.96				GAS	210307	MG1461			516004
				excl.		GAS	211427	TG1463			
Clipper 4X4 excl.	(BNP)	01.95 - 08.96				GAS	210307	MG1461			516004
				excl.		GAS	211427	TG1463			

MONDEO II

FORD (EUR)

 excl. 2.5 ST200, 1*	(BAP, BFP)	09.96 - 10.00				GAS	210322	MG1491			516004
						GAS	210306	MG1460			516004
Clipper excl. 1*	(BNP)	09.96 - 10.00				GAS	210322	MG1491			516004
				excl. 1*		GAS	211427	TG1463			

MONDEO III

excl. 3.0 24V, ST220	(B4Y, B5Y)	10.00 - 08.07				GAS	210327	MG1508			516004
						GAS	210328	MG1509			516004
Clipper excl. 3.0 24V, ST220	(BWY)	10.00 - 08.07				GAS	210327	MG1508			516004
						GAS	211438	TG1510			

MONDEO IV

	(BA7)	03.07 - 01.15				GAS	210334	MG1529	MG1530	600180	516004
						GAS	211446	TG1531		600190	516010

MONDEO V

		09.14 -				GAS	212112	MG1565	MG1564		516004
						GAS	212113	TG1566			

ORION I/II

 excl. 1.6i, 1.6 D	(AFD)	07.83 - 11.84				GAS	210286	MG1413			516004
						GAS	210285	MG1412			
 excl. 1.6i, 1.6 D	(AFD)	12.84 - 07.90				GAS	210286	MG1413			516004
						GAS	210285	MG1412			
1.6i	(AFD)	01.83 - 11.84				GAS	210286	MG1413			516004
						GAS	210285	MG1412			
1.6i	(AFF)	12.84 - 07.90				GAS	210286	MG1413			516004
						GAS	210285	MG1412			
1.6 D	(AFF)	02.84 - 11.84				GAS	210287	MG1414			516004
						GAS	210285	MG1412			
1.6 D	(AFF)	12.84 - 07.90				GAS	210287	MG1414			516004
						GAS	210285	MG1412			

ORION III

1.3 1.4	(GAL)	08.90 - 12.93 08.90 - 10.90		20A		GAS	210288	MG1417			516004
						GAS	211045	SG1418			
1.4 1.4i, 1.6, 1.6i, 1.8i excl.Ghia	(GAL)	10.90 - 12.93 08.90 - 12.93		20B		GAS	210289	MG1421			516004
						GAS	211045	SG1418			
1.4i, 1.6i, 1.8i Ghia	(GAL)	08.90 - 12.93		20B		GAS	210289	MG1421			516004
						GAS	211045	SG1418			
1.8 D	(GAL)	08.90 - 10.90		20A		GAS	210288	MG1417			516004
						GAS	211045	SG1418			
1.8 D, 1.8 TD	(GAL)	11.90 - 12.93		20B		GAS	210289	MG1421			516004
						GAS	211045	SG1418			

PICK-UP

Cortina, Taunus (1000 Kg)		1982 - 07.83				OIL	201424	H 1455			
Cortina, Taunus (1000 Kg)		08.83 - 1988				OIL	201424	H 1455			
						OIL	201425	H 1456			

FORD (EUR)

2.0, 1.8 TD		10.87 - 12.92												
						OIL	201426	H 1457						

PROBE

excl. 3.0 V6,		08.88 - 07.93				GAS	210462	MG2413						
						GAS	210463	MG2414						
2.0 16V, 2.5 24V		07.93 - 03.98				GAS	210464	MG2415	MG2416					
						GAS	210465	MG2417						

PUMA

1.4, 1.6, 1.7	(EC)	03.97 - 10.98				GAS	210323	MG1492		600310	516004			
				21D		GAS	211054	SG1477		600360				
1.4, 1.6, 1.7	(EC)	11.98 - 06.02				GAS	210323	MG1492		600310	516004			
				21E		GAS	211057	SG1507		600360				

S-MAX

	(VA6)	05.06 - 12.14				GAS	210334	MG1529	MG1530	600180	516004			
						GAS	211446	TG1531		600190				

SCORPIO I

excl. 2.9 24V, 4X4	(GAE, GGE)	03.85 - 10.94				GAS	210298	MG1439						516004
				excl.		GAS	211415	TG1440						
2.9 24V excl. 4X4	(GAE, GGE)	04.91 - 10.94				GAS	210299	MG1441						516004
				excl.		GAS	211415	TG1440						
		02.92 - 10.94				GAS	210299	MG1441						516004

SCORPIO II

2.0, 2.0 16V, 2.3 16V	(GFR, GGR)	10.94 - 08.98				GAS	210335	MG1533	MG1532					516004
2.5 TD, 2.9, 2.9 24V				excl.		GAS	211415	TG1440						

SIERRA

excl. XR4i	(GBC)	08.82 - 04.84				GAS	210300	MG1442						516004
						GAS	211416	TG1443						
2.8 XR4i	(GBC)	08.82 - 04.84				GAS	210300	MG1442						516004
						GAS	211416	TG1443						
1.6, 1.8, 2.0 excl. 4X4, RS Cosworth	(GBC, GBG)	05.84 - 02.93				GAS	210301	MG1445						516004
1.8 TD, 2.3 D excl. 4X4						GAS	211416	TG1443						
2.8 V6, 2.9 V6, XR4i	(GBC, GBG)	05.84 - 02.93				GAS	210301	MG1445						516004
excl. 4X4, RS Cosworth						GAS	211416	TG1443						
4x4 excl. RS Cosworth	(GBC, GBG)	05.84 - 02.93				GAS	210321	MG1489						516004
4x2 RS Cosworth	(GBC, GBG)	1986 - 1990				GAS	210312	MG1472						516004
4x4 RS Cosworth	(GBC, GBG)	1990 - 1993				GAS	210321	MG1489						516004
excl. 4X4	(BNC)	08.82 - 04.84				GAS	210300	MG1442						516004
excl. 4X4	(BNC, BNG)	05.84 - 02.93				GAS	210301	MG1445						516004

FORD (EUR)

4x4	(BNC, BNG)	05.84 - 02.93				GAS	210321	MG1489			516004
						GAS					

TOURNEO

Couirier Kombi excl. Connect, Grand Connect Kombi, Custom autobus		09.13 -				GAS	210344	MG1557	MG1558		516004
						GAS	211457	TG1560			516010

TRANSIT

FT 75, FT 100 FT 80, FT 100, FT 120 x= 2.69 m	(71E, 72E, 73E, 74E, 81E,V)	09.70 - 12.77 01.78 - 10.85				OIL	201418	T 1447				
						OIL	201420	T 1449				
FT 125, FT 130, FT 150, FT 175 FT 100L, FT 130, FT 160, FT 190 x= 3.02 m	(71E, 72E, 73E, 74E, 81E,V)	09.70 - 12.77 01.78 - 10.85				OIL	201418	T 1447				
						OIL	201420	T 1449				
	(71E, 72E, 73E, 74E, 81E,V)	09.70 - 12.85				OIL	201418	T 1447				
						OIL	201420	T 1449				
80, 100, 115, 120 x= 2.82 m	(T)	11.85 - 08.91				OIL	200302	M 1450			516007	
						OIL	201421	H 1451				
100L, 130, 160, 190 x= 3.02 m, 3.47 m	(T)	11.85 - 08.91				OIL	201422	H 1452			516007	
						OIL	201421	H 1451				
80, 100, 115, 120, 150 S e+e = 2.84 m	(E)	09.91 - 08.94				OIL	200303	M 1453			516007	
						GAS	210303	MG1453			516007	
						OIL	201418	T 1447				
130, 150 S, 100 L, 150 L, 190 L e+e = 3.57 m	(E)	09.91 - 08.94				OIL	200303	M 1453			516007	
						GAS	210303	MG1453			516007	
						OIL	201423	H 1454				
190 e+e = 3.57 m	(E)	09.91 - 08.94				OIL	200303	M 1453			516007	
						GAS	210303	MG1453			516007	
						OIL	201418	T 1447				
80, 100, 115, 120 e+e = 2.84 m	(E)	09.94 - 12.99				OIL	200303	M 1453			516007	
						GAS	210303	MG1453			516007	
						OIL	201418	T 1447				
150 S e+e = 2.84 m	(E)	09.94 - 12.99				OIL	200303	M 1453			516007	
						GAS	210303	MG1453			516007	
						OIL	201423	H 1454				
100L, 130, 150 L, 190 L e+e = 3.57 m	(E)	09.94 - 12.99				OIL	200303	M 1453			516007	
						GAS	210303	MG1453			516007	
						OIL	201423	H 1454				
190, 190EF e+e = 3.57 m	(E)	09.94 - 12.99				GAS	210303	MG1453			516007	
Tourneo, excl. 350L 	(FA_Y, FB_Y, FC_Y, FD_Y, FM_Y, FN_Y, FS_Y, FZ_Y)	01.00 - 05.06		23A		GAS	210329	MG1511			516007	
							OIL	201439	T 1512			
							GAS	211439	TG1512			
	(FA_Y, FB_Y, FC_Y, FD_Y, FM_Y, FN_Y, FS_Y, FZ_Y)	01.00 - 05.06		23B		GAS	210329	MG1511			516007	
							OIL	201440	T 1513			
							GAS	211440	TG1513			

FORD (EUR)

e ⁺ e = 2.93 m excl. □ e ⁺ e = 3.13 m excl. □ 	(FB_Y, FC_Y, FD_Y, FM_Y, FN_Y, FS_Y, FZ_Y)	01.00 - 05.06 01.00 - 05.06				GAS	210329	MG1511		516007
				23C		OIL	201441	H 1514		
e ⁺ e = 3.30 m, e ⁺ e = 3.75 m e ⁺ e = 3.50 m, e ⁺ e = 3.95 m excl. ■■, □ 	(FA_Y, FB_Y, FC_Y, FD_Y, FM_Y, FN_Y, FS_Y, FZ_Y)	01.00 - 05.06 01.00 - 05.06				GAS	210329	MG1511		516007
				23C		OIL	201441	H 1514		
300M, 300S Incl. Tourneo		07.06 -				GAS	210339	MG1542	600490	516007
				23D		GAS	211449	HG1543		
330L, 330M, 350L, 350M Incl. Tourneo		07.06 -				GAS	210341	MG1549	600490	516007
				23E		GAS	211451	TG1547		
Incl. Tourneo		07.06 -				GAS	210341	MG1549	600490	516007
				23F		GAS	211452	TG1548		
330S 330S Incl. Tourneo		07.06 -				GAS	210341	MG1549	600490	516007
				23C		GAS	211441	TG1514		
Courier Kombi excl. Connect, Furgonato, Custom, Pianale		01.14 -				GAS	210344	MG1557 MG1558		516004
						GAS	211457	TG1560		516010

TRANSIT CONNECT - TOURNEO CONNECT

	(P65, P70, P80)	06.02 - 12.13				GAS	210338	MG1539 MG1540	600470	516004
						GAS	211448	HG1541		

HONDA (J)

ACCORD I/II

	(SY, AC, AD)	10.81 - 05.85				GAS	210346	MG1602			516004
						GAS	210347	MG1603			516004

ACCORD III

	(CA4, CA5)	06.85 - 12.89				GAS	210348	MG1604			516004
						GAS	210349	MG1605			516004

ACCORD IV

excl. 4WS	(CB1, CB3)	01.90 - 03.93				GAS	210350	MG1606			516004
						GAS	210351	MG1607			516004
4WS	(CB7)	01.90 - 03.93				GAS	210350	MG1606			516004
Aerodeck	(CB8)	01.91 - 12.93				GAS	210350	MG1606			516004
						GAS	210352	MG1608			516004

ACCORD V

	(CC7)	03.93 - 02.96				GAS	210350	MG1606			516004
						GAS	210351	MG1607			516004
2.0	(CC1)	03.93 - 01.96				GAS	210350	MG1606			516004
						GAS	210376	MG1642			516004
, 2.0, 2.2	(CD7, CD9, CE1, CE2)	09.93 - 09.98				GAS	210350	MG1606			516004
						GAS	210374	MG1636			516004

ACCORD VI

1.8, 2.0, 2.2	(CE7, CE8, CE9)	01.96 - 09.98				GAS	210350	MG1606			516004
			2.0 D, 2.0 TD	(CF)	01.96 - 09.98				GAS	210376	MG1642

ACCORD VII

1.6, 1.8, 2.0, 2.0 TD	(CG7, CG8, CG9, CH2)	10.98 - 01.03				GAS	211061	SG1643			
						GAS	211062	SG1644			
2.0 16V, 2.3 Vti	(CG4, CG3)	02.98 - 01.03				GAS	211066	SG1655			
						GAS	211067	SG1656			

ACCORD VIII

2.0i, 2.4i, 2.2 CDTi	(CL7, CL9, CN1)	02.03 - 09.12				GAS	210384	MG1672			516004
						GAS	211070	SG1673			
2.0, 2.4, 2.2 CDTi	(CM1, CM2, CN2)	02.03 - 09.12				GAS	210384	MG1672			516004
						GAS	211071	SG1674			

ACCORD IX

excl.	(CU)	07.08 -				GAS	210391	MG1693	MG1692			516004
						GAS	211075	SG1694				

CIVIC I/II

	(SL)	10.79 - 12.81				GAS	210353	MG1609			516004
						GAS	210354	MG1610			516004
	(SL)	01.82 - 09.83									516004
						GAS	210354	MG1610			516004

HONDA (J)

excl. CRX, Shuttle	(AG, AH, AI, AK, AL, AM)	10.83 - 10.87				GAS	210355	MG1611			516004
						GAS	211059	SG1612			

CIVIC III/BALLADE

1.2, 1.3, 1.4 1.5, 1.6 > Ch. S100001	(EC_) (ED_)	10.87 - 12.88				GAS	210356	MG1613			516004
		10.87 - 12.88				GAS	210357	MG1614			516004
1.2, 1.3, 1.4 1.5, 1.6 Ch. S100002 >	(EC_) (ED_)	01.89 - 11.91				GAS	210358	MG1615			516004
		01.89 - 11.91				GAS	210359	MG1616			516004
1.6 4X4 Ch. S10...> S200000	(EE5)	01.89 - 12.90				GAS	210360	MG1617			516004
						GAS	210361	MG1618			516004
1.6 4X4 Ch. S200001 >	(EE5)	01.90 - 11.91				GAS	210360	MG1617			516004
						GAS	210362	MG1619			516004

CIVIC IV/BALLADE

1.3, 1.5 1.6 1.5, 1.6	(EG_) (EH_) (EJ_)	10.91 - 11.95				GAS	210378	MG1649	MG1650		516004
		10.91 - 03.96				GAS	210363	MG1622			516004

CIVIC IV/V

1.4, 1.5 1.6, 1.8	(MA_) (MB_)	09.94 - 02.01				GAS	210378	MG1649	MG1650		516004
						GAS	210365	MG1625			516004
1.4, 1.5, 1.6	(EJ9) (EK_)	11.95 - 02.01				GAS	210378	MG1649	MG1650		516004
						GAS	210365	MG1625			516004

CIVIC V

1.6 1.6 VTEC, VTI	(EJ6) (EJ7, EJ8, EM1)	11.95 - 02.01				GAS	211063	SG1645			
		11.95 - 02.01				GAS	210365	MG1625			516004
2.0 ltd	(MB7)	01.97 - 02.01				GAS	211069	SG1671			516004
Aerodeck 1.4, 1.5, 1.6, 1.8, 2.0i TD	(MB_, MC_)	04.98 - 02.01				GAS	210378	MG1649	MG1650		516004
						GAS	211069	SG1671			

CIVIC VI

(3 m), excl. 1.7 CTDi, 2.0 sport, R type	(EM2, EP1, EP2, ES4, ES5)	02.01 - 09.05				GAS	210385	MG1675	MG1676		516004
						GAS	211064	SG1651			
(5 m) excl. 1.7 CTDi, 2.0 sport, R type	(EU5/7, EU6/8)	02.01 - 02.06				GAS	210385	MG1675	MG1676		516004
						GAS	211068	SG1670			
(3/5 m) 1.7 CTDi (5 m) 2.0i (3 m) 2.0 R type	(EP_, EU9)	04.02 - 02.06				GAS	210386	MG1677	MG1678		516004
						GAS	211068	SG1670			
(5m) 2.0i	(EV1)	09.03 - 02.06				GAS	210386	MG1677	MG1678		516004
						GAS	211068	SG1670			

CIVIC VIII

excl.	(FD)	09.05 - 09.12				GAS	210388	MG1685	MG1684		516004
						GAS	211466	TG1686			
excl. Hybrid	(FD)	09.05 - 09.12				GAS	212099	MG6701	MG6700		516004
						GAS	212100	TG6702			

HONDA (J)

CIVIC/BALLADE SHUTTLE II

1.4, 1.5, 1.6 4X4 > Ch. S100001	(EE1, EE2, EE4)	01.88 - 12.88				GAS	210362	MG1619			516004
1.4, 1.5, 1.6 4X4 Ch. S100002 > S200000	(EE1, EE2, EE4)	01.89 - 12.89				GAS	210360	MG1617			516004
1.4, 1.5, 1.6 4X4 Ch. S200001 >	(EE1, EE2, EE4)	01.90 - 02.95				GAS	210360	MG1617			516004
						GAS	210362	MG1619			516004

CIVIC/BALLADE CRX I

CRX 1.5, 1.6 excl. 1.6 DOHC	(AF, AS)	10.83 - 10.87				GAS	210355	MG1611			516004
						GAS	211059	SG1612			516010

CIVIC/BALLADE CRX II

CRX 1.6i 16V > Ch. S100001	(ED9)	10.87 - 12.88				GAS	210356	MG1613			516004
						GAS	210357	MG1614			516004
CRX 1.4 Ch. S200001 > CRX 1.6 DOHC Ch. S10... >	(EE6) (EE6, EE8, ED9)	01.90 - 02.92				GAS	210358	MG1615			516004
		01.89 - 02.92				GAS	210359	MG1616			516004
CRX 1.6 SOHC Ch. S100002 >	(ED9)	01.89 - 02.92				GAS	210358	MG1615			516004
						GAS	210357	MG1614			516004

CIVIC/BALLADE CRX III

CRX 1.6i ESI	(EH6)	03.92 - 12.98				GAS	210378	MG1649	MG1650		516004
CRX 1.6i Vti	(EG2)	03.92 - 12.98				GAS	210363	MG1622			516004

CONCERTO

	(HW)	08.89 - 03.95				GAS	210364	MG1623	MG1624		516004
						GAS	210365	MG1625			516004

CR-V

	(RD)	10.95 - 07.02				GAS	211060	SG1641			
						GAS	211065	SG1652			
	(RD)	07.02 - 09.06				GAS	210387	MG1679	MG1680		516004
						GAS	211072	SG1681			

CR-V III

	(RE)	01.07 - 12.11				GAS	210392	MG1695	MG1696		516004
				excl. Xeno		GAS	211076	SG1697			

CR-V IV

excl. 4WD	(RE)	10.12 -				GAS	210392	MG1695	MG1696		516004
						GAS	211077	SG1698			

HR-V

1.6 16V 4x2	(GH)	03.99 -				GAS	210381	MG1661	MG1662		516004
1.6 16V 4x4	(GH)	03.99 -				GAS	211463	TG1660			

INTEGRA/QUINT

	(AV, DA)	02.85 - 04.89				GAS	210366	MG1626			516004
						GAS	211059	SG1612			

HONDA (J)

JAZZ

	(GD)	03.02 - 04.05				GAS	210382	MG1665	MG1666			516004
						GAS	211464	TG1664				516010
	(GD)	04.05 - 07.08				GAS	210389	MG1687	MG1688			516004
						GAS	211464	TG1664				516010
	(GE)	07.08 -				GAS	210390	MG1689	MG1690			516004
						GAS	211467	TG1691				516010

LEGEND

2.5	(HS)	01.86 - 1988				GAS	210367	MG1627				516004
						GAS	210672	MG3502				516004
2.7	(KA4)	1989 - 12.90				GAS	210367	MG1627				516004
						GAS	210368	MG1629				516004
	(KA7)	01.91 - 02.96										516004
												516004

LOGO

1.3	(GA3)	03.99 - 03.02				GAS	210380	MG1657	MG1658			516004
						GAS	211462	TG1659				516010

PASSPORT/JAZZ

	(AA)	01.94 - 12.97				GAS	211460	HG1639				
						GAS	211459	HG1638				
		01.98 - 12.02				GAS	211460	HG1639				
						GAS	211461	HG1640				

PRELUDE II/III

	(AB, BA1, BA2)	11.83 - 09.87				GAS	210369	MG1630				516004
						GAS	210347	MG1603				516004
excl. 4 WS	(BA)	10.87 - 01.92				GAS	210370	MG1631				516004
						GAS	210371	MG1632				516004

PRELUDE IV

	(BB1, BB2, BB3)	02.92 - 09.96				GAS	210373	MG1634				516004
						GAS	210372	MG1633				516004

PRELUDE V

excl. 2.2 Vfi-S	(BB5, BB6, BB8, BB9)	10.96 - 10.00				GAS	211073	SG1683	SG1682			
						GAS	210372	MG1633				516004

QUINTET





	(SU, TU, TL, TS)	02.80 - 12.84				GAS	210353	MG1609				516004
						GAS	210354	MG1610				516004

SHUTTLE/ODYSSEY

	(RA1, RA3)	01.95 - 12.97				GAS	210379	MG1653	MG1654			516004
						GAS	210375	MG1637				516004

HONDA (J)

STREAM

	(RN1, RN3)	05.01 -				GAS	210383	MG1667	MG1668			516004
						GAS	211465	TG1669				

HYUNDAI (KO)

ACCENT/PONY/EXCEL

1.2, 1.4		01.77 - 12.84			/	OIL	200024	C 1703			516004
								∞	GAS	211468	TG1704
1.3, 1.6		10.85 - 08.89			/	GAS	210025	CG1705			516004
								∞	GAS	211469	TG1706
	(X2)	09.89 - 08.94			/	GAS	210394	MG1707			516004
								∞	GAS	211469	TG1706

ACCENT I

	(X3)	09.94 - 04.97			/	GAS	210397	MG1717	MG1718			516004
							24A	/	GAS	210400	MG1725	MG1724
	(X3)	05.97 - 01.00			/	GAS	210397	MG1717	MG1718			516004
							24B	/	GAS	210407	MG1745	MG1746

ACCENT II

	(LC)	01.00 - 10.05			/	GAS	210406	MG1743	MG1744			516004
							24B	/	GAS	210407	MG1745	MG1746

ACCENT III

	(MC)	11.05 - 12.09			/	GAS	210414	MG1771	MG1770			516004
								∞	GAS	211482	TG1772	

ACCENT IV

	(RB)	11.10 -			/	GAS	210918	MG5583	MG5584			516004
								∞	GAS	211487	TG1780	

ATOS/SANTRO

	(MX)	11.97 - 10.98		25A	/	GAS	210398	MG1719	MG1720			516004
								∞	GAS	211471	TG1721	
	(MX)	11.98 -		25B	/	GAS	210403	MG1737	MG1738			516004
								∞	GAS	211471	TG1721	

ATOS PRIME

	(MX)	11.98 -		25B	/	GAS	210403	MG1737	MG1738			516004
								∞	GAS	211471	TG1721	

COUPÉ

	(RD)	06.96 - 04.02 06.96 - 04.02			/	GAS	210399	MG1723	MG1722			516004
								/	GAS	210401	MG1733	MG1732
	(GK)	03.02 - 08.09			/	GAS	210404	MG1739	MG1740			516004
								/	GAS	210405	MG1741	MG1742

GALLOPER

	(JK-01)	08.98 - 12.03			±	GAS	211474	TG1729			
								∞	GAS	211597	HG2617

GETZ

	(TB)	08.02 - 12.10			/	GAS	210402	MG1735	MG1734			516004
								∞	GAS	211476	TG1736	

HYUNDAI (KO)

H1/SATELLITE/STAREX

	(KMJ)	06.97 - 2007			♂	GAS	211472	TG1726			
					♀	GAS	211473	TG1727			
	(KMJ, KMF)	06.97 - 2007			♂	GAS	211472	TG1726			
					♀	GAS	211483	TG1773			

H1

	Travel cargo	(TQ)	02.08 -			♂	GAS	212121	MG1797	MG1796			
						♀	GAS	212122	TG1798				

H100

	FD Series		07.93 - 10.04			♂	GAS	211489	HG1901			
						♀	GAS	211470	HG1712			

i10

	(PA)	10.07 - 12.17			♂	GAS	210903	MG5539	MG5538			516004
					♀	GAS	211486	TG1777				

i10 II

	(BA, IA)	08.13 -			♂	GAS	212103	MG1793	MG1794			516004
					♀	GAS	212104	TG1795			516010	

i20

	(PB, PBT)	09.08 -			♂	GAS	210415	MG1779	MG1778			516004
					♀	GAS	211487	TG1780				

i30

	O.E. 54651-2R100 / 54651-2R200 O.E. 54661-2R100 / 54661-2R200	(FD)	10.07 - 11.11			♂	GAS	210417	MG1783	MG1784			516004
						♀	GAS	211484	TG1774				
	O.E. 54651-2L100 / 54651-2L200 / 54651-2L600 O.E. 54661-2L100 / 54661-2L200 / 54661-2L600	(FD)	10.07 - 11.11			♂	GAS	210416	MG1781	MG1782			516004
						♀	GAS	211484	TG1774				
	CW	(FD)	10.07 - 06.12			♂	GAS	210416	MG1781	MG1782			516004
						♀	GAS	211484	TG1774				

i30 II

	excl. CW	(GD)	10.11 -			♂	GAS	212107	MG1791	MG1792			516004
						♀	GAS	211484	TG1774				

i40

	excl. CW	(VF)	03.12 -			♂	GAS	210418	MG1785	MG1786			516004
						♀	GAS	211488	TG1787				
	CW	(VF)	07.11 -			♂	GAS	210418	MG1785	MG1786			516004
						♀	GAS	211488	TG1787				

ix20

	(JC)	11.10 -			♂	GAS	212146	MG5585	MG5586			516004
					♀	GAS	211487	TG1780				

ix35

HYUNDAI (KO)

excl. 4WD	(LM, EL, ELH)	01.10 -				GAS	210916	MG5577	MG5578			516004
							GAS	212039	TG5579			
4WD	(LM, EL, ELH)	01.10 -				GAS	210916	MG5577	MG5578			516004
							GAS	212040	TG5580			

LANTRA/ELANTRA

	(J1)	12.90 - 09.95				GAS	210393	MG1701				516004
							GAS	211078	SG1702			
	(J2)	11.95 - 10.00 02.96 - 10.00				GAS	210399	MG1723	MG1722			516004
							GAS	210401	MG1733	MG1732	600261	600262
	(XD)	06.00 - 07.06				GAS	210399	MG1723	MG1722			516004
							GAS	210411	MG1757	MG1756	600261	600262
	(HD)	11.05 - 12.11				GAS	210416	MG1781	MG1782			516004
							GAS	211484	TG1774			

MATRIX

	(FC)	06.01 - 08.10				GAS	210408	MG1747	MG1748			516004
							GAS	210409	MG1749	MG1750	600261	600262

S COUPÉ

	(SLC)	09.89 - 05.96				GAS	210394	MG1707				516004
							GAS	211469	TG1706			

SANTA FÉ

	(SM)	02.01 - 03.06				GAS	210412	MG1759	MG1758			516004
							GAS	211480	TG1760			
	(CM)	03.06 - 12.12				GAS	210413	MG1767	MG1768			516004
							GAS	211481	TG1769			

SANTAMO

		10.98 - 12.02				GAS	210522	MG2620				516004
							GAS	211600	TG2621			

SONATA/SONICA

	(Y2)	10.88 - 04.93				GAS	210395	MG1708				516004
							GAS	211079	SG1709			
	(Y3)	05.93 - 06.98				GAS	210396	MG1715				516004
							GAS	211080	SG1731			
	(EF)	06.98 - 04.00				GAS	211081	SG1761				
				26A			GAS	211082	SG1762			
	(EF)	04.00 - 04.01				GAS	211081	SG1761				
				26B			GAS	211084	SG1764			
	(EF)	04.01 - 11.04				GAS	211085	SG1765				
				26B			GAS	211084	SG1764			
	(NF)	01.05 - 12.10				GAS	211087	SG1775				
		02.06 - 12.10					GAS	211485	TG1776			
	excl Hybrid	01.09 - 12.15										
							GAS	211488	TG1787			

HYUNDAI (KO)

TERRACAN

	(HP)	05.01 - 12.06			±	GAS	211478	TG1754			
					±	GAS	211479	TG1755			

TRAJET

	(FO)	03.00 - 07.08				GAS	210410	MG1751	MG1752			516004
					∞	GAS	211477	TG1753				

TUCSON

	(JM)	08.04 - 06.15				GAS	210907	MG5553	MG5554			516004
						GAS	210908	MG5555	MG5556	600261	600262	516004
excl. 4WD	(LM, EL, ELH)	01.10 -				GAS	210916	MG5577	MG5578			516004
					±	GAS	212039	TG5579				

XG

	(XG)	12.98 - 12.05				GAS	211081	SG1761			
				26A		GAS	211082	SG1762			
				26B		GAS	211084	SG1764			

INNOCENTI (I)

ELBA

	-146	04.86 - 12.96				OIL	200253	M 1331			
			POST			OIL	200268	M 1363			

KORAL

		1980 -				OIL	200804	M 4601			
			POST			OIL	200244	M 1312			

MILLE

		1994 - 1995				OIL	200421	M 1803			
			POST			OIL	200422	M 1804			

MINI, 90, 120

Mini 1001, 1300 90, 120, De Tomaso		1974 - 1982				OIL	201271	T 0409			
		1974 - 1982	POST			OIL	201273	T 0411			

MINI 3 CILINDRI

		1990 -				OIL	200419	M 1801			
			POST			OIL	200420	M 1802			

ISUZU (J)

GEMINI

PF 50, PF 60		1974 - 1979			½	OIL	201661	T 2903			
					½	OIL	201675	T 2922			

PIAZZA

JR 130		1981 - 1982			½	OIL	201661	T 2903			
					½	GAS	211674	TG2921			

PICK-UP

KB 2, KBD 2 (4X2)		1980 - 07.86			½	GAS	211489	HG1901			
					⊗	GAS	211596	HG2616			
KB 2, KBD 2 (4X2)		08.86 -			½						
					⊗	GAS	211596	HG2616			
KB 4, KBD 4 (4X4)		1980 -			½	GAS	211489	HG1901			
					⊗	GAS	211490	HG1902			
TFR Series CAMPO/BRAVA (4X2)		1988 -			½						
					⊗						
TFS Series CAMPO/BRAVA (4X4)		1988 -			½	GAS	211670	HG2916			
					⊗	GAS	211490	HG1902			

TROOPER / BIG HORN

4X4	(UBS)	1983 - 10.86			½	GAS	211489	HG1901			
					⊗	GAS	211490	HG1902			
4X4 excl. 15	(UBS)	11.86 - 1991			½	GAS	211670	HG2916			
					½	GAS	211459	HG1638			
	(UB)	1992 - 1996			½	GAS	211670	HG2916			
					⊗	GAS	211680	HG2930			
2m		1996 -			½	GAS	211688	HG2949			
					⊗	GAS	211680	HG2930			
4m		1996 -			½	GAS	211688	HG2949			
					⊗	GAS	211680	HG2930			
4X4 excl. 15	(UBS)	02.98 -			½	GAS	211493	HG1906			
					⊗	GAS	212001	HG5204			

IVECO (I)

DAILY, TURBO DAILY

28F8/U8 30.8 > Ch. 304675 35.8, 35.9, 35.10 40.8, A 40.8, 40.10, A 40.10		01.78 - 08.89		27A	☉	OIL	201393	T 1344			
		01.78 - 08.89									
		01.78 - 08.89		27B	☉	OIL	201394	T 1345			
		01.78 - 08.89									
30.8 Ch. 304676 >		01.78 - 08.89		N.D. 27C	☉	OIL	201406	T 1386			
				H.D. 27C	☉	OIL	202021	H 5402			
				27B	☉	OIL	201394	T 1345			
30.8, 30.9 New Daily 35.8, 35.10, 35.12 New Daily 40.8, A 40.8 New Daily		09.89 - 04.99		N.D. 27C	☉	OIL	201406	T 1386			
				H.D. 27C	☉	OIL	202021	H 5402			
				27C	☉	OIL	201408	T 1388			
				27D	☉	OIL	201287	T 0633			
35.8 CB 5, 40.8, A 40.8		08.89 - 04.99		N.D. 27D	☉	OIL	201287	T 0633			
				H.D. 27D	☉	OIL	202022	H 5403			
				27B	☉	OIL	201394	T 1345			
35.10 V, 45.10, A 45.10		08.89 - 04.99		N.D. 27D	☉	OIL	201287	T 0633			
				H.D. 27D	☉	OIL	202022	H 5403			
				27E	☉	OIL	201408	T 1388			
45.10, A 45.10, 49.10 New Turbo Daily		09.89 - 04.99		N.D. 27D	☉	OIL	201287	T 0633			
				H.D. 27D	☉	OIL	202022	H 5403			
				27D	☉	OIL	201287	T 0633			
49.10, 49.12		09.89 - 04.99		N.D. 27D	☉	OIL	201287	T 0633			
				H.D. 27D	☉	OIL	202022	H 5403			
				27E	☉	OIL	201408	T 1388			
40 NC 35		08.89 - 04.99		27B	☉	OIL	201394	T 1345			
				27A	☉	OIL	201393	T 1344			

DAILY S2000

35S9, 35S11, 35S13, 35S15		05.99 -		27F	☉	OIL	201286	T 0632			
				N.D. 27H	☉	OIL	201288	T 0634			
				H.D. 27H	☉	OIL	202023	H 5404			
35C9, 35C11, 35C13, 35C15		05.99 -		27F	☉	OIL	201286	T 0632			
				27G	☉	OIL	201287	T 0633			
				N.D. 27H	☉	OIL	201288	T 0634			
50C11, 50C13, 50C15		05.99 -		27G	☉	OIL	201287	T 0633			
				N.D. 27H	☉	OIL	201288	T 0634			
				H.D. 27H	☉	OIL	202023	H 5404			

MASSIF

		10.08 -			☉	OIL	201309	H 0698			
					☉	GAS	211310	HG0699			

JAGUAR (GB)

S TYPE

	(X200)	01.99 - 12.08			½	GAS	211089	SG2003			
					½	GAS	211090	SG2004			

X TYPE

	(X400)	01.01 - 11.09			¾	GAS	210423	MG2005			
					¾	GAS	211495	TG2006			

XJ SERIES

XJ-6 Daimler Sovereign XJ-12, Sovereign V12 Daimler Double Six XJS, XJSC		1968 - 1986			½	GAS	211494	TG2001			
		1969 - 1984									
		1972 - 02.93									
		1972 - 02.93		28	¾	GAS	211088	SG2002			
		1975 -									

JEEP (USA)

CHEROKEE

		01.76 - 12.83			oo							
					oo							
excl. Grand Cherokee	(XJ)	01.84 - 11.01			o-	GAS	211770	HG3361				
					oi	GAS	211771	HG3362				
incl. Liberty	(KJ)	09.01 - 12.07			o-	GAS	210658	MG3471				
					oo	GAS	211819	TG3472				
	(KK)	01.08 -			o-	GAS	210658	MG3471				
					oo	GAS	211819	TG3472				

GRAND CHEROKEE

Grand Cherokee excl. Up-Country sus.	(ZJ)	09.91 - 12.94			o-	GAS	211770	HG3361				
					oo	GAS	211792	HG3414				
Grand Cherokee excl. Up-Country sus.	(ZJ)	01.95 - 04.99			o-	GAS	211770	HG3361				
					oo	GAS	211792	HG3414				
Grand Cherokee excl. Up-Country sus.	(WJ, WG)	04.99 - 12.04			o-	GAS	211810	HG3456				
					oo	GAS	211811	HG3457				
Grand Cherokee	(WH, WK)	01.05 - 12.10			o-	GAS	210659	MG3473				
					oo	GAS	211820	TG3474				

COMANCHE

4X2	(MJ)	-1986			o-	GAS	211770	HG3361				
					oo							
4X4	(MJ)	1986 - 1987 - 1992			o-	GAS	211770	HG3361				
					oo	GAS	211625	HG2702				

COMPASS

	(MK49)	08.06 -			o-	GAS	210664	MG3485	MG3486			516004
					o-	GAS	211156	SG3487				

PATRIOT

	(MK74)	01.08 -			o-	GAS	210664	MG3485	MG3486			516004
					o-	GAS	211156	SG3487				

RENEGADE

excl. 4WD	(BU)	07.14 -		13A	o-	GAS	210888	MG5331	MG5330	600840		516004
				13A	o-	GAS	210889	MG5333	MG5332	600851	600852	516004
4WD excl. Trailhawk	(BU)	07.14 -		13B	o-	GAS	210890	MG5335	MG5334	600840		516004
				13B	o-	GAS	210891	MG5337	MG5336	600851	600852	516004

WAGONEER

		1976 - 1983			oo							
					oo							
(XJ) excl. Grand Wagoneer	(XJ)	1984 - 1995			o-	GAS	211770	HG3361				
					oi	GAS	211771	HG3362				
Grand Wagoneer (SJ)	(SJ)	1984 - 1990			oo							
					oo							

JEEP (USA)

WRANGLER/LAREDO

Wrangler, Laredo (YJ)	(YJ)	1987 - 1995			½	GAS	211768	HG3359			
					ø	GAS	211769	HG3360			
Wrangler, Laredo (TJ)	(YJ)	1996 - 1997			½	GAS	211770	HG3361			
					ø						

KIA (KO)

BESTA

	(TB)	02.96 -			±	GAS	212026	TG5527			
							∞	GAS	212027	TG5528	

CARENS

	(FC)	11.00 - 10.02			∞	GAS	210899	MG5529	MG5530			516004
							∞	GAS	210900	MG5531	MG5532	
	(UN)	09.06 -			∞	GAS	210910	MG5561	MG5560			516004
							±	GAS	212034	TG5562		

CARNIVAL/SEDONA

	(UP, GQ)	08.99 - 05.06			∞	GAS	210893	MG5507	MG5508			516004
							±	GAS	212028	TG5533		
	(VQ)	06.06 -			∞	GAS	210909	MG5557	MG5558			516004
							∞	GAS	212033	TG5559		

CEE'D

	(ED)	12.06 - 12.12			∞	GAS	210913	MG5569	MG5570			516004
							±	GAS	211484	TG1774		
excl. Sportwagon	(JD)	05.12 -			∞	GAS	212107	MG1791	MG1792			516004
							±	GAS	211484	TG1774		
Sportwagon	(JD)	09.12 -			∞	GAS	212107	MG1791	MG1792			516004
							±	GAS	211484	TG1774		

CERATO

	(LD)	03.04 -			∞	GAS	210914	MG5571	MG5572			516004
							∞	GAS	210915	MG5573	MG5574	

CLARUS/CREDOS

	(K9A)	07.96 - 11.01			∞	GAS	210901	MG5535	MG5534			516004
	(GC)	05.98 -					∞	GAS	210902	MG5537	MG5536	

JOICE

	(M300E)	02.00 -			∞	GAS	210522	MG2620				
							±	GAS	211600	TG2621		

MAGENTIS

	(GD)	02.01 - 12.05			∞	GAS	211081	SG1761				
							∞	GAS	211084	SG1764		
	(MG)	11.05 -			∞	GAS	210910	MG5561	MG5560			
							±	GAS	212034	TG5562		

PICANTO

	(BA)	04.04 -			∞	GAS	210903	MG5539	MG5538			516004
							±	GAS	212029	TG5540		

PICANTO II

	(TA)	05.11 -			∞	GAS	210917	MG5581	MG5582			516004
							±	GAS	212038	TG5576		

KIA (KO)

PREGIO

	(TB)	10.97 -				GAS	210906	MG5551	MG5550			516010
						GAS	212030	TG5542				516010

PRIDE

	(DA)	10.96 -12.11				OIL	200494	M 2499	M 2498			516004
						GAS	211094	SG2426				516010

PRO CEE'D

	(ED)	02.08 - 09.12				GAS	210913	MG5569	MG5570			516004
						GAS	211484	TG1774				
	(JD)	03.13 -				GAS	212107	MG1791	MG1792			516004
						GAS	211484	TG1774				

RIO

	(DC)	08.00 - 07.02				GAS	210896	MG5515	MG5516			516004
						GAS	212025	TG5517				
	(DC)	07.02 - 05.05				GAS	210911	MG5563	MG5564			516004
						GAS	212035	TG5565				

RIO II

	(JB)	03.05 -				GAS	210912	MG5567	MG5566			516004
						GAS	212036	TG5568				516010

RIO III

	(UB)	09.11 -				GAS	210918	MG5583	MG5584			516004
						GAS	211487	TG1780				

SEPHIA

	(FA)	09.93 - 12.97				OIL	200897	M 5523	M 5524			
						OIL	200898	M 5525	M 5526			

SHUMA

	(FB)	10.97 - 12.98				GAS	210894	MG5511	MG5512			
						GAS	210895	MG5513	MG5514			
	(FB)	01.99 - 04.01				GAS	210899	MG5529	MG5530			
						GAS	210895	MG5513	MG5514			
	(FB)	05.01 - 05.04				GAS	210904	MG5543	MG5544			
						GAS	210905	MG5545	MG5546			

SORENTO

	(JC)	08.02 - 11.06				GAS	211212	SG5547	SG5548			
						GAS	212031	TG5549				
	(JC)	12.06 -				GAS	211212	SG5547	SG5548			
						GAS	212037	TG5575				

SORENTO II

	(XM)	11.09 - 09.12				GAS	210413	MG1767	MG1768			516004
						GAS	211481	TG1769				

KIA (KO)

SPORTAGE

	(K00)	09.94 - 12.98			GAS	211210	SG5506			
					GAS	212024	HG5505			
	(K00)	01.99 - 08.04			GAS	210906	MG5551	MG5550		
					GAS	212032	TG5552			
	(JE)	10.04 -			GAS	210907	MG5553	MG5554		
					GAS	210908	MG5555	MG5556	600261	600262
excl. AWD	(SL)	07.10 - 12.15			GAS	210916	MG5577	MG5578		
					GAS	212039	TG5579			
AWD	(SL)	07.10 - 12.15			GAS	210916	MG5577	MG5578		516004
					GAS	212040	TG5580			516010

LADA (RU)

110/111/112

	(2110, 2111, 2112)	01.95 - 03.04			/	GAS	210027	CG2107			
					/	GAS	211092	SG2108			
	(2110, 2111, 2112)	03.04 -			/						
					/	GAS	211092	SG2108			

DIVA, FORMA, SAGONA

	(2109, 21099)	09.87 - 12.06			/	OIL	200026	C 2103			
					/	OIL	201091	S 2104			

KALINKA/NOVA

	(2104, 2105, 2108, 2109)	05.81 -			∅	OIL	201496	T 2101			
					∅	OIL	201497	T 2102			

NIVA

	(2121)	12.76 -			∅	GAS	211498	HG2105			
					∅	GAS	211499	HG2106			

NIVA II

	(2123)	09.02 -			∅						
					∅						

SAMARA/NATACHA

	(2108, 2109)	01.86 -			/	OIL	200026	C 2103			
					/	OIL	201091	S 2104			
	(2108, 2109)	01.03 -			/						
					/	OIL	201091	S 2104			

VAZ

	1.2, 1.3, 1.5, 1.6	(210-2-3-4-5-6-7, 21011, 21061)	01.70 -			∅	OIL	201496	T 2101		
						∅	OIL	201497	T 2102		

LANCIA (I)

A 112 (AUTOBIANCHI)

		03.78 - 12.86				OIL	200133	M 0503			516004
							OIL	200134	M 0504		

DEDRA

excl. 4X4	(835)	01.89 - 12.97				GAS	210259	MG1339	600751	600752	516004
							GAS	211404	TG1375		
excl. 4X4	(835)	01.98 - 07.99				GAS	210281	MG1394	600690		516004
							GAS	211404	TG1375		
4X4	(835)	09.94 - 12.97				GAS	210259	MG1339	600751	600752	516004
4X4	(835)	01.98 - 07.99				GAS	210281	MG1394	600690		516004

DELTA I

1.3, 1.5	(831ABO)	09.79 - 02.83				GAS	210424	MG2201			516004
							GAS	210426	MG2203	MG2204	
1.3, 1.5 1.6 GT, 1.6 HF Turbo	(831ABO)	02.83 - 01.86 02.83 - 01.86				GAS	210424	MG2201			516004
							GAS	210426	MG2203	MG2204	
1.3, 1.5, 1.9 D, 1.9 TD excl. 4X4 1.6, 1.6 GTie, 1.6 HF Turbo excl. 4X4	(831ABO)	02.86 - 01.94 02.86 - 01.94				GAS	210425	MG2202			516004
							GAS	210427	MG2205	MG2206	
2.0 HF 8V Integrale 4X4 2.0 HF 16V Integrale 4X4	(831ABO)	02.86 - 01.94 1987 - 01.94				GAS	210428	MG2212			516004
							GAS	210429	MG2213		
2.0 HF Integrale Evoluzione	(831ABO)	1987 -				GAS	210430	MG2214			516004
							GAS	210431	MG2215		

DELTA II

1.4, 1.6	(836)	06.93 - 08.99				GAS	210441	MG2232	600751	600752	516004
							GAS	211391	TG1340		
1.8, 2.0 16V	(836)	06.93 - 08.99				GAS	210259	MG1339	600751	600752	516004
							GAS	211404	TG1375		
1.9 TD	(836)	10.94 - 08.99				GAS	210441	MG2232	600751	600752	516004
							GAS	211404	TG1375		
2.0 Turbo 16V excl. 15	(836)	06.93 - 08.99				GAS	210432	MG2218	600751	600752	516004
							GAS	211404	TG1375		

DELTA III

excl. 1.9 D Multijet	(844)	09.08 - 08.14		13A		GAS	210163	MG0660	600560		516004
							GAS	211298	TG0662		
1.9 D Multijet	(844)	09.08 - 08.14		13B		GAS	210175	MG0690	600560		516004
							GAS	211298	TG0662		

FLAVIA

		1962 - 1970				GAS	211508	TG2252			
							GAS	211509	TG2253		

FULVIA

		1963 - 1970				GAS	211506	TG2250			516004
							GAS	211507	TG2251		

LANCIA (I)

		1963 - 1971			♂	GAS	211506	TG2250			516004
					♀	GAS	211507	TG2251			
		1961 - 1975			♀	GAS	211508	TG2252			
					♀	GAS	211509	TG2253			

KAPPA

	2.0, 3.0 V6, 2.4 TDS, 2.4 JTD > Ch. 2050295	(838A)	10.94 - 10.01			♂	GAS	210433	MG2220			516004
						♂	GAS	210435	MG2222			516004
	2.0, 3.0, 2.4 TD, 2.4 JTD Ch. 2050296 > 2087505	(838A)	10.94 - 10.01			♂	GAS	210434	MG2221			516004
						♂	GAS	210435	MG2222			516004
	2.0, 3.0 V6, 2.4 TDS, 2.4 JTD Ch. 2087506 >	(838A)	10.94 - 10.01			♂	GAS	210434	MG2221			516004
						♂	GAS	210444	MG2237			516004
	2.4, 2.0 Turbo > Ch. 2087505	(838A)	10.94 - 10.01			♂	GAS	210433	MG2220			516004
						♂	GAS	210435	MG2222			516004
	2.4, 2.0 Turbo Ch. 2087506 >	(838A)	10.94 - 10.01			♂	GAS	210433	MG2220			516004
						♂	GAS	210444	MG2237			516004
	excl. ☞	(838B)	07.96 - 10.01			♂	GAS	210433	MG2220			516004
	2.0, 3.0 V6, 2.4 TDS, 2.4 JTD	(838)	07.96 - 10.01			♂	GAS	210434	MG2221			516004
						♂	GAS	210445	MG2238			516004
	2.4, 2.0 Turbo	(838)	07.96 - 10.01			♂	GAS	210433	MG2220			516004
						♂	GAS	210445	MG2238			516004

LYBRA

	1.6, 1.8 excl. ☞	(839AX)	07.99 - 10.05		13A	♂	GAS	210442	MG2234	600660		516004
						♂	GAS	211501	TG2235			516010
	2.0, 1.9 JTD, 2.4 JTD	(839AX)	07.99 - 10.05		13B	♂	GAS	210443	MG2236	600660		516004
						♂	GAS	211501	TG2235			516010
	1.6, 1.8 excl. ☞	(839BX)	07.99 - 10.05		13A	♂	GAS	210442	MG2234	600660		516004
						♂	GAS	211501	TG2235			516010
	2.0, 1.9 JTD, 2.4 JTD	(839BX)	07.99 - 10.05		13B	♂	GAS	210443	MG2236	600660		516004
						♂	GAS	211501	TG2235			516010

MUSA

1.4i	(350)	10.04 - 09.12			♂	GAS	210164	MG0663	600130		516004
					♀	GAS	211290	TG0638			
1.3 JTD, 1.9 JTD	(350)	10.04 - 09.12			♂	GAS	210153	MG0637	600130		516004
					♀	GAS	211290	TG0638			

PHEDRA

	(179)	09.02 - 11.10			♂	GAS	210447	MG2241	MG2242	600741	600742	516004
					♀	GAS	211289	TG0636				

PRISMA

	1.3, 1.5, 1.6 1.9 D, 1.9 TD	(831AB0)	02.83 - 01.86 02.83 - 01.86			♂	GAS	210424	MG2201			
						♂	GAS	210426	MG2203	MG2204		
	1.3, 1.5, 1.6 excl. 4X4 1.9 D, 1.9 TD excl. 4X4	(831AB0)	02.86 - 02.92 02.86 - 02.92			♂	GAS	210425	MG2202			
						♂	GAS	210427	MG2205	MG2206		
	2.0 8V Integrale	(831AB0)	02.86 - 02.92			♂	GAS	210428	MG2212			
						♂	GAS	210429	MG2213			

LANCIA (I)

THEMA

> Ch. 29408 excl. 3.0 V8 8.32, 15	(834)	11.84 - 10.86			GAS	210251	MG1329			516004
					GAS	210250	MG1328			516004
Ch. 29409 > excl. 3.0 V8 8.32, 15	(834)	11.86 - 07.94			GAS	210251	MG1329			516004
					GAS	210106	MG0113			516004
Ch. 29409 > excl. 3.0 V8 8.32, 15	(834)	11.86 - 07.94			GAS	210251	MG1329			516004
					GAS	210106	MG0113			516004
3.0 V6 CRD, 3.6 V6 VVT	(LX)	09.11 -			GAS	210450	MG2248			516004
					GAS	211505	TG2249			

VOYAGER

MPV, Space Wagon	(404)	09.11 - 12.14			GAS	210450	MG2248			516004
					GAS	211505	TG2249			

Y 10

4X2	(156)	03.85 - 1992			OIL	200135	M 0505	M 0506			516004
					GAS	210135	MG0505	MG0506			
					OIL	201714	T 0507				
					GAS	211714					
4X2	(156)	1933 - 1996			OIL	200135	M 0505	M 0506			516004
					GAS	210135	MG0505	MG0506			
					OIL	201276	T 0509				
					GAS	211276	TG0509				
4X4	(156)	03.85 - 1992			OIL	200135	M 0505	M 0506			516004
					GAS	210135	MG0505	MG0506			
					OIL	201275	T 0508				
					GAS	211275	TG0508				
4X4	(156)	1933 - 1996			OIL	200135	M 0505	M 0506			516004
					GAS	210135	MG0505	MG0506			
					GAS	211277	TG0510				

Y

excl. Elefantino Blu	(840A)	11.95 - 09.03			GAS	210436	MG2223	600520	516004
					GAS	211397	TG1351		
Elefantino Blu	(840A)	11.95 - 09.03			GAS	210262	MG1350	600520	516004
					GAS	211397	TG1351		

YPSILON

	(843)	10.03 - 12.11			GAS	210164	MG0663	600130	516004
					GAS	211290	TG0638		

YPSILON II





	(312)	05.11 -			GAS	210449	MG2245	MG2246	600500	516004
					GAS	211504	TG2247			

ZETA

(> Ch. 7609)	(834)	03.94 - 12.97			GAS	210270	MG1366	600741	600742	516004
				18A		GAS	211401	TG1367		



LANCIA (I)

 (Ch. 7610 >)	(834)	01.98 - 09.02				GAS	210270	MG1366	600741	600742	516004
				18B		GAS	211351	TG0944			

LAND ROVER (GB)

88/109 SERIES

x= 86" x= 88" I, II, IIA, IIB, III series x= 107" x= 109" I series		01.53 - 06.56			⊕	GAS	211510	HG2301			
		01.56 - 12.83			⊖						
x= 109" II, IIA, IIB, III series x= 119"		01.53 - 11.58			⊕	GAS	211248	HG0201			
		01.53 - 02.58			⊖						
x= 109" II, IIA, IIB, III series x= 119"		01.58 - 12.84			⊕	GAS	211510	HG2301			
		01.58 - 12.84			⊖						

90/110 SERIES

		09.83 - 07.90			+	GAS	211512	HG2304			
					♀	GAS	211513	HG2305			

DEFENDER

	(LD)	09.90 -			+	GAS	211512	HG2304			
					♀	GAS	211513	HG2305			

DISCOVERY I

> Ch. MA135957		09.89 - 06.94			+	GAS	211512	HG2304			
					♀	GAS	211515	HG2307			

DISCOVERY II

Ch. MA135958 >	(LJ, LT)	06.94 - 12.98			+	GAS	211512	HG2304			
					♀	GAS	211516	HG2309			

DISCOVERY III

excl. □, Active roll	(LJ, LT)	11.98 - 06.04			⊕	GAS	211520	TG2317			
					⊖	GAS	211521	TG2318			
□ excl. Active roll	(LJ, LT)	11.98 - 06.04			⊕	GAS	211520	TG2317			
					⊖	GAS	211522	TG2319			

FREELANDER

	(LN)	02.98 - 10.00			⊕	GAS	210451	MG2313	MG2314		
					⊖	GAS	210452	MG2315	MG2316		
	(LN)	10.00 - 10.06			⊕	GAS	210453	MG2321	MG2320		
					⊖	GAS	210452	MG2315	MG2316		

FREELANDER II

excl. □, ♯	(LF_ FA_)	10.06 - 10.14			⊕	GAS	210454	MG2323	MG2322		
					⊖	GAS	210455	MG2325	MG2324		

RANGE ROVER

x= 100" excl. □	(LH)	06.70 - 07.94			+	GAS	211512	HG2304			
					♀	GAS	211515	HG2307			
□	(LH)	10.92 - 07.94			+	GAS	211517	HG2310			
					♀	GAS	211516	HG2309			
Classic excl. □	(LH)	07.94 - 02.96			+	GAS	211512	HG2304			
					♀	GAS	211515	HG2307			
Classic □	(LH)	07.94 - 02.96			+	GAS	211517	HG2310			
					♀	GAS	211516	HG2309			

LAND ROVER (GB)

□ excl. Classic	(LP)	09.94 - 03.02			♀	GAS	211518	HG2311			
					♀	GAS	211519	HG2312			
	(LM)	03.02 - 08.12									
					♂						
Sport	(L320)	02.05 - 03.13									

SANTANA

x= 88" 2.5 DC, 2500 DC		01.58 - 12.89			♀	GAS	211510	HG2301			
					♀	GAS	211248	HG0201			
x= 109", 119" 2.5DL/DE, 3.5DL, 2500DL, 3500DL		01.58 - 12.89			♀	GAS	211510	HG2301			
					♀	GAS	211511	HG2303			

MAZDA (J)

121/REVUE I

	(DA)	10.87 - 02.91				OIL	200494	M 2499	M 2498			516004
						GAS	211094	SG2426				

121/REVUE II

	(DB)	03.91 - 03.96				GAS	210468	MG2427			516004
						GAS	211095	SG2428			

121/REVUE III

	1.25, 1.3 16V, 1.4 16V	(JASM, JBSM)	08.95 - 09.98				GAS	210313	MG1476	600310	516004
					21D		GAS	211054	SG1477	600360	
	1.25, 1.3 16V	(JASM, JBSM)	10.98 - 04.03				GAS	210313	MG1476	600310	516004
					21E		GAS	211057	SG1507	600360	
	1.4 16V	(JASM, JBSM)	10.98 - 04.03				GAS	210313	MG1476	600310	516004
					21D		GAS	211054	SG1477	600360	
	1.8 D	(JASM, JBSM)	08.95 - 09.98				GAS	210316	MG1482	600310	516004
					21D		GAS	211054	SG1477	600360	
	1.8 D	(JASM, JBSM)	10.98 - 04.03				GAS	210316	MG1482	600310	516004
					21E		GAS	211057	SG1507	600360	

2

	(DY)	01.03 - 12.03		22A		GAS	210330	MG1517	MG1516	600340	516004
						GAS	211442	TG1515		600460	516010
	(DY)	01.04 - 12.09		22B		GAS	210487	MG2473	MG2474	600340	516004
						GAS	211442	TG1515		600460	516010

2 II

	(DE)	10.07 - 06.15				GAS	210965	MG6309	MG6310		516004
						GAS	212081	TG6311			516010

3

	1.6, 2.0	(BK)	10.03 - 06.09				GAS	210488	MG2477	MG2476	600480	516004
							GAS	211528	TG2475		600400	516010

3 II

	(BL)	06.09 -				GAS	210488	MG2477	MG2476	600480	516004
						GAS	211528	TG2475		600400	516010

3 III

	(BM, BN)	09.13 -				GAS	212108	MG6315	MG6316		516004
						GAS	212109	TG6317			516010

323 II

	1.1, 1.3, 1.5	(BD)	06.80 - 10.89				GAS	210456	MG2403		516004
							GAS	210457	MG2404		516004

323 III

	1.1, 1.3, 1.4, 1.5, 1.6, 1.7 D excl. 4X4, 4x4	(BF)	01.85 - 05.89				GAS	210456	MG2403		516004
							GAS	210457	MG2404		516004

MAZDA (J)

excl. 4X4,	(BW12)	11.85 - 10.95				GAS	210456	MG2403			516004
------------	--------	---------------	--	--	--	-----	--------	--------	--	--	--------

323 IV

323 C, 323 S excl. 4X4,	(BF)	06.89 - 08.94				GAS	210458	MG2405	MG2406		516004
						GAS	210459	MG2407	MG2408		516004
323 F 1.6, 1.8 excl. 4X4,	(BG)	06.89 - 08.94				GAS	210458	MG2405	MG2406		516004
						GAS	210459	MG2407	MG2408		516004

323 V

1.3, 1.5, 1.7 TD, 1.8, 2.0 D 323 F 1.3, 1.5, 1.8	(BA)	09.94 - 09.98				GAS	210471	MG2439	MG2440		516004
	(BA)	09.94 - 09.98				GAS	210472	MG2441	MG2442		516004

323 VI

1.3, 1.5, 1.8, 2.0 D, 2.0 TD > Ch. 304194	(BJ)	09.98 - 12.99				GAS	210481	MG2461	MG2462		516004
						GAS	210482	MG2463	MG2464		516004
1.3, 1.5, 1.8, 2.0 D, 2.0 TD Ch. 304195 > 400000	(BJ)	01.00 - 11.00				GAS	210483	MG2465	MG2466		516004
						GAS	210482	MG2463	MG2464		516004
1.3, 1.5, 1.8, 2.0 D, 2.0 TD Ch. 400001 >	(BJ)	12.00 - 05.04				GAS	210483	MG2465	MG2466		516004
						GAS	210484	MG2467	MG2468		516004

5

	(CR)	03.05 - 05.10				GAS	210489	MG2485	MG2484	600480	516004
						GAS	211531	TG2486		600400	516010

5 II

	(CW)	09.10 -				GAS	210489	MG2485	MG2484	600480	516004
						GAS	211531	TG2486		600400	516010

6

excl.	(GG)	06.02 - 12.08				GAS	211100	SG2479	SG2478		
excl. , 4X4	(GY)	08.02 - 12.07				GAS	211529	TG2480			
4X4 excl.	(GY)	06.02 - 12.07				GAS	211101	SG2481	SG2482		
4x2	(GH)	08.07 - 07.13				GAS	210963	MG6303	MG6304		
						GAS	212079	TG6307			
4x4	(GH)	08.07 - 07.13				GAS	210964	MG6305	MG6306		
						GAS	212080	TG6308			

626 II

excl.	(GC)	11.82 - 05.87				GAS	210460	MG2411			516004
						GAS	210461	MG2412			516004

626 III

, excl. 4WS,	(GD)	05.87 - 12.91				GAS	210462	MG2413			516004
						GAS	210463	MG2414			516004
excl. 4X4, , 4WS	(GV)	03.88 - 09.97				GAS	210462	MG2413			516004

MAZDA (J)

626 IV

excl. 4X4, 4WS	(GE)	08.91 - 04.97			GAS	210464	MG2415	MG2416			516004
					GAS	210465	MG2417			516004	

626 V

excl. 4X4,	(GF)	04.97 - 07.99			GAS	210475	MG2447	MG2448			516004
					GAS	210476	MG2449	MG2450			516004
excl. 4X4,	(GW)	04.97 - 07.99			GAS	210475	MG2447	MG2448			516004
					GAS	210490	MG2487	MG2488			516004
excl.	(GF)	08.99 - 10.02			GAS	210477	MG2451	MG2452			516004
					GAS	210478	MG2453	MG2454			516004
excl. 4X4,	(GW)	08.99 - 10.02			GAS	210477	MG2451	MG2452			516004
											516004

929 III

excl. 3.0 V6,	(HC)	09.86 - 05.89			GAS	210466	MG2422			516004
					GAS	211093	SG2423			
excl.	(HC)	06.89 - 06.91			GAS	210467	MG2424			516004
					GAS	211093	SG2423			

B SERIES

1.6, 1.8, 2.0	(BNA)	01.70 - 08.85				201673	T 2920			
1600, 2000, 2200 excl. 4X4	(UF)	01.85 - 06.99 01.85 - 06.99			GAS	211670	HG2916			516004
					OIL	201377	T 1303			

CX-5

excl. ALKS01	(KE, GH)	11.11 -			GAS	210966	MG6313	MG6312			516004
					GAS	212082	TG6314			516010	

DEMIO

	(DW)	08.98 - 12.99			GAS	210491	MG2489	MG2490			516004
					GAS	211102	SG2491				
	(DW)	01.00 - 12.02			GAS	210491	MG2489	MG2490			516004
					GAS	211102	SG2491				

E SERIES

E 1600		01.78 - 06.84				201673	T 2920			
E 2200		01.78 - 06.84				201673	T 2920			
E 1400, 1800	(SR1, SR2)	01.84 - 12.97								
E 2000, 2200 excl. 4X4		01.84 - 12.97								
E 1400, 1800 excl. 4X4 E 2000, 2200 excl. 4X4	(SR1, SR2)	01.84 - 12.97 01.84 - 12.97								

MAZDA (J)

MPV

excl. 4X4	(LV52, LV12)	1993 - 09.99				GAS	210469	MG2435			516004
						GAS	211526	HG2436			
4X4	(LV52, LV12)	1993 - 09.99				GAS	210469	MG2435			516004
						GAS	211526	HG2436			
excl. 4X4	(LW)	09.99 - 03.02									516004
excl. 4X4	(LW)	03.02 - 02.06									516004

MX-3

	(EC)	07.91 - 05.98									516004

MX-5/MIATA

excl. ABS	(NA)	09.89 - 04.98				GAS	211096	SG2429			
						GAS	211097	SG2430			
ABS	(NA)	09.89 - 04.98									
						GAS	211097	SG2430			
excl. ABS	(NB)	05.98 - 02.05									

MX-6

excl. 4WS,	(GE1)	07.91 - 1997				GAS	210464	MG2415	MG2416			516004
						GAS	210465	MG2417				516004
2.5 4WS excl.	(GE7)	07.91 - 1997				GAS	210464	MG2415	MG2416			516004
												516004

PREMACY

	(CP)	07.99 - 06.01				GAS	210485	MG2469	MG2470			516004
						GAS	210486	MG2471	MG2472			516004
	(CP)	07.01 - 03.05				GAS	210962	MG6301	MG6302			516004
						GAS	210486	MG2471	MG2472			516004

MERCEDES (D)

190 SERIES (W201)

excl. 2.3-16, 2.5-16, sportline	(W201)	11.82 - 08.93				GAS	210495	MG2502			516004
				excl.		GAS	211533	TG2503			
2.3-16, 2.5-16, sportline	(W201)	11.82 - 08.93				GAS	210496	MG2508			516004
				excl.		GAS	211533	TG2503			

200 SERIES (W114/115/116/123/124/126)

280 S, 280 SE, 280 SEL	(W116)	09.72 - 07.80				GAS	211536	TG2506			
				excl.		GAS	211535	TG2505			
200, 220, 230, 250	(W115)	01.68 - 01.77				GAS	211534	TG2504			
						GAS	211535	TG2505			
200 D, 220 D	(W115)	01.68 - 01.77				GAS	211534	TG2504			
						GAS	211535	TG2505			
280, 280 E, 240 D	(W114)	06.72 - 11.76				GAS	211534	TG2504			
						GAS	211535	TG2505			
220, 240 D	(W115)	01.68 - 12.79				GAS	211534	TG2504			
200, 200 D, 220, 220 D	(W123)	01.76 - 11.84				GAS	211536	TG2506			
						GAS	211535	TG2505			
230, 240 D, 250	(W123)	01.76 - 11.84				GAS	211536	TG2506			
						GAS	211535	TG2505			
280, 280 E	(W123)	01.76 - 11.84				GAS	211536	TG2506			
						GAS	211535	TG2505			
280 S, 280 SE, 280 SEL	(W126)	10.79 - 12.85				GAS	211536	TG2506			
						GAS	211535	TG2505			
200, 200 E, 230 E, 260 E excl. 4-matic, sportline	(W124)	11.84 - 06.93				GAS	210495	MG2502			516004
						GAS	211533	TG2503			
200 D, 250 D, 250 Turbo-D excl. 4-matic, sportline	(W124)	11.84 - 06.93				GAS	210496	MG2508			516004
						GAS	211533	TG2503			
sportline	(W124)	11.84 - 06.93				GAS	210496	MG2508			516004
						GAS	211533	TG2503			
260 SE	(W126)	09.85 - 06.91				GAS	211536	TG2506			
				excl.		GAS	211535	TG2505			
220, 220 D	(W115)	01.68 - 12.78				GAS	211534	TG2504			
						GAS	211535	TG2505			
230/4, 240 D	(W115)	01.73 - 12.78				GAS	211535	TG2505			
200 T, 230 T, 230 TE	(S123)	09.77 - 12.85				GAS	211536	TG2506			516004
240 T, 250 T, 280 TE	(S123)	09.77 - 12.85				GAS	211536	TG2506			
200 T, 200 TD, 230 TE excl. 4-Matic, sportline	(S124)	09.85 - 06.93				GAS	210495	MG2502			516004
250 TD, 280 TE excl. 4-Matic, sportline	(S124)	09.85 - 06.93				GAS	210495	MG2502			516004
sportline	(S124)	09.85 - 06.93				GAS	210496	MG2508			516004
250 C, 250 CE	(W114)	01.73 - 01.77				GAS	211534	TG2504			
						GAS	211535	TG2505			
280 C, 280 CE	(W115)	01.73 - 01.77				GAS	211535	TG2505			
230 C, 230 CE	(C123)	03.77 - 12.85				GAS	211536	TG2506			
						GAS	211535	TG2505			
280 C, 280 CE	(C123)	03.77 - 12.85				GAS	211536	TG2506			
						GAS	211535	TG2505			
200 CE, 220 CE, 230 CE, 280 CE excl. sportline	(C124)	03.87 - 06.93				GAS	210495	MG2502			516004
				excl.		GAS	211533	TG2503			

MERCEDES (D)

300 SERIES (W116/123/124/126)

350 SE, 350 SEL	(W116)	09.72 - 07.80			♂	GAS	211536	TG2506			
				excl. ♀	±	GAS	211535	TG2505			
300 D	(W123)	02.76 - 11.85			♂	GAS	211536	TG2506			
				excl. ♀	±	GAS	211535	TG2505			
300 SD Turbo D 380 SE, 380 SEL	(W126)	01.81 - 06.91			♂	GAS	211536	TG2506			
	(W126)	12.79 - 12.86		excl. ♀	±	GAS	211535	TG2505			
300 E, 320 E, 300 D, 300 D Turbo excl. 4-matic, sportline	(W124)	11.84 - 06.93			♀	GAS	210495	MG2502			
				excl. ♀	♂	GAS	211533	TG2503			
300 SE, 300 SEL	(W126)	09.85 - 06.91			♂	GAS	211536	TG2506			
				excl. ♀	±	GAS	211535	TG2505			
300 TD	(S123)	09.77 - 11.85			♂	GAS	211536	TG2506			
300 TE, 300 TD Turbo, 320 TE excl. 4-Matic, sportline	(S124)	09.85 - 06.93			♀	GAS	210495	MG2502			516004
sportline	(S124)	09.85 - 06.93			♀	GAS	210496	MG2508			516004
300 CE, 320 CE excl. sportline	(C124)	03.87 - 05.93			♀	GAS	210495	MG2502			516004
				excl. ♀	♂	GAS	211533	TG2503			
380 SEC	(C126)	10.81 - 07.85			♂	GAS	211536	TG2506			
				excl. ♀	±	GAS	211535	TG2505			

400 SERIES (W116/124/126)

450 SE, 450 SEL	(W116)	03.73 - 07.80			♂	GAS	211536	TG2506			
				excl. ♀	±	GAS	211535	TG2505			
400 E excl. 4-matic, sportline	(W124)	11.84 - 06.93			♀	GAS	210495	MG2502			516004
					♂	GAS	211533	TG2503			
420 SE, 420 SEL 420 SEC	(W126)	10.85 - 06.91			♂	GAS	211536	TG2506			
	(C126)	10.85 - 06.91		excl. ♀	±	GAS	211535	TG2505			

500 SERIES (W126)

500 SE, 500 SEL, 560 SEL 560 SEL	(W126)	12.79 - 06.91			♂	GAS	211536	TG2506			516004
	(W126)	09.85 - 06.91		excl. ♀	±	GAS	211535	TG2505			
500 SEC 500 SEC, 560 SEC	(C126)	10.81 - 08.85			♂	GAS	211536	TG2506			516004
	(C126)	09.85 - 06.91		excl. ♀	±	GAS	211535	TG2505			

A CLASS (W168/169/176)

140, 160, 190, 160 CDI, 170 CDI	(W168)	07.97 - 08.04			♀	GAS	210499	MG2554	600610	516004
					♂	GAS	211572	TG2553		
	(W168)	07.97 - 08.04			♀	GAS	210499	MG2554	600610	516004
					♂	GAS	211572	TG2553		
Alternativa con piattello in alluminio	(W168)	07.97 - 08.04			♀	GAS	210515	MG2590		516004
					♂	GAS	211572	TG2553		
	(W169)	09.04 - 06.12			♀	GAS	210501	MG2557	600550	516004
					♂	GAS	211574	TG2558		
Alternativa monotubo al posteriore	(W169)	09.04 - 06.12			♀	GAS	210501	MG2557	600550	516004
					♂	GAS	211590	TG2591		
150, 170, 200, 160 CDI, 180 CDI, 200 CDI	(W169)	09.04 - 06.12			♀	GAS	210501	MG2557	600550	516004
					♂	GAS	211574	TG2558		

MERCEDES (D)

180, 200, 180 CDI, 200 CDI, 220 CDI excl. 4-matic	(W176)	06.12 -				GAS	210512	MG2583	MG2584			516004
						GAS	211587	TG2585				516010

B CLASS (W245/246)

150, 170, 200, 200 Turbo, 180 CDI, 200 CDI	(W245)	03.05 - 11.11				GAS	210501	MG2557		600550	516004
						GAS	211574	TG2558			
	(W245)	03.05 - 11.11				GAS	210501	MG2557		600550	516004
						GAS	211574	TG2558			
Alternativa monotubo al posteriore	(W245)	03.05 - 11.11				GAS	210501	MG2557		600550	516004
						GAS	211590	TG2591			
180, 200, 180 CDI, 200 CDI, 220 CDI excl. 4-matic	(W246)	11.11 -				GAS	210512	MG2583	MG2584		516004
						GAS	211587	TG2585			516010

C CLASS (W202/203)

C 180, 200, 220, 230, 240 excl. Esprit, AMG,	(W202, S202)	05.93 - 03.01 05.93 - 03.01				GAS	211538	TG2510			
				excl.		GAS	211539	TG2511			
C 200 D, 220 D, 250 D excl. Esprit, AMG,	(W202, S202)	05.93 - 03.01 05.93 - 03.01				GAS	211538	TG2510			
				excl.		GAS	211539	TG2511			
C 180, 200, 220, 230, 240 excl. Esprit, AMG,	(W202, S202)	05.93 - 03.01 05.93 - 03.01				GAS	211569	TG2547			
				excl.		GAS	211539	TG2511			
C 200 D, 220 D, 250 D excl. Esprit, AMG,	(W202, S202)	05.93 - 03.01 05.93 - 03.01				GAS	211569	TG2547			
				excl.		GAS	211539	TG2511			
C250 TD, C280 excl. Esprit, AMG,	(W202, S202)	05.93 - 03.01				GAS	211569	TG2547			
						GAS	211570	TG2548			
Esprit, sportline excl. AMG	(W202, S202)	05.93 - 03.01				GAS	211556	TG2533			
						GAS	211557	TG2534			
	(W203)	05.00 - 02.07				GAS	210502	MG2559			
						GAS	211575	TG2560			
T-Model	(S203)	03.01 - 08.07				GAS	210502	MG2559			
						GAS	211575	TG2560			
Sportcoupé	(CL203)	03.01 - 06.11				GAS	210502	MG2559			
						GAS	211575	TG2560			

C CLASS (W204/S204)

excl. 4-matic, AMG,	(W204)	01.07 - 01.14				GAS	210506	MG2571			
						GAS	211582	TG2572			
T-Model excl. 4-matic, AMG,	(S204)	08.07 - 08.14				GAS	210506	MG2571			
						GAS	211582	TG2572			
excl. 4-matic, AMG,	(C204)	06.11 -				GAS	210506	MG2571			
						GAS	211582	TG2572			
4-matic	(W204-S204)	07.07 - 08.14				GAS	210511	MG2582			
						GAS	211582	TG2572			

CITAN

	(415)	11.12 -				GAS	210669	MG3496			516004
						GAS	211827	TG3489			

CL (C140)

200, 230, 320	(C140)	09.92 - 02.99				GAS	211568	TG2545			
						GAS	212093	TG2546			

MERCEDES (D)

CLA

excl. 4-matic, AMG	(C117)	01.13 -				GAS	210512	MG2583	MG2584			516004
							GAS	211587	TG2585			
Shooting Brake excl. 4-matic, AMG	(X117)	01.15 -				GAS	210512	MG2583	MG2584			516004
							GAS	211587	TG2585			

CLC

	(203)	05.08 - 06.11				GAS	210502	MG2559				516004
							GAS	211575	TG2560			

CLK (A-C208/209)

200, 200 K, 230, 230 K, 320	(A208, C208)	06.97 - 06.02				GAS	211558	TG2535				
							GAS	211559	TG2536			
200, 200 CGI, 240, 320, 500 excl. sportline	(C209)	06.02 - 05.09				GAS	210502	MG2559				
			200 K, 270 Cdi excl. sportline	(A209)	02.03 - 03.10						GAS	211575

CLS

	(C219)	10.04 - 12.10				GAS	211106	SG2573				
							GAS	211583	TG2574			

E CLASS (W124/210)

E 200, 220, 280, 320, 420 E 200 D, 250 D, 250 D Turbo, E 300 D, E 350 D Turbo excl. sportline, 4-Matic	(W124)	06.93 - 06.95				GAS	210495	MG2502				516004
							GAS	211533	TG2503			
E 280, E 250 D long	(W124)	06.93 - 06.95				GAS	210495	MG2502				516004
E 500	(W124)	06.93 - 06.95				GAS	210495	MG2502				516004
sportline	(W124)	06.93 - 06.95				GAS	210496	MG2508				516004
							GAS	211533	TG2503			
E 200 T, 220 T, 280 T, 320 E 250 TD, 300 TD, 300 T TD excl. sportline, 4-Matic	(S124)	06.93 - 06.96				GAS	210495	MG2502				516004
sportline	(S124)	06.93 - 06.96				GAS	210496	MG2508				516004
E 200 C, E 220 C, E 320 C excl. sportline	(C124)	06.93 - 06.97				GAS	210495	MG2502				516004
							GAS	211533	TG2503			
sportline	(C124)	06.93 - 06.97				GAS	210496	MG2508				516004
							GAS	211533	TG2503			
E 220, E 320 excl. sportline	(A124)	06.93 - 03.98										516004
							GAS	211533	TG2503			
sportline	(A124)	06.93 - 03.98										
							GAS	211533	TG2503			
E 200, E 220 D excl. sportline, v6	(W210)	05.95 - 03.02										
						excl. v6	GAS	211560	TG2537			
E 230, E 250 D excl. sportline, v6	(W210)	05.95 - 03.02										
						excl. v6	GAS	211561	TG2538			

MERCEDES (D)

E 280, E 280 TD, E 290 TD excl.	(W210)	05.95 - 03.02				GAS	211560	TG2537			
E 300 D, E 320, E 420 excl.	(W210)	05.95 - 03.02		excl.		GAS	211561	TG2538			
excl.	(S210)	05.95 - 03.03				GAS	211560	TG2537			
Avantgarde excl 4-Matic, AMG,	(W210)	05.95 - 03.02				GAS	211578	TG2566			
Avantgarde excl 4-Matic, AMG,	(W210)	05.95 - 03.02				GAS	211579	TG2567			
Avantgarde excl 4-Matic, AMG,	(S210, T210)	05.95 - 03.02				GAS	211578	TG2566			

E CLASS (W211/S211)

excl.	(W211)	03.02 - 12.08				GAS	211105	SG2561			
excl.	(W211)	03.02 - 12.08				GAS	211576	TG2562			
excl.	(S211)	03.03 - 07.09				GAS	211105	SG2561			
excl.	(S211)	03.03 - 07.09				GAS	211577	TG2563			

E CLASS (W212/S212)

excl. 4-matic, AMG,	(W212)	01.09 -				GAS	210513	MG2586			
excl. 4-matic, AMG,	(W212)	01.09 -				GAS	211588	TG2587			
T-Model excl. 4-matic, AMG,	(S212)	11.09 -				GAS	210513	MG2586			
T-Model excl. 4-matic, AMG,	(S212)	11.09 -				GAS	211589	TG2589			
4-matic excl. AMG,	(W212)	01.09 -				GAS	210514	MG2588			
4-matic excl. AMG,	(W212)	01.09 -				GAS	211588	TG2587			
4-matic excl. AMG,	(S212)	11.09 -				GAS	210514	MG2588			
4-matic excl. AMG,	(S212)	11.09 -				GAS	211589	TG2589			

E CLASS (A207/C207)

	(A207)	01.10 -				GAS	210516	MG2592			
	(A207)	01.10 -				GAS	211591	TG2593			
	(C207)	01.09 -				GAS	210516	MG2592			
	(C207)	01.09 -				GAS	211591	TG2593			

G CLASS (W460/463)

230 G, 230 GE, 240 GD	(W460)	02.79 - 08.93				GAS	211540	HG2512			
250 GD, 280 GE, 300 GD	(W460)	02.79 - 08.93				GAS	211541	HG2513			
230 GE, 300 GE, 250 GD	(W463)	09.89 -				GAS	211542	HG2514			
300 GD, 350 GD	(W463)	09.89 -				GAS	211543	HG2515			
230 G, 230 GE, 240 GD	(W461)	09.93 -				GAS	211540	HG2512			
250 GD, 280 GE, 300 GD	(W461)	09.93 -				GAS	211541	HG2513			

GLA

excl. 4-matic, AMG	(X156)	12.13 -				GAS	210517	MG2595	MG2594		
excl. 4-matic, AMG	(X156)	12.13 -				GAS	211592	TG2596			

MB SERIES

90, 100, 120 (made in Spain)	(631)	05.84 - 02.96				OIL	201544	H 2519			
90, 100, 120 (made in Spain)	(631)	05.84 - 02.96				OIL	201545	H 2520			
140, 160, 180 (made in Spain)	(631)	05.84 - 02.96				OIL	201546	H 2521			
140, 160, 180 (made in Spain)	(631)	05.84 - 02.96				OIL	201547	H 2522			

MERCEDES (D)

ML SERIES (W163)

ML 320	(W163)	02.98 - 06.05			⊖	GAS	211571	TG2549			
					⊕	GAS	211104	SG2550			

ML SERIES (W164)

ML 280, 300, 320, 350	(W164)	07.05 - 12.11			⊕						
					⊖						

S CLASS (W140)

excl. S 600,	(W140, C140)	02.91 - 02.99			⊖	GAS	211553	TG2529			
				excl.	⊖	GAS	211554	TG2530			

SL SLC SERIES (C107/R107/R129)

380 SL, 500 SL	(R107, C107)	09.80 - 12.85			+	GAS	211534	TG2504			
				excl.	±	GAS	211535	TG2505			
300 SL, 420 SL, 500 SL	(R107, C107)	09.85 - 08.89			+	GAS	211534	TG2504			
				excl.	±	GAS	211535	TG2505			
280 SL, 300 SL	(R107, C107)	05.71 - 08.89			+	GAS	211534	TG2504			
				excl.	±	GAS	211535	TG2505			
350 SL, 380 SL, 450 SL	(R107, C107)	05.71 - 08.89			+	GAS	211534	TG2504			
				excl.	±	GAS	211535	TG2505			
300 SL, 500 SL > Ch. F054767	(R129)	03.89 - 1993			⊕						
					⊖						
SL 280, SL 320, SL 500 Ch. F054768 >	(R129)	1993 - 10.01			⊕						
					⊖						

SLK (R170)

200, 230 K, 320 excl. AMG	(R170)	09.96 - 04.04			⊖	GAS	211563	TG2540			
					⊖	GAS	211564	TG2541			

SLK (R171)

	(R171)	04.04 - 02.11			⊕	GAS	210505	MG2568			
					⊖	GAS	211580	TG2569			

SPRINTER

200 series	(901, 902, 903)	01.95 - 05.06			⊕	GAS	210497	MG2551			516007
					⊖	GAS	211565	TG2542			
300 series	(901, 902, 903)	01.95 - 05.06			⊕	GAS	210498	MG2552			516007
					⊖	OIL	201566	H 2543			

SPRINTER II

200, 300 Series excl H.D. excl.	(906)	06.06 -			⊕	GAS	210507	MG2575	600220	516007
					⊖	GAS	211584	HG2576		
200 Series incl H.D.	(906)	06.06 -			⊕	GAS	210509	MG2579	600220	516007
					⊖					
300 Series incl H.D. incl.	(906)	06.06 -			⊕	GAS	210507	MG2575	600220	516007
					⊖					
400 Series incl H.D. excl.	(906)	06.06 -			⊕	GAS	210509	MG2579	600220	516007
					⊖	GAS	211586	HG2580		
400 Series incl.	(906)	06.06 -			⊕	GAS	210509	MG2579	600220	516007
					⊖					
4x4	(906)	02.06 -			⊕	GAS	210510	MG2581	600220	516007
					⊖					

MERCEDES (D)

V CLASS

excl.	(638)	02.96 - 07.03				GAS	210500	MG2555			516004
						GAS	211567	TG2544			

VANEO

1.6, 1.9, 1.7 CDi	(414)	02.02 - 07.05				GAS	210508	MG2577			516004
						GAS	211585	TG2578			

VIANO

excl.	(639)	09.03 -				GAS	210504	MG2565			516004
				29A		GAS	211573	TG2556			
				29B		GAS	211581	TG2570			

VITO I

excl.	(638)	02.96 - 10.03				GAS	210500	MG2555			516004
						GAS	211567	TG2544			

VITO II

excl.	(639)	09.03 -				GAS	210504	MG2565			516007
				29A		GAS	211573	TG2556			
				29B		GAS	211581	TG2570			

O 300 SERIES

O 309 B, O 309 D, O 319 B, O 319 D		01.68 -		30C		OIL	201550	T 2526			
				30C		OIL	201550	T 2526			

O 400 SERIES

O 406, O 407		01.68 -		30C		OIL	201550	T 2526			
				30C		OIL	201550	T 2526			

O 500 SERIES

O 508 D		01.68 -		30D		OIL	201551	T 2527			
				30D		OIL	201551	T 2527			

L 200 SERIES

L 207 D, L 208, L 208 D, L 209 D/DE, L 210, L 210 C/D	(601)	01.78 - 02.96		30A		OIL	201548	T 2524			
		10.88 - 02.96		30B		OIL	201549	T 2525			

L 300 SERIES

L 307, L 307 D, L 308, L 309 D/DC L 310, L 310 C/D	(602)	10.82 - 02.96		30A		OIL	201548	T 2524			
		06.89 - 02.96		30B		OIL	201549	T 2525			
L 319, L 319 B/D, L393		01.61 - 02.96		30C		OIL	201550	T 2526			
				30C		OIL	201550	T 2526			

L 400 SERIES

L 405, L 406, L 407, L 408, L 409, L 410		10.61 - 02.96		30C		OIL	201550	T 2526			
				30C		OIL	201550	T 2526			
L 405, L 406, L 407, L 408, L 409, L 410		10.61 - 02.96		30D		OIL	201551	T 2527			
				30D		OIL	201551	T 2527			

MERCEDES (D)

L 500 SERIES

L 508, L 508 DG, LF 508 D, LK 508 DG, LKO 508 DG		01.61 - 02.96		30D	⊗	OIL	201551	T 2527			
		01.72 - 02.96		30D	⊗	OIL	201551	T 2527			

L 600 SERIES

L 608, L 608 D, L 608 DG, LF 608 D, LK 608 D, L 613, L 613 D		01.70 - 02.96		30D	⊗	OIL	201551	T 2527			
				30D	⊗	OIL	201551	T 2527			

MINI (GB)

CABRIOLET

excl.	(F57)	11.15 -				GAS	210950	MG6145	MG6146			516004
						GAS	212068	TG6137				

COUNTRYMAN

excl.	(R60)	06.10 -				GAS	210948	MG6139	MG6138			516004
						GAS	211229	SG6141	SG6140			

MINI

One, One D, Cooper incl. excl. Cooper S	(R50, R53)	06.01 - 03.02										516004
						GAS	211033	SG0855				
One, One D, Cooper excl. Cooper S Sport Plus	(R50, R53)	03.02 - 09.06				GAS	210187	MG0853	MG0854	600410		516004
						GAS	211033	SG0855				
Cooper S incl. Sport Plus	(R50, R53)	03.02 - 09.06				GAS	210188	MG0857	MG0858	600410		516004
						GAS	211034	SG0856				
One, Cooper, Cooper S	(R50, R53)	07.04 - 09.06				GAS	210188	MG0857	MG0858	600410		516004
						GAS	211034	SG0856				
	(R56)	10.06 - 11.13				GAS	210941	MG6109	MG6110			516004
						GAS	211220	SG6111	SG6112			
Clubmann	(R55)	10.07 - 06.14				GAS	210941	MG6109	MG6110			516004
						GAS	211220	SG6111	SG6112			
Cabriolet	(R57)	11.07 - 06.15				GAS	210941	MG6109	MG6110			516004
						GAS	211220	SG6111	SG6112			
Coupè	(R58)	09.11 - 05.15				GAS	210941	MG6109	MG6110			516004
						GAS	211220	SG6111	SG6112			
excl.	(F56)	12.13 -				GAS	210950	MG6145	MG6146			516004
						GAS	212068	TG6137				
excl.	(F55)	07.14 -				GAS	210950	MG6145	MG6146			516004
						GAS	212068	TG6137				

PACEMAN

excl.	(R61)	04.12 -				GAS	210948	MG6139	MG6138			516004
						GAS	211229	SG6141	SG6140			

ROADSTER

excl.	(R59)	02.12 -				GAS	210941	MG6109	MG6110			516004
						GAS	211220	SG6111	SG6112			

MITSUBISHI (J)

ASX

	(GA_W_) 02.10-			GAS	210538	MG2691	MG2692			516004
				GAS	211121	SG2693				

CARISMA

1.6, 1.9 TD	(DA)	07.95 - 02.99								
1.8, 1.8 GDI, 1.8 16V	(DA)	07.95 - 02.99			GAS	210788	MG4519	MG4524		516004
1.6, 1.8 GDI, 1.9 D-Di	(DA)	03.99 - 06.06			GAS	210524	MG2639	MG2640		516004
					GAS	211183	SG4523			

COLT II/MIRAGE

1.2, 1.5, 1.6 Turbo	(C1)	02.84 - 05.86			GAS	210518	MG2603			516004
1.8 D		02.84 - 05.86			GAS	211593	TG2604			
1.2, 1.3, 1.5, 1.6 Turbo	(C1)	06.86 - 04.88			GAS	210519	MG2605			516004
1.8 D,		06.86 - 04.88			GAS	211593	TG2604			
1.2, 1.3, 1.5, 1.6 Turbo 4x4	(C1)	06.86 - 04.88			GAS	210519	MG2605			516004
1.8 D 4x4		06.86 - 04.88			GAS	211593	TG2604			

COLT III/MIRAGE

excl. ABS, 4x4	(C5)	04.88 - 05.92			GAS	210393	MG1701			516004
					GAS	211078	SG1702			

COLT IV/MIRAGE

1.3, 1.6, 1.6 4x4	(CA, CC4A)	12.91 - 12.96			GAS	210525	MG2641	MG2642		516004
					GAS	211108	SG2607			
1.8 GTI	(CA5A)	12.91 - 12.96			GAS	210526	MG2643	MG2644		516004
					GAS	211108	SG2607			

COLT V

excl. 4x4	(CJ)	09.95 - 05.97			GAS	210527	MG2645	MG2646		516004
					GAS	211108	SG2607			
excl. 4x4	(CJ)	06.97 - 07.05			GAS	210533	MG2675	MG2676		516004
					GAS	211108	SG2607			

COLT VI

excl. 4x4	(Z)	06.04 - 06.12			GAS	210534	MG2677	MG2678		516004
					GAS	212059	TG6007			

CORDIA

1.4, 1.5, 1.6, 1.8 excl. 4x4	(A21_A)	10.82 - 12.86			GAS	210520	MG2608			516004
					GAS	211469	TG1706			

ECLIPSE

excl. 4x4	(D21A, D22A)	04.91 - 03.94			GAS	210523	MG2626			516004
					GAS	211109	SG2609			
4x4	(D27A)	04.91 - 03.94			GAS	210523	MG2626			516004
					GAS	211114	SG2655			

MITSUBISHI (J)

2.0 excl. 4x4	(D32A)	12.95 - 1999				GAS	211115	SG2656			516010
						GAS	211116	SG2657			

GALANT/SIGMA/SAPPORO/LAMBDA

1.6, 1.8, 1.8 Turbo, 2.0 excl. □, ABS 2.0 Turbo, 1.8 Turbo D excl. □, ABS	(E1)	09.83 - 08.87 09.83 - 08.87				GAS	210520	MG2608			516004
						GAS	211110	SG2611			
1.6, 1.8, 2.0 excl. 4X4, 4WS, □ 1.8 Turbo D excl. 4X4, 4WS, □	(E3)	09.87 - 10.92 09.87 - 10.92				GAS	210521	MG2612			516004
						GAS	211110	SG2611			
2.0, 2.0 GTI 16V 4X4, incl. 4WS	(E38A, E39A)	06.88 - 10.92									
1.8, 2.0, 2.0 D, 2.0T D excl. †, □ 2.0 24V, 2.5 V6 4X4 excl. †, □	(E5, E64) (E75A, E88A)	11.92 - 08.96 11.92 - 08.96				GAS	211112	SG2648			
						GAS	211111	SG2635			
excl. † excl. †	(EA)	10.96 - 2004				GAS	211112	SG2648			
						GAS	211608	TG2649			

GRANDIS

2.4i excl. † 2.0 DiD excl. †	(NA 4W) (NA 8W)	04.04 - 12.11 09.05 - 12.11				GAS	210536	MG2685	MG2686		516004
						GAS	211624	TG2687			

JEEP

52, J3, J3R J54, J56, J58		01.54 - 12.75 01.74 - 04.77				GAS	211367	HG1210			
						GAS	211367	HG1210			
J20, J30, J40 J54, J56, J57, J58, J59		01.61 - 05.77 -				OIL	201377	T 1303			
						OIL	201377	T 1303			

L200

1.6, 2.0, 2.5 D 4X2	(K11T, K12T, K14T)	11.86 - 08.96				GAS	211601	TG2622			
						GAS	211499	HG2106			
2.0, 2.6, 2.5 D 4X4	(K22T, K32T, K33T) (K24 5, K34 T)	11.86 - 08.96				GAS	211602	HG2623			
						GAS	211603	HG2624			
2.0, 2.4, 2.5 D 4X2	(K62T, K65T, K64T)	01.96 - 03.03				GAS	211612	HG2658			
						GAS	211499	HG2106			
2.4, 2.5 D 4X4	(K74T, K75T)	06.96 - 03.03				GAS	211606	HG2637			
						GAS	211603	HG2624			
	(KA T, KB T)	11.05 -				GAS	211117	SG2679			
						GAS	211622	TG2680			

L300

1.6, 2.3 D 4X2	(L032P, L062P) (L038P, L068P)	05.80 - 10.86				OIL	201311	H 0701			
						GAS	211367	HG1210			
1.8, 2.0 4X4	(L035G, L037G)	05.80 - 10.86				OIL	201311	H 0701			
						OIL	201604	H 2625			
1.6, 2.0, 2.5 D 4X2	(P02V, P03V, P05V) (P12V, P13V, P15V)	11.86 - 04.94				OIL	201645	H 2862			
						OIL	201368	H 1211			
2.0 4X4	(P23V, P24V)	11.86 - 04.94									
						OIL	201634	T 2836			
1.6, 2.3 D excl. 4X4	(L032P, L038P)	05.80 - 10.86				OIL	201311	H 0701			
1.6 4X2	(L032P)	11.86 - 04.94				OIL	201311	H 0701			
						OIL	201368	H 1211			

MITSUBISHI (J)

2.5 D 4X2	(L032P, L039P)	11.86 - 04.94			±	OIL	201605	H 2636			
					∞	OIL	201368	H 1211			
1.6 4X2	(L032P)	05.80 - 10.86			±	OIL	201311	H 0701			
					∞	OIL	201368	H 1211			
1.8, 2.0 4X4	(L035G, L037G)	05.80 - 10.86			±	OIL	201311	H 0701			
					∞	OIL	201604	H 2625			
2.3 D 4X2	(L038P)	05.80 - 10.86			±	OIL	201311	H 0701			
					∞	GAS	211367	HG1210			
2.0 2.5 D 4X2	(P03W, P05W)	11.86 - 04.94			±	OIL	201645	H 2862			
					∞	OIL	201368	H 1211			

LANCER II

1.2, 1.4	(A155A, A156A)	09.82 - 01.84			/						
					∞	GAS	211469	TG1706			

LANCER III

1.2, 1.5, 1.8 D	(C12, C14, C15)	01.84 - 05.86			∞	GAS	210518	MG2603			516004
					∞	GAS	211593	TG2604			
1.2, 1.5, 1.8 D	(C12, C14, C15)	06.86 - 04.88			∞	GAS	210519	MG2605			516004
					∞	GAS	211593	TG2604			
1.5, 1.8 D	(C12V, C14V)	01.84 - 05.86			∞	GAS	210518	MG2603			516004
					∞	OIL	201377	T 1303			
1.5, 1.8 D	(C12V, C14V)	06.86 - 06.92			∞	GAS	210519	MG2605			516004
					∞	OIL	201377	T 1303			

LANCER IV

excl. ABS, 4X4	(C6)	04.88 - 04.92			∞	GAS	210393	MG1701			516004
					∞	GAS	211107	SG2606			

LANCER V

1.3, 1.6 incl. 4X4, 2.0 D excl. ABS, 1.8 GTi (CB5A)	(CB1A, CB4A) (CB8A, CD4A)	05.92 - 11.95			∞	GAS	210525	MG2641	MG2642		516004
					∞	GAS	211108	SG2607			
1.8 GTi 16V	(CB5A)	05.92 - 12.96			∞	GAS	210526	MG2643	MG2644		516004
					∞	GAS	211108	SG2607			
1.6, 2.0 D excl. ABS, 4X4	(CB4W, CB8W)	06.92 - 06.03			∞	GAS	210525	MG2641	MG2642		516004
					∞	GAS	211594	TG2614			
1.6 4X4 excl. ABS	(CB4W)	06.92 - 06.03			∞						
					∞	GAS	211594	TG2614			

LANCER VI

1.3, 1.5, 1.6, 2.0	(CK1, CK2, CK4, CP9)	12.95 - 05.97			∞	GAS	210527	MG2645	MG2646		516004
					∞	GAS	211108	SG2607			
1.3, 1.5, 1.6	(CK1, CK2, CK4)	06.97 - 08.03			∞	GAS	210533	MG2675	MG2676		516004
					∞	GAS	211108	SG2607			

LANCER VII

1.3, 1.6 excl. ❸	(CS1A, CS3A)	06.03 - 12.08			∞	GAS	210535	MG2681			516004
					±	GAS	211118	SG2682			
2.0 ❸	(CS9A)	01.04 - 12.08			∞						
					±	GAS	211118	SG2682			

MITSUBISHI (J)

1.6, 2.0 excl. 4x4	(CS3W, CS9W)	06.03 - 12.08				GAS	210535	MG2681			516004
1.6, 2.0 4x4	(CS3W, CS9W)	06.03 - 12.08									

LANCER VIII

1.5, 1.8, 2.0 Di-D excl. 4x4	(CY)	01.08 -				GAS	210537	MG2689	MG2688		516004
						GAS	211120	SG2690			

OUTLANDER II

2.0, 2.2 HDi, 2.4	(CW)	11.06 - 11.12				GAS	210225	MG0987	MG0988		516004
						GAS	211358	TG0989			

PAJERO/SHOGUN/MONTERO

L042G, L043G, L044G L047G, L048G, L049G, P25L	(L04_G)	12.82 - 12.91 01.85 - 12.91				GAS	211595	HG2615			
L141G, L144G, L146G, L149G	(L14_G)	01.88 - 12.91				GAS	211595	HG2615			
V21, V23, V24, V25, V26 excl. 4x4 V41, V43, V44, V45, V46 excl. 4x4	(V2_C/W) (V4_C/W)	12.90 - 04.00 12.90 - 04.00				GAS	211598	HG2618			
V64W, V65W, V68W V74W, V75W, V78W	(V6_W) (V7_W)	04.00 - 12.06				GAS	211113	SG2650			
Pinin, Montero	(H66W, H67W, H77W)	10.99 - 06.07				GAS	210528	MG2652			
Sport	(K94W, K96W)	11.98 -				GAS	211598	HG2618			
3.2 D, 3.8 V6	(V80, V90)	02.07 -				GAS	211119	SG2683			

SANTAMO

incl. 4x4		03.99 - 12.04				GAS	210522	MG2620			516004
						GAS	211600	TG2621			

SIGMA

3.0 V6 excl. ECS 4x4	(F16A)	12.90 - 07.96				GAS	210529	MG2659			516004
3.0 V6 excl. ECS	(F07W)	01.93 - 07.96				GAS	210529	MG2659			516004
						GAS	211614	TG2661			

SPACE GEAR, L400

2.0, 2.4, 2.5 TD 4x2 4x4	(PA3W, PA4W, PA5W)	05.95 - 05.00									
2.0, 2.5 TD 4x2 4x4	(PA3V/5V, PB3V/5V)	05.95 - 05.00									
2.4, 2.5 TD 4x4 4x4	(PD4W, PD5W)	05.95 - 05.00									
2.4, 2.5 TD 4x4 4x4	(PD4V, PD5V)	05.95 - 05.00									

MITSUBISHI (J)

SPACE RUNNER

incl. 4X4	(N11W, N18W, N21W)	10.91 - 08.99				GAS	210522	MG2620			516004
						GAS	211600	TG2621			
excl. 4x4	(N63, N64)	08.99 - 01.03				GAS	210530	MG2667	MG2668		516004
						GAS	211620	TG2669			

SPACE WAGON

1.6, 1.8, 2.0, 1.8 TD excl. 4X4	(D04W, D05V/W) (D09V, D09W)	02.83 - 10.91				GAS	210520	MG2608			516004
						GAS	211469	TG1706			
2.0 4X4	(D08W)	02.85 - 10.91									
						GAS	211469	TG1706			
incl. 4X4	(N3_W, N4_W)	11.91 - 10.98				GAS	210522	MG2620			516004
						GAS	211600	TG2621			
incl. 4X4	(N84W, N94W)	06.98 - 05.00				GAS	210531	MG2671	MG2670		516004
						GAS	211621	TG2672			
incl. 4X4 excl. High ground clearance sus.	(N83W, N84W, N94W)	06.00 - 12.04				GAS	210531	MG2671	MG2670		516004
						GAS	211621	TG2672			

TREDIA

1.4, 1.5, 1.6, 1.8 excl. 4X4	(A21_)	09.82 - 07.86				GAS	210520	MG2608			516004
						GAS	211469	TG1706			
1.8, 2.0 4x4	(A215G, A217G)	03.85 - 07.86									
						GAS	211469	TG1706			

NISSAN (J)

100 NX

1.6, 2.0 excl. ₪	(B13)	03.90 - 10.94				GAS	210546	MG2857	MG2858			516004
						GAS	210551	MG2887	MG2886			516004

240 MICROBUS

	(KC, C, HC, DC, QC) (DQC, GHC, GHQ)	01.66 - 09.67				GAS	211367	HG1210				
						GAS	211367	HG1210				
	(GQC, GC, VC)	01.66 - 09.67				GAS	211367	HG1210				
						GAS	211367	HG1210				
	(KC, C, HC, DC, QC) (DQC, GHC, GHQ)	10.67 - 09.71										
						GAS	211367	HG1210				
H		10.71 - 12.75										
						GAS	211367	HG1210				

ALMERA

incl. 2.0 GTi	(N15)	07.95 - 07.97		31A		GAS	210552	MG2889	MG2888			516004
				31B		GAS	211126	SG2890				
	(N15)	08.97 - 03.00		31A		GAS	210806	MG4815	MG4816			516004
				31B		GAS	211190	SG4821				
	(N16)	04.00 - 07.00				GAS	210807	MG4817	MG4818			516004
						GAS	211194	SG4834				
	(N16E)	01.00 - 07.00				GAS	210807	MG4817	MG4818			516004
						GAS	211191	SG4822				
	(N16)	08.00 - 02.01				GAS	210807	MG4817	MG4818			516004
						GAS	211194	SG4834				
	(N16E)	08.00 - 08.03				GAS	210807	MG4817	MG4818			516004
						GAS	211191	SG4822				
	(N16)	03.01 -				GAS	210807	MG4817	MG4818			516004
						GAS	211191	SG4822				
	(N16E)	09.03 -				GAS	210814	MG4841	MG4840			516004
						GAS	211191	SG4822				

ALMERA TINO

1.8, 2.2 D	(V10)	08.00 - 10.00				GAS	210809	MG4825	MG4826			516004
						GAS	211192	SG4824				
2.0 16V	(V10)	08.00 - 10.00				GAS	210815	MG4843	MG4842			516004
						GAS	211192	SG4824				
1.8, 2.2 D	(V10)	11.00 - 02.06				GAS	210810	MG4827	MG4828			516004
						GAS	211192	SG4824				
2.0 16V	(V10)	11.00 - 02.06				GAS	210815	MG4843	MG4842			516004
						GAS	211192	SG4824				

BLUEBIRD

1.6, 1.8, 1.8 Turbo	(U11)	11.83 - 05.90				GAS	210816	MG4845	MG4844			516004
						GAS	210031	CG2809				516004
2.0, 2.0 V6 Turbo, 2.0 D	(U11)	11.83 - 05.90		T-4		GAS	210031	CG2809				516004
						GAS	210539	MG2808				516004
excl. ₪	(U11)	01.86 - 09.90				GAS	210031	CG2809				516004
						GAS	210539	MG2808				516004
excl. Turbo, ₪	(T12)	12.85 - 12.90				GAS	210539	MG2808				516004
						GAS	210031	CG2809				516004

NISSAN (J)

CABSTAR

	(A320, A321)	1969 - 1975										
					♀	OIL	201634	T 2836				
	(F20)	01.76 - 12.82										
					♀	OIL	201377	T 1303				
	(F22)	01.82 - 06.92			♂	GAS	211489	HG1901				
					♀							
	(F23)	07.92 - 06.10			♂	GAS	211489	HG1901				
					♀	GAS	211606	HG2637				
	75.28, 90.32	06.98 -			♂	GAS	211959	TG4885				
					♀	GAS	211960	TG4886				

CARAVAN-HOMY/E SERIES

E 20, 21, 22		04.78 - 09.80			♂	GAS	211633	HG2835				
E 23		09.80 - 08.86			♂	GAS	211633	HG2835				
						OIL	201634	T 2836				

CEDRIC/GLORIA

2.0, 2.4	(130)	1967 - 1971			±							
					♂	GAS	211626	TG2801				
, 220C, 240C, 260C, 280C	(230)	01.72 - 06.75			±							
					♀	OIL	201377	T 1303				
220 C Diesel	(L230)	01.72 - 06.75			±							
					♀	OIL	201377	T 1303				
, 200 C, 220 C, 260 C, 280 C	(L230)	06.75 - 06.79			±							
					♀	OIL	201377	T 1303				

CHERRY/PULSAR/LANGLEY

100 A, 120 A	(E10)	09.70 - 09.74			/							
					±	OIL	201627	T 2812				
100 A	(E10)	01.71 - 09.74			/							
					+	OIL	201524	T 2418				
, 100, 120, 140 A FI	(F10)	09.74 - 07.78			/	OIL	200032	C 2813				
					±	OIL	201627	T 2812				
100, 120 A FI	(F10)	09.74 - 07.78			/	OIL	200032	C 2813				
					+	OIL	201524	T 2418				
, 100 A, 120 A	(N10)	08.78 - 04.82			/	OIL	200032	C 2813				
					±	OIL	201627	T 2812				
100 A, 120 A	(N10)	08.78 - 04.82			/	OIL	200032	C 2813				
					♀	OIL	201638	T 2840				
1.3, 1.5, 1.7D excl. 1.5 Turbo	(N12)	04.82 - 10.86			⚡	GAS	210540	MG2815				516004
					♂	OIL	201238	T 0118				516010
1.5 Turbo	(N12)	04.82 - 10.86										
					♂	OIL	201238	T 0118				516010

CHERRY/ARNA (EUROPE)

1.2, 1.5 GTI		08.83 - 12.85		1A, 2	⚡	GAS	210101	MG0103	MG0104				516004
Alfa 33 susp.					♂	OIL	201238	T 0118					516010

NISSAN (J)

excl. 4X4, 4 ⁺	(N13)	06.86 - 09.90				GAS	210541	MG2816			516004
						GAS	210542	MG2817			516004
1.6 4X4	(NN13)	06.86 - 09.90				GAS	210817	MG4847	MG4846		516004
						GAS	210818	MG4849	MG4848		516004

CLIPPER

662H, 663H		01.69 - 05.76				GAS	211626	TG2801			516004
						OIL	201377	T 1303			
YT, TWT, YHWT40		01.74 - 12.82									
						OIL	201377	T 1303			

FAIRLADY Z

240 Z, 260 Z	(S30)	01.70 - 06.78				GAS	210030	CG2804			516004

HOMER

Homer 1.5 T Homer 1.25 T	(T641, 642, 20) (T641, T20, F20)	01.68 - 12.76 01.68 - 12.81									516004
						OIL	201377	T 1303			

INTERSTAR

	(X70)	07.02 -				GAS	211789	HG3411			
						GAS	211790	HG3412			
	(X70)	08.03 -				GAS	211789	HG3411			
						GAS	211790	HG3412			
	(X70)	07.02 -				GAS	211789	HG3411			
						OIL	201791	H 3413			
	(X70)	08.03 -				GAS	211789	HG3411			
						OIL	201791	H 3413			

JUKE

	(F15)	06.10 -				GAS	210834	MG4903	MG4902		516004
						GAS	211967	TG4904			

KUBISTAR

excl. Pampa, CU+ (800 Kg)	(X76)	08.03 -				OIL	200631	M 3402		600390	516004
						GAS	210631	MG3402			
						GAS	211786	TG3403			
Pampa	(X76)	08.03 -				OIL	200654	M 3465		600390	516004
						GAS	210654	MG3465			
						GAS	211816	TG3464			
CU+ (800 Kg)	(X76)	08.03 -				OIL	200631	M 3402		600390	516004
						GAS	210631	MG3402			
						GAS	211815	TG3463			

LAUREL

1.8	(C30)	01.68 - 02.70				OIL	200029	C 2802			516004
						GAS	211626	TG2801			516010
180 L, 200 L, 260 L, 280 L	(C130, C131)	01.72 - 01.77				OIL	200029	C 2802			516004

NISSAN (J)

180 L, 200 L, 260 L, 280 L	(KC130, KC131)	01.72 - 01.77			/	OIL	200029	C 2802			516004
					♀						
180 L, 200 L, 240 L, 260 L, 280 L	(C230, C231)	02.77 - 1980			/	OIL	200029	C 2802			516004
					♂						
180 L, 200 L, 240 L, 280 L	(C31)	1981 - 1985			/	OIL	200029	C 2802			516004
					♀						
180 L, 200 L, 240 L, 280 L	(C32)	11.84 - 06.90			/						516004
					♀	GAS	211122	SG2803			

LEOPARD

1,8	(JF30)	01.80 - 12.82			/	GAS	210030	CG2804			516004
					♀	GAS	211122	SG2803			
2.0, 2.8 SFL, 3.0 Turbo	(PF30, HF30)	01.80 - 12.82			/	GAS	210030	CG2804			516004

MAXIMA

excl. ☼	(J30)	10.88 - 10.94			♀	GAS	210543	MG2823	MG2822			516004
				excl. ☼	/	GAS	210034	CG2824				
excl. ☼	(A32)	10.94 - 08.00			♀	GAS	210553	MG2891	MG2892			516004
					♀	GAS	211127	SG2893				
excl. ☼	(CA33)	01.00 - 07.00			♀	GAS	210820	MG4857	MG4856			516004
					♂	GAS	211953	TG4858				
excl. ☼	(CA33)	08.00 - 11.03			♀	GAS	210821	MG4859	MG4860			516004
					♂	GAS	211954	TG4861				

MICRA/MARCH

	(K10)	12.82 - 11.92			♀	OIL	200550	M 2881			516004
					♀	OIL	201124	S 2827			

MICRA/MARCH II

	(K11)	08.92 - 02.03			♀	GAS	210547	MG2869	MG2870			516004
		08.92 - 02.03			♂	GAS	211628	TG2828				516010

MICRA/MARCH III

	(K12)	01.03 - 05.10			♀	GAS	210812	MG4835	MG4836	600731	600732	516004
					♂	GAS	211951	TG4837				
C+C	(K12)	08.05 - 06.10			♀	GAS	210812	MG4835	MG4836	600731	600732	516004
					♂	GAS	211951	TG4837				

MICRA IV

	(K13)	05.10 -			♀	GAS	210832	MG4893	MG4894			516004
					♂	GAS	211964	TG4895				

MICRA V

	(K14)	12.16 -			♀	GAS	212134	MG4915	MG4914			516004
					♂	GAS	212135	TG4916				

MURANO

	(Z50)	03.05 - 09.08			♀	GAS	210819	MG4853	MG4854			516004
					♂	GAS	211952	TG4855				

NISSAN (J)

NOTE

	(E11)	03.06 - 06.12			GAS	210830	MG4883	MG4882	600731	600732	516004
					GAS	211958	TG4884				516010
	(E12)	06.13 -			GAS	210832	MG4893	MG4894			516004
					GAS	211964	TG4895				516010

NV200

		07.10 -			GAS	212143	MG4917	MG4918			516004
					GAS	212144	TG4919				

NV400

	excl. ruote gemelle	11.11 -			GAS	210875	MG5221				
					GAS	212006	HG5222				
	excl. ruote gemelle	11.11 -			GAS	210875	MG5221				
					GAS	212007	HG5223				
	incl. ruote gemelle	11.11 -			GAS	212118	MG5231				
					GAS	212008	HG5224				

PATHFINDER

	(R50)	09.97 - 01.99			GAS	210808	MG4819	MG4820			516004
					GAS	211950	TG4823				
	(R50)	02.99 - 12.04			GAS	210822	MG4863	MG4862			516004
					GAS	211955	TG4864				
	(R51)	01.05 -			GAS	211196	SG4891				
					GAS	211963	TG4892				

PATROL/SAFARI

	(160, 260)	06.80 - 03.89			+	GAS	211629	HG2829			
					♀	GAS	211630	HG2830			
160-743, 260-743		04.89 - 02.98			+	GAS	211631	HG2831			
					♀	GAS	211490	HG1902			
	GR I	(Y60)			+	GAS	211631	HG2831			
					♀	GAS	211632	HG2832			
	GR II	(Y61)			+	GAS	211942	HG4801			
					♀	GAS	211943	HG4802			

PICK-UP/CAB/KING CAB/NAVARA

	(520, 521, 620)	01.65 - 12.78			♂	GAS	211633	HG2835			
					♀	OIL	201634	T 2836			
	4X2 incl. King Cab 4X4 incl. King Cab	(720)			♂	GAS	211635	HG2837			
					♀	OIL	201634	T 2836			
	4X4 incl. King Cab	(720)			♂	GAS	211635	HG2837			
					♀	GAS	211596	HG2616			
	4X2	(GD21)			♂	GAS	211489	HG1901			
					♀	GAS	211636	HG2838			
	4X4	(MD21)			♂	GAS	211637	HG2839			
					♀	GAS	211636	HG2838			
	4X2	(D22)			♂	GAS	211944	TG4809			
					♀	GAS	211636	HG2838			

NISSAN (J)

4X4	(D22)	02.98 - 04.05			♂	GAS	211945	TG4810			
					♀	GAS	211947	TG4812			
4X4	(D40)	10.04 -			♂	GAS	212123	SG4910			
					♀	GAS	212124	TG4911			

PIXO

	(UA0)	06.09 -			♂	GAS	212120	MG4913	MG4912			516004
					♀	GAS	211966	TG4899				

PRAIRIE

excl. 4X4	(M10)	08.82 - 10.88			♂	GAS	210540	MG2815			516004
					♀	GAS	211638	TG2840			
excl. 4X4	(M11)	10.88 - 07.94			♂	GAS	210543	MG2823	MG2822		516004
					♀	GAS	210035	CG2841			
4X4	(NM11)	10.88 - 07.94			♂	GAS	210543	MG2823	MG2822		516004
					♀						516004

PRIMASTAR

		09.02 -			♂	GAS	210648	MG3442	600150	516004
					♀	GAS	211804	TG3443		

PRIMERA

1.6, 2.0 D excl. ABS	(P10)	06.90 - 06.96			♂	GAS	211125	SG2842			
				32A	♀	GAS	210544	MG2843	MG2844		516004
1.6, 2.0 D ABS	(P10)	06.90 - 06.96			♂	GAS	211125	SG2842			
					♀	GAS	210823	MG4865	MG4866		516004
2.0, 2.0 e GT, 2.0 GTi	(P10)	06.90 - 06.96			♂	GAS	211125	SG2842			
				32B	♀	GAS	210548	MG2871	MG2872		
1.6, 2.0 2.0 D	(W10)	07.90 - 03.98 07.90 - 02.95			♂	GAS	210545	MG2845	MG2846		516004
					♀	GAS	211639	TG2847			
excl. GT, SRi	(P11, WP11)	06.96 - 07.02			♂	GAS	211125	SG2842			
					♀	GAS	211129	SG2898			
GT, SRi	(P11, WP11)	06.96 - 07.02			♂	GAS	211125	SG2842			
					♀	GAS	211129	SG2898			
	(P12, WP12)	01.02 -			♂	GAS	210824	MG4867	MG4868		
					♀	GAS	211193	SG4833			

PULSAR

	(C13)	10.14 -			♂						516004
					♀	GAS	211970	TG4909			516010

QASHQAI/QASHQAI + 2

excl 4x4	(J10)	02.07 - 12.13			♂	GAS	210831	MG4887	MG4888		516004
					♀	GAS	211961	TG4889			
4x4	(J10)	02.07 - 12.13			♂	GAS	210831	MG4887	MG4888		516004
					♀	GAS	211962	TG4890			

QASHQAI II

excl. 4WD	(J11, J11_)	11.13 -			♂	GAS	210835	MG4905	MG4906		516004
					♀	GAS	211968	TG4907			

NISSAN (J)

4WD	(J11, J11_)	11.13-				GAS	210835	MG4905	MG4906			516004
						GAS	211969	TG4908				

SERENA

1.6, 2.0 D, 2.3 D (L, LX, SLX) excl. SGX	(C23M)	07.92 - 09.01				GAS	210549	MG2875	MG2876			516004
				T		GAS	211367	HG1210				
2.0 SLX, SGX 2.0 D SGX, 2.3 D SGX	(C23M)	07.92 - 09.01				GAS	210549	MG2875	MG2876			516004
		11.95 - 09.01		T		GAS	211652	HG2879				
2.0 SE	(C23M)	06.96 - 09.01				GAS	210549	MG2875	MG2876			516004
				T		GAS	211956	HG4869				

SILVIA/GAZELLE/200 SX

200 SX		01.75 - 07.79				OIL	200029	C 2802				516004
	(S110)	08.79 - 07.83										516004
	(S12)	08.83 - 04.88				GAS	210030	CG2804				
1.8 16V Turbo	(S13)	07.88 - 11.94				GAS	210805	MG4807	MG4806			516004
						GAS	211189	SG4808				
2.0 16V Turbo	(S14)	10.93 - 2000				GAS	210825	MG4871	MG4870			516004
						GAS	211195	SG4872				

SKYLINE

160 K, 180 K 200 K, 240 K, 280 D	(C211)	08.77 - 07.81				OIL	200029	C 2802				
1.8, 2.0, 2.8 D excl. 2.0 Turbo	(R30)	08.81 - 07.85				OIL	200029	C 2802				
2.0 Turbo	(R30)	08.81 - 07.85										
1.8, 2.0	(VR30)	08.81 - 07.85				OIL	200029	C 2802				

STANZA

1.6, 1.8, 1.7 D	(T11)	06.81 - 12.85										
1.6, 1.8, 2.0, 2.0 D excl. Turbo	(T12)	01.86 - 12.90				GAS	210539	MG2808				516004

SUNNY/SENTRA

1.2	(B110)	01.70 - 12.74										
1.4 Excellent	(B110)	01.71 - 02.73				OIL	200029	C 2802				
1.2	(B110, B120)	01.70 - 12.74										
120 Y	(B210)	01.73 - 12.75										
120 Y	(B210)	01.73 - 12.75										

NISSAN (J)

120 Y, 140 Y	(B310)	01.78 - 12.81		/																
																				o
140 Y	(B310)	01.78 - 12.81		/																
120 Y, 140 Y	(B310)	01.78 - 12.81		/																
1.3, 1.5, 1.7 D	(B11)	03.82 - 09.85		/		GAS	210540	MG2815												
	(B11)	03.82 - 09.85		/		GAS	210540	MG2815												
		01.83 - 12.91																		
	(B11)	03.82 - 09.85 01.83 - 12.91		/		GAS	210540	MG2815												
excl. 4x4,	(B12, N13)	09.85 - 10.90		/		GAS	210541	MG2816												
4x4	(B12)	06.86 - 09.90		/		GAS	210817	MG4847	MG4846											
1.4, 2.0 D excl.	(N14)	10.90 - 10.95		/		GAS	210546	MG2857	MG2858											
1.6, 2.0 excl. 4x4,	(N14)	10.90 - 10.95		/		GAS	210546	MG2857	MG2858											
4x4	(N14)	10.90 - 10.95		/		GAS	210826	MG4873	MG4874											
excl. 4x4 (Q-BIC) excl. 4x4	(Y10)	11.90 - 12.95 12.91 - 12.95		/		GAS	210546	MG2857	MG2858											
4x4	(Y10)	11.90 - 12.95		/		GAS	210826	MG4873	MG4874											

TERRANO I/PATHFINDER

excl.	(WD21)	07.86 - 02.96				GAS	211644	HG2861												

TERRANO II

excl.	(R20)	10.92 - 09.07				GAS	211644	HG2861													516004

TIIDA

excl 4x4	(SC11X)	05.06 - 06.13		/		GAS	210833	MG4897	MG4896												516004

TRADE

2.0 (made in Spain)		03.87 - 12.00				OIL	201654	H 2882													
2.8 (made in Spain)		03.87 - 03.93				OIL	201655	H 2884													
2.8 (made in Spain)		03.87 - 03.93				OIL	201655	H 2884													
ECO 100		03.87 - 12.00				OIL	201948	T 4813													

NISSAN (J)

URVAN

	(E20)	04.78 - 06.80			♂							
					♀	OIL	201634	T 2836				
	(E23)	07.80 - 10.86			♂							
					♀	OIL	201645	H 2862				
	(E24)	11.86 - 05.97			♂							
					♀	OIL	201646	H 2863				
					♂							
					♀	OIL	201604	H 2625				

VANETTE

	(C120, C220)	01.78 - 06.87			♀							
					♀	OIL	201647	T 2864				
	(C220)	04.87 -			♀							
					♀	OIL	201648	T 2865				
	(GC22)	10.86 - 12.95			♀							
					♀	GAS	211367	HG1210				
	(GC22) (GC32M)	10.86 - 12.95			♀							
					♂	OIL	201649	H 2866				
					♂	OIL	201650	H 2867				

VANETTE CARGO

	(C23M)	09.94 - 05.01			♀							
					♀	GAS	210549	MG2875	MG2876			
				T	♀							
					♀	GAS	211367	HG1210				
	(C23M)	09.94 - 05.01			♀							
					♀	GAS	210549	MG2875	MG2876			
				T +	♀							
					♀	GAS	211652	HG2879				

VIOLET

	(L710)	01.73 - 04.77			/							
					♂							
	(L710)	01.73 - 04.77			/							
					♂	GAS	211626	TG2801				
	(A10)	05.77 - 12.81			/							
					♂							
	(A10)	05.77 - 12.81			/							
					♀	OIL	201377	T 1303				

X-TRAIL

	(T30)	07.01 - 05.07			♀							
					♀	GAS	210828	MG4879	MG4878			
					♀							
					♀	GAS	210829	MG4881	MG4880			
	(T31)	06.07 - 07.14			♀							
					♀	GAS	210665	MG3491	MG3490			
					♀							
					♀	GAS	211826	TG3488				
	(T32)	12.13 -			♀							
					♀	GAS	211969	TG4908				

OPEL (D)

ADAM

		10.12.-				GAS	210873	MG5217	MG5216	600500	516004
						GAS	212005	TG5218			516010

AGILA

	(H00)	09.00 - 12.07				GAS	210574	MG2995	MG2996	600620	516004
						GAS	211696	TG2969			
	1.3 CDTi	(H00)	08.03 - 12.07				210874	MG5219	MG5220		516004
							211696	TG2969			
	(H08)	04.08.-				GAS	210748	MG4049	MG4050		516004
						GAS	211867	TG4051			516010

AMPERA

		11.11.-									516004

ANTARA

	(L07)	05.06.-				GAS	210869	MG5205	MG5206	600170	516004
						GAS	211706	TG2998			

ASCONA A/B

	(81, 84, 86, 87, 88, 89)	1970 - 08.75									
						OIL	201660	T 2902			
	(81, 86, 87, 88)	09.75 - 08.81				OIL	201661	T 2903			
						OIL	201660	T 2902			

ASCONA C

	> Ch. F1003026, > Ch. F5000000, > Ch. F6000000	(81, 84, 86, 87, 88, 89)	08.81 - 08.84				GAS	210041	CG2904		516004
							GAS	211662	TG2905		
	(Ch. F1003027>, Ch. F5000001>, Ch. F6000001>)		09.84 - 10.88				GAS	210042	CG2906		516004
							GAS	211662	TG2905		

ASTRA F

	excl. GT, GSi	(53, 54, 56, 57, 58, 59)	09.91 - 03.98				OIL	200043	C 2907	600020	516004	
							GAS	210043	CG2907			
							OIL	201663	T 2908			
							GAS	211663	TG2908			
	GT	(53, 54, 56, 57, 58, 59)	09.91 - 03.98				GAS	210043	CG2907	600020	516004	
							GAS	211663	TG2908			
	GSi	(53, 54, 56, 57, 58, 59)	09.91 - 03.98				GAS	210043	CG2907	600020	516004	
							GAS	211685	TG2939			
	Caravan	(51, 52)	09.91 - 03.98				OIL	200043	C 2907	600020	516004	
							GAS	210043	CG2907			
							OIL	201664	T 2909			
					excl. ♡		GAS	211664	TG2909			
	(53_B)		09.91 - 03.98				GAS	210043	CG2907	600020	516004	
							GAS	211663	TG2908			

OPEL (D)

ASTRA G

excl. 2.0 OPC	(F48, F08, F69)	04.98 - 03.04				GAS	210562	MG2953	MG2954	600380	516004
						GAS	211689	TG2955			
excl. 2.0 OPC, ?, ♀	(F35)	04.98 - 08.04				GAS	210562	MG2953	MG2954	600380	516004
				excl. Ⓜ		GAS	211690	TG2956			
				excl. ♀		GAS	211690	TG2956			

ASTRA H

1.4, 1.6 incl. GTC, Ⓜ, excl. IDS, ♀	(A04)	03.04 - 05.14				GAS	210569	MG2983	MG2982	600160	516004
						GAS	211703	TG2986			
1.8, 1.3 CDTi, 1.7 CDTi, 1.9 CDTi incl. GTC, Ⓜ, excl. IDS, ♀	(A04)	03.04 - 05.14				GAS	210569	MG2983	MG2982	600160	516004
						GAS	211703	TG2986			
1.4, 1.6 incl. Ⓜ, excl. IDS, ♀	(A04)	08.04 - 05.14				GAS	210569	MG2983	MG2982	600160	516004
						GAS	211702	TG2981			
1.8, 1.3 CDTi, 1.7 CDTi, 1.9 CDTi incl. Ⓜ, excl. IDS, ♀	(A04)	08.04 - 05.14				GAS	210569	MG2983	MG2982	600160	516004
						GAS	211702	TG2981			

ASTRA J

	(P10)	12.09 -				GAS	210871	MG5211	MG5210		516004
						GAS	212003	TG5212			516010

CALIBRA

2.0, 2.0 16V, 2.5 V6 excl. 2.0 Turbo, ♀	(85)	06.90 - 07.97				GAS	210044	CG2912	600030		
				excl. ♀		GAS	211667	TG2913			

CAMPO/BRAVA

TFR Series 4X2	(TF)	08.91 -									
TFS Series 4X4	(TF)	08.91 -				GAS	211670	HG2916			
						GAS	211490	HG1902			

COMBO

Kadett E Combo		01.86 - 07.94				OIL	200046	C 2927			516004
						GAS	210046	CG2927			516004
						OIL	201679	T 2929			
Corsa B Combo	(71)	07.94 - 10.01				OIL	200554	M 2917		600370	516004
						GAS	210554	MG2917			
						OIL	201679	T 2929			
Corsa C Combo Van, Tour		10.01 -				GAS	210566	MG2971	MG2972	600380	516004
						GAS	211699	TG2974			
Furgonato, Tour excl. trasporto persone	(X12)	02.12 -				GAS	210176	MG0691	MG0692	600541	600542
						GAS	211307	TGO693			
Promiscuo (trasporto persone)	(X12)	02.12 -				GAS	210176	MG0691	MG0692	600541	600542
						GAS	212016	TG5325			

COMMODORE A/B/C

2.2, 2.5		01.67 - 01.72				OIL	201673	T 2920			
						GAS	211674	TG2921			

OPEL (D)

2.5, 2.5 GS, 2.8 GS, 2.8 GS/E		01.72 - 07.78			±	OIL	201673	T 2920			
					±	OIL	201675	T 2922			
2.5 S		08.78 - 12.82			/	OIL	200045	C 2923			
					±	OIL	201675	T 2922			

CORSA A

excl. 1.6 GSI		09.82 - 03.93			↗	OIL	200554	M 2917	600370	516004
					↗	GAS	210554	MG2917		516004
					±	OIL	201671	T 2918		516010
					±	GAS	211671	TG2918		516010
1.6 GSI		05.88 - 03.93			↗	GAS	210554	MG2917	600370	516004
					±	GAS	211671	TG2918		516010

CORSA B

excl. GSI 1.6 16V		02.93 - 11.00			↗	OIL	200554	M 2917	600370	516004
					↗	GAS	210554	MG2917		516004
					±	OIL	201671	T 2918		516010
					±	GAS	211671	TG2918		516010
GSI 1.6 16V		02.93 - 11.00			↗	GAS	210554	MG2917	600370	516004
					±	GAS	211671	TG2918		516010
Combo		07.94 - 10.01			↗	OIL	200554	M 2917	600370	516004
					↗	GAS	210554	MG2917		516004
					∞	OIL	201679	T 2929		

CORSA C

1.0i, 1.2i excl.	(F08, F68)	09.00 - 12.09		33A	↗	GAS	210566	MG2971	MG2972	600380	516004
					±	OIL	201695				
					±	GAS	211695	TG2967			
1.0i, 1.2i	(F08, F68)	09.00 - 12.09			↗	GAS	210566	MG2971	MG2972	600380	516004
					±	GAS	211698	TG2973			
1.4i Excl.	(F08, F68)	09.00 - 12.09			↗	GAS	210566	MG2971	MG2972	600380	516004
					±	GAS	211698	TG2973			
1.4i	(F08, F68)	09.00 - 12.09		33B	↗	GAS	210566	MG2971	MG2972	600380	516004
					±	GAS	211698	TG2973			
1.7 Di excl.	(F08, F68)	09.00 - 12.09		33A	↗	GAS	210566	MG2971	MG2972	600380	516004
					±	OIL	201695				
					±	GAS	211695	TG2967			
1.7 Di	(F08, F68)	09.00 - 12.09			↗	GAS	210566	MG2971	MG2972	600380	516004
					±	GAS	211698	TG2973			
1.8i, 1.7 DTi excl.	(F08, F68)	09.00 - 12.09			↗	GAS	210566	MG2971	MG2972	600380	516004
					±	GAS	211698	TG2973			
1.8i, 1.7 DTi	(F08, F68)	09.00 - 12.09		33B	↗	GAS	210566	MG2971	MG2972	600380	516004
					±	GAS	211698	TG2973			
Combo Van, Tour	(F08, W5L)	09.00 - 12.09			↗	GAS	210566	MG2971	MG2972	600380	516004
					∞	GAS	211699	TG2974			

CORSA D

	(S07)	07.06 -			↗	GAS	210571	MG2987	MG2988	600500	516004
					±	GAS	211704	TG2989	600781	600782	516010

OPEL (D)

CORSA E

excl. 1.6 turbo, ,	(X15)	09.14 -			GAS	210877	MG5229	MG5228	600500	516004
					GAS	212010	TG5230		600781	600782
Van	(X15)	09.14 -			GAS	210877	MG5229	MG5228	600500	516004
					GAS	212010	TG5230		600781	600782

FRONTERA A

incl. sport , > Ch. SV720102		03.92 - 02.95			GAS	211644	HG2861			
					GAS	211676	HG2925			
incl. sport , Ch. SV720103 >		02.95 - 10.98			GAS	211687	HG2947			
					GAS	211676	HG2925			

FRONTERA B

incl. sport		10.98 - 12.05			GAS	211692	HG2960			
					GAS	211693	HG2961			

INSIGNIA A

	(G09)	07.08 - 03.17			GAS	210870	MG5207	MG5208	600440	516004
					GAS	212002	TG5209			516010

KADETT A / B

		03.63 - 08.73			OIL	201677	T 2926			
					GAS	211674	TG2921			

KADETT C

, SR		08.73 - 07.79			OIL	201661	T 2903			
					OIL	201675	T 2922			
GT/E, Rallye		08.73 - 07.79			OIL	201661	T 2903			
Caravan City		08.73 - 07.79 08.73 - 07.79			OIL	201661	T 2903			
					GAS	211674	TG2921			

KADETT D

, excl. GTE	(31, 34, 41, 44)	08.79 - 08.84			OIL	200046	C 2927			516004
					GAS	210046	CG2927			516004
					OIL	201662	T 2905			
					GAS	211662	TG2905			
GTE	(31, 34, 41, 44)	02.83 - 08.84			GAS	210046	CG2927			516004
					GAS	211662	TG2905			
	(35, 36, 45, 46)	08.79 - 08.84			OIL	200046	C 2927			516004
					GAS	210046	CG2927			516004
					OIL	201678	T 2928			

KADETT E

, , excl. GSI > Ch. J 2791967 > Ch. J 5273427	(33, 34, 39, 43, 43B, 44, 49)	08.84 - 07.88			OIL	200046	C 2927			516004
					GAS	210046	CG2927			516004
					OIL	201662	T 2905			
					GAS	211662	TG2905			

OPEL (D)

excl. GSI Ch. J 2791968 > Ch. J 5273428 >	(33, 34, 39, 43, 43B, 44, 49)	08.88 - 07.91		/	OIL	200046	C 2927			516004
				/	GAS	210046	CG2927			516004
				⊖	OIL	201663	T 2908			
				⊖	GAS	211663	TG2908			
GSI > Ch. J 2791967 > Ch. J 5273427	(33, 34, 39, 43, 43B, 44, 49)	08.84 - 07.88		/	GAS	210046	CG2927			516004
				⊖	GAS	211662	TG2905			
GSI Ch. J 2791968 > Ch. J 5273428 >	(33, 34, 39, 43, 43B, 44, 49)	08.88 - 07.91		/	GAS	210046	CG2927			516004
				⊖	GAS	211663	TG2908			
Caravan	(35, 36, 45, 46)	08.84 - 07.91		/	OIL	200046	C 2927			516004
				/	GAS	210046	CG2927			516004
				0	OIL	201664	T 2909			
				♀	GAS	211664	TG2909			
Combo	(38, 48)	01.86 - 07.94		0	OIL	200046	C 2927			
				/	GAS	210046	CG2927			516004
				⊗	OIL	201679	T 2929			

MANTA A

	(58, 59)	09.70 - 08.75			⊖					
					⊖	OIL	201675	T 2922		

MANTA B

excl. GT/E, GSI	(58, 59)	09.75 - 08.88			⊖	OIL	201661	T 2903		
					⊖	OIL	201660	T 2902		
GT/E, GSI	(58, 59)	09.75 - 08.88			⊖					
					⊖	OIL	201660	T 2902		

MERIVA A

	(X03)	05.03 - 05.10			⚡	GAS	210566	MG2971	MG2972	600380	516004
					⊗	GAS	211699	TG2974			

MERIVA B

	(S10)	06.10 -			⚡	GAS	210872	MG5213	MG5214		516004
					⊗	GAS	212004	TG5215			

MOKKA

excl. 4X4, ⚡	(J13)	06.12 -			⚡	GAS	210876	MG5225	MG5226		516004
					⊖	GAS	212009	TG5227			516010

MONTEREY

	(UBS)	06.92 - 03.95			⊖	GAS	211670	HG2916		
					⊗	GAS	211680	HG2930		
	(UBS)	04.95 - 07.98			⊖	GAS	211688	HG2949		
					⊗	GAS	211680	HG2930		
		01.98 -			⊖	GAS	211707	HG2999		
					⊗	GAS	212001	HG5204		

OPEL (D)

MONZA

	(22)	02.78 - 03.83		/	OIL	200045	C 2923			516004
				⊥						
	(22)	04.83 - 08.86		/	OIL	200045	C 2923			516004
				⊥						

MOVANO

2.8T, 3.3T, 3.5T	(E9, F9, J9)	07.98 -		∞	GAS	211789	HG3411			
				∞	GAS	211790	HG3412			
3.5T	(H9, U9)	07.98 -		∞	GAS	211789	HG3411			
				∞	OIL	201791	H 3413			

MOVANO B

excl. ruote gemelle	(X62)	05.10 -		∞	GAS	210875	MG5221			516004
				∞	GAS	212006	HG5222			
excl. ruote gemelle	(X62)	05.10 -		∞	GAS	210875	MG5221			516004
				∞	GAS	212007	HG5223			
incl. ruote gemelle	(X62)	05.10 -		∞	GAS	212118	MG5231			516004
				∞	GAS	212008	HG5224			

OMEGA A

1.8, 2.0, 2.4 excl. ⚡	(16, 17, 19)	09.86 - 05.94		∞	GAS	210555	MG2932			516004
2.3 D, 2.3 TD excl. ⚡		09.86 - 05.94		⊥	GAS	211682	TG2933			516010
2.6, 2.8, 3.0, 3.0 24V excl. Lotus, ⚡	(16, 17, 19)	09.86 - 05.94		∞	GAS	210556	MG2934			516004
				⊥	GAS	211682	TG2933			516010
Caravan excl. ⚡	(66, 67)	09.86 - 05.94		∞	GAS	210555	MG2932			516004
				⊥	GAS	211683	TG2935			516010

OMEGA B

2.0, 2.0 16V, 2.2 16V excl. ⚡	(25, 26, 27)	05.94 - 07.03		∞	GAS	210557	MG2940			516004
				⊥	GAS	211682	TG2933			516010
2.0 DTi, 2.2 DTi, 2.5 TD, 2.5 DTi 2.5 V6, 3.0 V6, 3.2 V6 excl. ⚡	(25, 26, 27)	05.94 - 07.03		∞	GAS	210558	MG2941			516004
		05.94 - 07.03		⊥	GAS	211682	TG2933			516010
2.0, 2.0 16V, 2.2 16V excl. ⚡	(21, 22, 23)	05.94 - 07.03		∞	GAS	210557	MG2940			516004
				⊥	GAS	211683	TG2935			516010
2.0 DTi, 2.2 DTi, 2.5 TD, 2.5 DTi 2.5 V6, 3.0 V6, 3.2 V6 excl. ⚡	(21, 22, 23)	05.94 - 07.03		∞	GAS	210558	MG2941			516004
		05.94 - 07.03		⊥	GAS	211683	TG2935			516010

REKORD A / B / C

excl. 2.2, 2.6		01.63 - 12.71		⊥	OIL	201673	T 2920			
				⊥	GAS	211674	TG2921			

REKORD D

excl. 2.1 D		01.72 - 08.77		⊥	OIL	201673	T 2920			
				⊥	OIL	201675	T 2922			
2.1 D		01.72 - 08.77		⊥	OIL	201673	T 2920			
				⊥	OIL	201660	T 2902			

OPEL (D)

Caravan		01.72 - 08.77			±	OIL	201673	T 2920			
					±	GAS	211684	TG2936			
1.5 Turbo	(N12)	04.82 - 10.86									
					±	OIL	201238	T 0118			

REKORD E

1.7, 1.9, 2.0		08.77 - 08.86			/	OIL	200045	C 2923			
					±	OIL	201675	T 2922			
2.1 D, 2.2 D, 2.2 TD		08.77 - 08.86			/	OIL	200045	C 2923			
					±	OIL	201660	T 2902			
Caravan		08.77 - 08.86			/	OIL	200045	C 2923			
					±	GAS	211684	TG2936			

SENATOR A / B

	(29)	02.78 - 08.87			/	OIL	200045	C 2923			516004
					±						516010
excl. 3.0 24V,		09.87 - 04.94				GAS	210555	MG2932			516004
					±	GAS	211682	TG2933			516010
3.0 24V excl.		09.89 - 04.94				GAS	210556	MG2934			516004
					±	GAS	211682	TG2933			516010

SIGNUM

> Ch. 48999999 excl.		05.03 - 08.04				GAS	210567	MG2975	MG2976	600770	516004
				excl.	±	GAS	211700	TG2979			
> Ch. 48999999 		05.03 - 08.04				GAS	210568	MG2977	MG2978	600770	516004
				excl.	±	GAS	211701	TG2980			
Ch. 51000001 > excl. IDS		09.04 - 12.08				GAS	210573	MG2993	MG2994		516004
					±	GAS	211700	TG2979			

SINTRA

		11.96 - 04.99				GAS	210563	MG2958			516004
				excl.	±	GAS	211691	HG2959			

TIGRA

1.4 16V, 1.6 16V	(95)	07.94 - 12.00				GAS	210554	MG2917		600370	516004
					±	GAS	211671	TG2918			516010

TIGRA TWINTOP

	(X04)	06.04 -				GAS	210566	MG2971	MG2972	600380	516004
					±	GAS	211695	TG2967			516010

VECTRA A

excl. 4X4, 2.0 16V, 2.5 V6	(86_ 87, 88, 89)	09.88 - 11.95			/	GAS	210044	CG2912		600030	516004
				excl.	±	OIL	201663	T 2908			516010
				excl.	±	GAS	211663	TG2908			516010
2.0 16V excl. 4X4 > Ch. NV199999 > Ch. N1999999 > Ch. N5999999	(86_ 87, 88, 89)	09.88 - 11.92			/	GAS	210044	CG2912		600030	516004
				excl.	±	GAS	211682	TG2933			516010
2.0 16V excl. 4X4 Ch. NV199999 > Ch. N1999999 > Ch. N5999999 >	(86_ 87, 88, 89)	01.93 - 11.95			/	GAS	210044	CG2912		600030	516004
				excl.	±	OIL	201663	T 2908			516010
				excl.	±	GAS	211663	TG2908			516010

OPEL (D)

1.8, 2.0, 2.0 16V Turbo 4X4	(86_87, 88, 89)	09.88 - 11.95			/	GAS	210044	CG2912	600030	516004
				excl.	⊖	GAS	211682	TG2933		516010

VECTRA B

1.6, 1.8, 2.0 1.6 16V, 1.8 16V, 2.0 16V	(36, 38)	08.95 - 03.02				GAS	210560	MG2945	MG2948	600380	516004
						GAS	211130	SG2946			
1.7 TD, 2.0 Di/DTi 16V, 2.2 DTi 16V 2.5, 2.6 V6	(36, 38)	08.95 - 03.02 08.95 - 03.02				GAS	210561	MG2951	MG2952	600380	516004
						GAS	211130	SG2946			
1.6, 1.8, 2.0 1.6 16V, 1.8 16V, 2.0 16V	(31)	08.95 - 03.02				GAS	210560	MG2945	MG2948	600380	516004
				excl.		GAS	211130	SG2946			
1.7 TD, 2.0 Di/DTi 16V, 2.2 DTi 16V 2.5 V6, 2.6 V6	(31)	08.95 - 03.02 08.95 - 03.02				GAS	210561	MG2951	MG2952	600380	516004
				excl.		GAS	211131	SG2957			

VECTRA C

excl. 3.0 CDTi excl. , , IDS > Ch. 48999999	(Z02)	04.02 - 08.04				GAS	210567	MG2975	MG2976	600770	516004
				excl.		GAS	211700	TG2979			
excl. 3.0 CDTi , , excl. IDS > Ch. 48999999	(Z02)	04.02 - 08.04				GAS	210568	MG2977	MG2978	600770	516004
				excl.		GAS	211701	TG2980			
Ch. 51000001 > excl. IDS	(Z02)	09.04 -				GAS	210573	MG2993	MG2994		516004
						GAS	211700	TG2979			

VIVARO

	(J7, F7)	08.01 -				GAS	210648	MG3442	600150	516007
						GAS	211804	TG3443		

ZAFIRA A

excl. 2.0 Turbo OPC	(F75)	04.99 - 07.05				GAS	210564	MG2963	MG2962	600380	516004
						GAS	211694	TG2964			

ZAFIRA B

	(A05)	07.05 -				GAS	210569	MG2983	MG2982	600160	516004
						GAS	211703	TG2986			

ZAFIRA C

	(P12)	10.11 -				GAS	210871	MG5211	MG5210		516004
						GAS	212003	TG5212		516010	

PEUGEOT (F)

106

🚗 0.9, 1.0, 1.1, 1.4, 1.4 D, 1.5 D, Entreprise	(1A, 1C)	09.91 - 04.96		/	OIL	200022	C 0907		600120	516004
				/	GAS	210022	CG0907			
				⊗	OIL	201340	T 0908			
				⊗	GAS	211340	TG0908			
🚗 1.3 Rallye, 1.4 Xsi, 1.6, 1.6 Xsi	(1A, 1C)	09.91 - 04.96		/	OIL	200022	C 0907		600120	516004
				/	GAS	210022	CG0907			
				⊗	GAS	211340	TG0908			

107

🚗 1.0i, 1.4D		07.05 -		⚡	GAS	210223	MG0981	MG0982			516004
				⊕	GAS	211356	TG0983				

108

🚗		05.14 -		⚡	GAS	210223	MG0981	MG0982			516004
				⊕	GAS	211356	TG0983				

204

🚗		10.65 - 01.70		/							
				⚡	OIL	201133	S 3004				
🚗		02.70 - 06.72		/	OIL	200048	C 3005				
				⚡	OIL	201133	S 3004				
🚗		07.72 - 07.77		/	OIL	200048	C 3005				
				⚡	OIL	201133	S 3004				

205

🚗 excl. GTi, CTi, Rallye, 1.7 TD, 🚗 F	(741 A/C, 20 A/C)	02.83 - 09.98		⚡	OIL	200575	M 3009				516004
				⚡	GAS	210575	MG3009				
				⊗	OIL	201344	T 0929				
				⊗	GAS	211709	TG3020				
🚗 1.3 Rallye, 1.6 GTi, 1.9 GTi	(741 A/C, 20 A/C)	12.84 - 09.98		⚡	GAS	210576	MG3011	MG3010			516004
				⊗	GAS	211708	TG3008				
🚗 1.9 Gentry, 1.7 TD	(741 A/C, 20 A/C)	01.90 - 09.98		⚡	OIL	200577	M 3013	M 3012			516004
				⚡	GAS	210577	MG3013	MG3012			
				⊗	OIL	201344	T 0929				
				⊗	GAS	211709	TG3020				
🚗 1.6 CTi, 1.9 CTi	(741B, 20D)	04.86 - 12.94		⚡	OIL	200575	M 3009				516004
				⚡	GAS	210575	MG3009				516004
				⊗	OIL	201344	T 0929				
				⊗	GAS	211709	TG3020				
🚗 F		03.94 -		⚡	GAS	210575	MG3009				516004
				⊗							

206

🚗 1.1, 1.4, 1.6, 1.9 D incl. Entreprise	(2A/C)	09.98 -		34B	⚡	OIL	200588	M 3067	M 3066	600101	600102	516004
				34B	⚡	GAS	210588	MG3067	MG3066			
					⊗	OIL	201726	T 3057				
					⊗	GAS	211726	TG3057				

PEUGEOT (F)

1.4 HDi, 2.0 HDi incl. Entreprise	(2A/C)	12.99 -				OIL	200588	M 3067	M 3066	600101	600102	516004
						GAS	210588	MG3067	MG3066			
				N.D.		OIL	201726	T 3057				
				N.D.		GAS	211726	TG3057				
				H.D.		GAS	211727	TG3060				
2.0 16V	(2A/C)	04.99 -				GAS	210586	MG3061	MG3062	600101	600102	516004
						GAS	211727	TG3060				
CC	(2D)	09.00 -				GAS	210586	MG3061	MG3062	600101	600102	516004
						GAS	211727	TG3060				
SW	(2E/K)	07.02 -				OIL	200588	M 3067	M 3066	600101	600102	516004
						GAS	210588	MG3067	MG3066	600101	600102	
				N.D.		OIL	201726	T 3057				
				N.D.		GAS	211726	TG3057				
				H.D.		GAS	211727	TG3060				

206 +

Plus	(T3E)	01.09 -				GAS	210588	MG3067	MG3066	600101	600102	516004
						GAS	211726	TG3057				

207

	(WA, WC, WD, WK)	02.06 -		11B		GAS	210594	MG3087	MG3086			516004
				11A		GAS	210593	MG3079	MG3080			516004
						GAS	211732	TG3081				

208

Excl. GTi		03.12 -		11B		GAS	210598	MG3103	MG3102			516004
				11A		GAS	210599	MG3105	MG3104			516004
						GAS	211737	TG3099				

301

		04.14 -				GAS	210604	MG3117	MG3116			516004
						GAS	211741	TG3118				

304

		10.69 - 02.70										
						OIL	201133	S 3004				
		03.70 - 06.72				OIL	200048	C 3005				
						OIL	201133	S 3004				
		07.72 - 08.77				OIL	200048	C 3005				
						OIL	201134	S 3006				
> Ch. 4031500		08.77 - 10.79				OIL	200049	C 3014				
						OIL	201134	S 3006				
S > Ch. 329800		03.70 - 02.73				OIL	200048	C 3005				
						OIL	201133	S 3004				
S Ch. 329801 >		03.73 - 04.75				OIL	200048	C 3005				
						OIL	201134	S 3006				
		03.70 - 06.72				OIL	200048	C 3005				
S		07.72 - 07.76				OIL	200048	C 3005				
						OIL	201134	S 3006				

PEUGEOT (F)

305

GL, GR, SR, GLS, GLD, GRD, S, SRD > Ch. 8870212	(581A, 581M)	01.77 - 12.82			/	OIL	200049	C 3014			
					/	OIL	201135	S 3015			
GL, GR, SR, GLS, GLD, GRD, SRD Ch. 8870212 > 8987000	(581A, 581M)	01.82 - 06.82			/	OIL	200049	C 3014			
					/	OIL	201136	S 3016			
GR, SR, GL, GLS (1.1, 1.3, 1.5) GLD, GRD, SRD Ch. 8987001 >	(581A, 581M)	07.82 - 12.85			/	OIL	200578	M 3017			
		07.82 - 07.90			/	OIL	201136	S 3016			
GL, GLS (1.6) Ch. 9370001 >	(581A, 581M)	01.85 - 07.90			/	OIL	200578	M 3017			
					/	OIL	201137	S 3018			
> Ch. 8987000	(581D, 581E)	01.78 - 06.82			/	OIL	200049	C 3014			
					/	OIL	201042	S 0919			
Ch. 8987001 >	(581D, 581E)	07.82 - 07.90			/	OIL	200578	M 3017			
					/	OIL	201042	S 0919			

306

1.1	(7A, 7B, 7C, N3, N5)	01.93 - 08.01			/	GAS	212091	MG0953	MG0952	600110	516004
					⊗	OIL	201344	T 0929			
					⊗	GAS	211709	TG3020			
1.4 (4 m)	(7A, 7B, 7C, N3, N5)	06.94 - 05.01			/	GAS	210210	MG0949	MG0948	600110	516004
					⊗	OIL	201344	T 0929			
					⊗	GAS	211709	TG3020			
1.4 (3/5 m) excl. 175/70x13" excl. 175/65x14"	(7A, 7B, 7C, N3, N5)	01.93 - 08.01			/	GAS	212091	MG0953	MG0952	600110	516004
				N.D.	⊗	OIL	201344	T 0929			
				N.D.	⊗	GAS	211709	TG3020			
				H.D.	⊗	GAS	211708	TG3008			
1.4 (3/5 m) 175/70x13" 175/65x14"	(7A, 7B, 7C, N3, N5)	01.93 - 08.01			/	GAS	210210	MG0949	MG0948	600110	516004
				N.D.	⊗	OIL	201344	T 0929			
				N.D.	⊗	GAS	211709	TG3020			
				H.D.	⊗	GAS	211708	TG3008			
1.6, 1.8 1.8 D, 1.9 D, 1.9 TD, 2.0 HDi	(7A, 7B, 7C, N3, N5)	01.93 - 08.01			/	GAS	210210	MG0949	MG0948	600110	516004
		01.93 - 08.01		N.D.	⊗	OIL	201344	T 0929			
				N.D.	⊗	GAS	211709	TG3020			
				H.D.	⊗	GAS	211708	TG3008			
2.0, 2.0 16V	(7A, 7B, 7C, N3, N5)	01.93 - 08.01			/	GAS	210210	MG0949	MG0948	600110	516004
					⊗	GAS	211708	TG3008			
	(7E, N3, N5)	06.94 - 04.02			/	GAS	210210	MG0949	MG0948	600110	516004
					⊗	GAS	211708	TG3008			
	(7D, N3, N5)	03.94 - 04.02			/	GAS	210210	MG0949	MG0948	600110	516004
					⊗	GAS	211709	TG3020			
Entreprise		01.93 - 05.99			/	GAS	210210	MG0949	MG0948	600110	516004
					⊗	OIL	201344	T 0929			
					⊗	GAS	211709	TG3020			

307

1.4, 1.6, 2.0, 2.0 HDi Excl. Commercial,	(3A/C)	08.00 -			/	GAS	210589	MG3069	MG3070	600090	516004
					⊕	GAS	211729	TG3068			
1.4 HDi, 1.6 HDi Excl. Commercial,	(3A/C)	10.01 -			/	GAS	210590	MG3071	MG3072	600090	516004
					⊕	GAS	211729	TG3068			

PEUGEOT (F)

Commercial	(3A/C)	08.00 - 08.00 -				GAS	210590	MG3071	MG3072	600090	516004
						GAS	211729	TG3068			
SW Excl. Commercial,	(3E, 3H)	03.02 -				GAS	210589	MG3069	MG3070	600090	516004
						GAS	211729	TG3068			
SW Commercial SW	(3E, 3H)	03.02 - 03.02 -				GAS	210590	MG3071	MG3072	600090	516004
						GAS	211730	TG3073			
	(3B)	10.03 -				GAS	210589	MG3069	MG3070	600090	516004

308

	(4A, 4C)	09.07 -				GAS	210595	MG3091	MG3090		516004
						GAS	211733	TG3089			
		09.07 -				GAS	210595	MG3091	MG3090		516004
						GAS	211734	TG3092			
		04.09 -				GAS	210595	MG3091	MG3090		516004
						GAS	211734	TG3092			

308 II

excl. 1.6 THP, 1.6 GT 205, 1.6 Gti, 2.0 GT Hdi,		09.13 -				GAS	210603	MG3115			516004
						GAS	211740	TG3114			

309

1.1, 1.3, 1.4, 1.8 D, 1.9 D 1.6 (XU5), 1.9 (XU9) excl. GTI, GTI 16V	(10C, 10A, 3C, 3A)	10.85 - 12.93 10.85 - 10.89				OIL	200575	M 3009			516004
				N.D.		OIL	201344	T 0929			
				N.D.		GAS	211709	TG3020			
				H.D.		GAS	211708	TG3008			
1.6 (XU5) excl. GTI 1.9 (XU9) excl. GTI, GTI 16V 1.8 TD (XUD7T)	(10C, 10A, 3C, 3A)	11.89 - 12.93 08.88 - 12.93 08.89 - 12.93				OIL	200577	M 3013	M 3012		516004
				N.D.		OIL	201344	T 0929			
				N.D.		GAS	211709	TG3020			
				H.D.		GAS	211708	TG3008			
1.6i (XU5JA) 1.9 GTI, GTI 16 (XU9J, XU9J4)	(10C, 10A, 3C, 3A)	08.88 - 12.93 10.86 - 12.93				OIL	200576	M 3011	M 3010		516004
						GAS	211708	TG3008			

405

1.4, 1.6, 1.8, 1.9 D (GL, GR, SR)	(15B, 4B)	01.87 - 10.95				GAS	210579	MG3026			516004
						OIL	201713	T 3027			
						GAS	211713	TG3027			
1.9 GRi, SRi, Sti	(15B, 4B)	01.87 - 10.95				GAS	210580	MG3028			516004
						OIL	201713	T 3027			
						GAS	211713	TG3027			
1.9 MI-16 excl. 4X4	(15B, 4B)	1987 - 10.95				GAS	210580	MG3028			516004
GRX4, SRX4	(15B, 4B)	01.89 - 10.95				GAS	210579	MG3026			516004
2.0 MI-16, 2.0 T16 4X4	(15B, 4B)	01.89 - 10.95				GAS	210580	MG3028			516004
1.8 TD	(15B, 4B)	03.88 - 10.95				GAS	210580	MG3028			516004
						OIL	201713	T 3027			
						GAS	211713	TG3027			

PEUGEOT (F)

1.4, 1.6, 1.8, 1.9 D excl. 4X4	(15E, 4E)	10.88 - 10.96				GAS	210579	MG3026			516004
						OIL	201713	T 3027			
Entreprise excl. 4X4	(15E, 4E)	10.88 - 10.96				GAS	211713	TG3027			
						GAS	210580	MG3028			516004
1.9 GRi, SRi, STi, 1.8 TD excl. 4X4	(15E, 4E)	10.88 - 10.96				GAS	210580	MG3028			516004
						OIL	201713	T 3027			
						GAS	211713	TG3027			
4X4	(15E, 4E)	10.88 - 10.96				GAS	210580	MG3028			516004

406

1.6, 1.8, 2.0 1.9 D, 1.9 TD, 2.0 HDi	(8B)	10.95 - 05.04 10.95 - 05.04				GAS	210582	MG3049	MG3046			516004
						GAS	211721	TG3047			516001	
2.0 Turbo 2.1 TD, 2.2 HDi	(8B)	10.95 - 05.04 10.95 - 05.04				GAS	210582	MG3049	MG3046			516004
						GAS	211721	TG3047			516001	
3.0 V6 excl.	(8B)	10.95 - 05.04				GAS	210583	MG3051	MG3050			516004
						GAS	211721	TG3047			516001	
1.6, 1.8, 2.0 1.9 D, 1.9 TD, 2.0 HDi	(8E/F)	10.96 - 10.04 10.96 - 10.04				GAS	210582	MG3049	MG3046			516004
						GAS	211721	TG3047			516001	
2.0 Turbo 2.1 TD, 2.2 HDi	(8E/F)	10.96 - 10.04 10.96 - 10.04				GAS	210582	MG3049	MG3046			516004
						GAS	211723	TG3052			516001	
3.0 V6 excl.	(8E/F)	10.96 - 10.04				GAS	210583	MG3051	MG3050			516004
						GAS	211723	TG3052				
2.0, 2.2, 3.0 V6 excl. 2.2 HDi excl.	(8C)	03.97 - 12.04 03.97 - 12.04				GAS	210583	MG3051	MG3050			516004
						GAS	211724	TG3053			516010	

407

	(6D)	05.04 -				GAS	211138	SG3082			
						GAS	211139	SG3083			
	(6E)	05.04 -				GAS	211138	SG3082			
						GAS	211139	SG3083			
	(6C)	10.05 -				GAS	211140	SG3084			
						GAS	211141	SG3085			

504

L, LD > Ch. 2181356		01.73 - 12.76				OIL	200050	C 3031			
						OIL	201710	T 3021			
GL, TI, GLD > Ch. 2181356		07.68 - 12.76				OIL	200050	C 3031			
						OIL	201715	H 3033			
L, LD, GR, GRD, SR, SRD Ch. 2181357 >		01.76 - 12.80									
						OIL	201710	T 3021			
GL, TI, GLD Ch. 2181357 >		01.76 - 12.86									
						OIL	201715	H 3033			
L, GL, LD, GLD > Ch. 2181356		01.72 - 12.76				OIL	200050	C 3031			
						OIL	201711	T 3022			
L, GL, GR, LD, GLD, GRD Ch. 2181357 >		01.76 - 07.86									
						OIL	201711	T 3022			
> Ch. 2085065		01.68 - 12.76				OIL	200050	C 3031			
						OIL	201715	H 3033			

PEUGEOT (F)

Ch. 2085066 >		01.76 - 08.84			/									
					∅	OIL	201715	H 3033						
	(U01, U20)	01.80 - 05.85												
				N.D.	∅	OIL	201712	T 3023						
Ch. 3972016 >	(U01, U20)	06.85 - 12.89			/	OIL	200052	C 3035						
				N.D.	∅	OIL	201712	T 3023						

505

excl. 2.2 Turbo > Ch. 1845000	(551A)	05.79 - 12.85			/									
2.2 Turbo > Ch. 1887751		03.84 - 12.86			∅	OIL	201715	H 3033						
excl. 2.8 V6, 2.2 Turbo Ch. 1845001 >	(551A)	01.86 - 12.93			/	OIL	200053	C 3036						
2.2 Turbo excl. ABS Ch. 1887752 >		01.87 - 12.93			∅	OIL	201715	H 3033						
2.8 V6, 2.2 Turbo ABS Ch. 1965001 >	(551A)	01.87 - 12.93			/									
					∅	OIL	201715	H 3033						
> Ch. 1845000	(551D)	04.82 - 12.85			/									
					∅	OIL	201716	H 3037						
Ch. 1845001 >	(551D)	01.86 - 12.93			/	OIL	200053	C 3036						
					∅	OIL	201716	H 3037						

508

excl. Hybrid excl.		11.10 -				GAS	210600	MG3107	MG3106					516004
						GAS	211142	SG3108						

604

excl. 2.8 GTI	(561A)	01.74 - 07.87			/									
				excl.	∅	OIL	201715	H 3033						

605

excl.	(6B)	10.89 - 09.99				GAS	210581	MG3039	MG3038					516004
					∅	GAS	211717	TG3040						

607

excl.	(9D, 9U)	02.00 -				GAS	210587	MG3065	MG3064					516004
					∅	GAS	211728	TG3063						

806

	(221)	03.94 - 12.97				GAS	210270	MG1366		600741	600742	516004
				18A	∅	GAS	211401	TG1367				
	(221)	01.98 - 08.02				GAS	210270	MG1366		600741	600742	516004
				18B	∅	GAS	211351	TG0944				

807

	(E)	06.02 -				GAS	210447	MG2241	MG2242	600741	600742	516004
					∅	GAS	211289	TG0636				

1007

1.4, 1.6-16V, 1.4 HDI	(KM)	04.05 -				GAS	210212	MG0955	MG0954	600230	516004
					∅	GAS	211353	TG0956			

PEUGEOT (F)

2008

		03.13 -		11A		GAS	210601	MG3109	MG3110			516004
				11B		GAS	210602	MG3113	MG3112			516004
						GAS	211739	TG3111				

3008

	, excl. Hybrid	(OU_)	06.09 -				GAS	210596	MG3093	MG3094			516004
							GAS	211735	TG3095				

4007

	2.4 16V, 2.2 HDi	(GP)	02.07 -				GAS	210225	MG0987	MG0988			516004
							GAS	211358	TG0989				

4008

			05.12 - 08.13				GAS	210538	MG2691	MG2692			516004
							GAS	211121	SG2693				

5008

			09.09 -				GAS	210597	MG3097	MG3096			516004
							GAS	211736	TG3098				

BIPPER

	N.D. Finestrato	(255)	02.08 -				GAS	210173	MG0685	MG0684	600541	600542	516004
							GAS	211305	HG0686				
	H.D. Cassonato	(255)	02.08 -				GAS	210173	MG0685	MG0684	600541	600542	516004
							GAS	212012	HG5314				

BOXER

	1000 Kg, 1400 Kg	(230L)	02.94 - 04.02		15		OIL	200265	M 1355		600071	600072	516007
							GAS	210265	MG1355				
					14D		OIL	201398	H 1356				
							GAS	211398	HG1356				
	1800 Kg	(230L)	02.94 - 04.02		15B		OIL	200280	M 1385		600071	600072	516007
							GAS	210280	MG1385				
					14E		OIL	201405	H 1383				
							GAS	211405	HG1383				
	COMBI	(230P)	02.94 - 04.02		15B		OIL	200265	M 1355		600071	600072	516007
							GAS	210265	MG1355				
		(244)	04.02 - 05.06		15B		OIL	200265	M 1355		600071	600072	516007
							GAS	210265	MG1355				
					14D		GAS	211398	HG1356				
		(244, Z)	04.02 - 05.06										516007
	1000Kg 1400Kg		04.06 -		15Ca		GAS	210881	MG5309		600651	600652	516007
					14F		GAS	211296	HG0655				
	1400Kg 2000Kg		04.06 -		15Ca		GAS	210882	MG5310		600651	600652	516007
					14G		GAS	211301	HG0672				

PEUGEOT (F)

1000Kg 1400Kg REINFORCED		04.06 -		15Cb		GAS	210159	MG0654	600651	600652	516007
				14F		GAS	211296	HG0655			
1400Kg 2000Kg REINFORCED		04.06 -		15Cb		GAS	210167	MG0670	600651	600652	516007
				14G		GAS	211301	HG0672			

EXPERT

(> Ch. 7609)	(222, 223, 224)	07.95 - 12.97				GAS	210270	MG1366	600741	600742	516004
				18A		GAS	211401	TG1367			
(Ch. 7610 > 9793)	(222, 223, 224)	01.98 - 08.2003				GAS	210270	MG1366	600741	600742	516004
				18B		GAS	211351	TG0944			
(Ch. 9794 > 10408)		10.03 - 05.04				GAS	210166	MG0669 MG0668	600741	600742	516004
				18B		GAS	211351	TG0944			
(Ch. 10409 >)		05.04 - 2006				GAS	210270	MG1366	600741	600742	516004
				18B		GAS	211351	TG0944			
1.6D, 2.0 D	(VF3)	01.07 -				GAS	210169	MG0677 MG0676	600741	600742	516004
				18C		GAS	211303	TG0678			
1.6D, 2.0 D H.D.	(VF3)	01.07 -				GAS	210170	MG0679 MG0680	600741	600742	516004
				18D		GAS	211304	TG0681			

J5

Ch. > 0244300	(280L, 280P)	09.81 - 12.85		15A		OIL	200206	M 0932			516004
				14G		OIL	201347	H 0934			
Ch. 0244301 >	(280L, 280P, 290L, 290P)	01.85 - 12.94		15A		OIL	200207	M 0933			516004
				14G		OIL	201347	H 0934			
excl. 1800kg	(280L)	09.81 - 12.84		15A		OIL	200206	M 0932			516004
				14G		OIL	201347	H 0934			
excl. 1800kg	(280L)	01.85 - 12.87		15A		OIL	200207	M 0933			516004
				14G		OIL	201347	H 0934			
excl. 1800kg	(280L, 290L)	01.88 - 12.94		15A		OIL	200207	M 0933			516004
				14B		OIL	201348	H 0935			

J7

		01.66 - 03.80				OIL	201719	H 3043			
						OIL	201718	H 3042			

J9

		03.80 - 12.94				OIL	201719	H 3043			
						OIL	201718	H 3042			

P4

						GAS	211540	HG2512			
						GAS	211541	HG2513			

PARTNER / RANCH

excl. 4X4	(5, 5F)	06.96 - 11.02				GAS	210210	MG0949 MG0948	600110		516004
						OIL	201713	T 3027			
						GAS	211713	TG3027			
	(G)	11.02 -				GAS	210588	MG3067 MG3066	600101	600102	516004
						GAS	211713	TG3027			

PEUGEOT (F)

		04.08 -			GAS	210224	MG0985	MG0984	600090	516004
					GAS	211357	TG0986			

PIAGGIO (I)

PORTER

excl. 16V		1992 -			OIL	200920	M 5603	M 5604		
					OIL	202041	T 5605			
16V		05.98 -			OIL	200920	M 5603	M 5604		
excl. 16V		1992 -			OIL	200919	M 5601	M 5602		
					OIL	202041	T 5605			
16V		05.98 -			OIL	200919	M 5601	M 5602		
maxi, 4WD, 1100 kg, ribaltabile		2002 -			GAS	210922	MG5609	MG5610		
					OIL	202041	T 5605			
euro 5	(D120)	2011 -			GAS	210921	MG5607	MG5606		
					OIL	202042	T 5608			

POLSKI (PL)

100

101 P Zastava					OIL	200243	M 1311			
					OIL	200244	M 1312			

125

		1968 - 1978			OIL	201378	T 1304			

126

					OIL	201380	T 1306			
					OIL	201381	T 1307			

127

					OIL	200240	M 1308			
					OIL	200134	M 0504			

132

					OIL	201378	T 1304			
					OIL	201384	T 1320			

FSO

Polonez 1500, 1600, Atou, Caro		06.78 - 07.93			OIL	201378	T 1304			

PORSCHE (D)

356

A, B, C, SC		01.56 - 12.65			⊗	OIL	201666	H 2911			
					⊕						

924

		11.75 - 12.85			/	GAS	210082	CG4415			
					⊗	GAS	211743	TG3202			

944

		06.81 - 07.84			/	GAS	210082	CG4415			
					⊗	GAS	211743	TG3202			

RENAULT (F)

R 4

	(R112_)	01.61 - 08.68			♂						
					♀	OIL	201745	T 3302			
	(R112_)	09.68 - 12.93			♂	OIL	201746	T 3303			
					♀	OIL	201745	T 3302			
GTL, Rodeo	(R1128)	01.73 - 12.93			♂	OIL	201746	T 3303			
					♀	OIL	201745	T 3302			
	(R2102/4/5/6)	01.61 - 08.68			♂						
					♀						
F4	(R2105/6/8/9) R2391/2)	09.68 - 12.93			♂	OIL	201746	T 3303			
					♀						
F6	(R2340/70) R2430)	01.75 - 12.93					201746	T 3303			

R 5

excl. Alpine		02.72 - 09.84			♂	OIL	201746	T 3303			
					♂	OIL	201748	T 3306			
(R1223/122 B) Alpine	(R1223/122 B)	03.76 - 09.84			♂	OIL	201749	T 3307			
					♂	OIL	201750	T 3308			

SUPER 5

excl. GT Turbo / GTE	(B, C, S)	09.84 - 05.88		35A		OIL	200605	M 3309			516004
					⊗	OIL	201751	T 3310			
excl. GT Turbo, GTE	(B, C, S)	06.88 - 12.96		35A		OIL	200605	M 3309			516004
					⊗	OIL	201751	T 3310			
excl. GT Turbo, GTE	(B, C, S)	06.88 - 12.96		35B		OIL	200606	M 3311			516004
GTE	(C409)	01.87 - 12.96				OIL	200607	M 3313			516004
					⊗	GAS	211752	TG3312			
1.4 GT Turbo	(C405)	09.84 - 07.85									516004
					⊗	GAS	211752	TG3312			
1.4 GT Turbo	(C405)	08.85 - 05.87				OIL	200607	M 3313			516004
					⊗	GAS	211752	TG3312			
1.4 GT Turbo	(C405)	06.87 - 05.91				OIL	200608	M 3314			516004
					⊗	GAS	211752	TG3312			

R 6

	(R1180, R1181)	01.68 - 04.87			♂	OIL	201746	T 3303			
					♀	OIL	201745	T 3302			

R 9

1.1, 1.2, 1.4, 1.6 D	(L 42_)	09.81 - 12.89				OIL	200610	M 3319			516004
				—	♂	OIL	201754	T 3320			
1.7 > Ch. D00000525	(L 42 F/L/N)	09.84 - 12.86				OIL	200610	M 3319			516004
				—	♂	OIL	201754	T 3320			

RENAULT (F)

1.7 > Ch. D00003950, > Ch. H00005600	(L 426)	09.84 - 12.86				OIL	200610	M 3319			516004
				I		OIL	201754	T 3320			
1.7 Ch. D00000526 >	(L 42 F/L/N)	01.86 - 12.88				OIL	200610	M 3319			516004
				II		OIL	201755	T 3321			
1.7 Ch. D00003951 >, Ch. H00005601 >	(L 426)	01.86 - 12.88				OIL	200610	M 3319			516004
				II		OIL	201755	T 3321			
1.7 GTE, 1.4 Turbo	(L 42E, L425)	04.84 - 12.89				OIL	200610	M 3319			516004
				II		OIL	201755	T 3321			

R 11

1.1, 1.2, 1.4, 1.6 D	(B/C/S 37_) 37 S, 37 J)	03.83 - 07.89				OIL	200610	M 3319			516004
				I		OIL	201754	T 3320			
1.7 > Ch. D00043789 > Ch. H00017726 > Ch. D00006418	(B/C 376)	10.83 - 12.86				OIL	200610	M 3319			516004
				I		OIL	201754	T 3320			
1.7 > Ch. D00000644 > Ch. D00000509	(B/C 37 F/L/N)	10.84 - 12.86				OIL	200610	M 3319			516004
				I		OIL	201754	T 3320			
1.4 Turbo > Ch. D00001343 > Ch. D00007886 > Ch. E00002300	(B/C 375)	04.84 - 12.86				OIL	200610	M 3319			516004
				I		OIL	201754	T 3320			
1.7 Ch. D00043790 > Ch. H00017727 > Ch. D00006419 >	(B/C 376)	01.86 - 12.87				OIL	200610	M 3319			516004
				II		OIL	201755	T 3321			
1.7 Ch. D00000645 > Ch. D00000510 >	(B/C 37 F/L/N)	01.86 - 12.88				OIL	200610	M 3319			516004
				II		OIL	201755	T 3321			
1.7	(B 37E, C37E)	01.86 - 12.88				OIL	200610	M 3319			516004
				II		OIL	201755	T 3321			
1.4 Turbo excl. Zender Ch. D00001344 > Ch. D00007887 > Ch. E00002301 >	(B/C 375)	01.86 - 12.88				OIL	200610	M 3319			516004
				II		OIL	201755	T 3321			

R 12

		10.69 - 04.70									
					+	OIL	201756	T 3323			
		05.70 - 08.80				OIL	201143	S 3322			
					+	OIL	201756	T 3323			

R 14

 > Ch. 345946, > Ch. 7533	(R1210, R1211)	05.76 - 12.78				OIL	200023	C 0911			
						OIL	201748	T 3306			

RENAULT (F)

Ch. 345947 >, Ch. 7534 >	(R1210/1/2/3)	01.78 - 12.83			/	OIL	200055	C 3324			
					÷	OIL	201748	T 3306			

R 15

TL, TS	(R1300, R1302)	10.71 - 10.80			/	OIL	201143	S 3322			516010
					+	OIL	201756	T 3323			

R 16

	(R115)	09.65 - 08.80			÷	OIL	201757	T 3325			
					÷	OIL	201758	T 3326			

R 17

TL, TS	(R1301 > R1328)	04.72 - 10.80			/	OIL	201143	S 3322			
					+	OIL	201756	T 3323			

R 18

TS, GTS > Ch. 10709	(R1342)	04.78 - 12.82			/	OIL	201146	S 3330			
					+	OIL	201759	T 3328			
TL, GTL > Ch. 552000 TS, GTS, GTL > Ch. 559400 TS, GTS Ch. 10709 > 20609 TL	(R1340) (R1341) (R1342) (R1349)	04.78 - 12.84			/	OIL	201144	S 3327			
		04.78 - 12.84			+	OIL	201759	T 3328			
		04.78 - 12.82									
TL, GTL Ch. 552001 > TS, GTS, GTL Ch. 559401 > TS, GTS Ch. 20610 >	(R1340) (R1341) (R1342)	01.84 - 07.86			/	OIL	201145	S 3329			
		01.84 - 07.86			+	OIL	201759	T 3328			
TX, GTX > Ch. 3200 TD, GTD > Ch. 190905	(R1343) (R1344)	04.78 - 12.83				OIL	201146	S 3330			
		04.78 - 12.84			+	OIL	201759	T 3328			
TX, GTX Ch. 3201 > TD, GTD Ch. 190906 >	(R1343) (R1344)	01.83 - 07.86			/	OIL	201145	S 3329			
		01.84 - 07.86			+	OIL	201759	T 3328			
1.6 Turbo 2.1 D Turbo	(R1345, R134A) (R1346)	10.80 - 07.86			/	OIL	201145	S 3329			
		11.81 - 07.86			+	OIL	201759	T 3328			
TL > Ch. 122600 LS, TS, GTS, GTL > Ch. 118200 TS, GTS > Ch. 3929 TL > Ch. 200	(R1350) (R1351) (R1352) (R1359)	05.79 - 12.84			/	OIL	201144	S 3327			
		05.79 - 12.83			+	OIL	201759	T 3328			
TL Ch. 122601 > LS, TS, GTS, GTL Ch. 118201 > TS, GTS Ch. 3930 > TL Ch. 201 >	(R1350) (R1351) (R1352) (R1359)	01.84 - 07.86			/	OIL	201145	S 3329			
		01.84 - 07.86									
		01.83 - 07.86			+	OIL	201759	T 3328			
TX, GTX > Ch. 2000 TD, GTD > Ch. 63219	(R1353) (R1354)	05.79 - 12.82			/	OIL	201146	S 3330			
		05.79 - 12.84			+	OIL	201759	T 3328			
TX, GTX Ch. 2001 > TD, GTD Ch. 63220 >	(R1353) (R1354)	01.82 - 07.86			/	OIL	201145	S 3329			
		01.84 - 07.86			+	OIL	201759	T 3328			
1.6 Turbo 2.1 D Turbo	(R1355, R135A-B) (R1356)	09.82 - 07.86			/	OIL	201145	S 3329			
		01.84 - 07.86			+	OIL	201759	T 3328			
Société 1.4 > Ch. 4600	(R2350)	05.79 - 12.83			/	OIL	201144	S 3327			
					+	OIL	201759	T 3328			
Société 1.4 Ch. 4601 >	(R2350)	01.83 - 07.86			/	OIL	201145	S 3329			
					+	OIL	201759	T 3328			

RENAULT (F)

Soci�t� 2.1 D > Ch. 3499	(R2354)	10.81 - 12.83				OIL	201146	S 3330			
						+	OIL	201759	T 3328		
Soci�t� 2.1 D Ch. 3500 >	(R2354)	01.83 - 07.86				OIL	201145	S 3329			
						+	OIL	201759	T 3328		

R 19

excl. 1.8 16V,	(B/C 53, L53)	05.88 - 12.95				GAS	210611	MG3331				
							OIL	200611	M 3331			
				≡			GAS	211761	TG3333			
				≡			OIL	201765	T 3352			
				I			GAS	211760	TG3332			
				I			OIL	201760	T 3332			
1.8 16 V	(B/C 53, L53)	05.88 - 12.95				GAS	210627	MG3390				
							GAS	211761	TG3333			
excl. 1.8 16V	(D53, 853)	07.91 - 06.96				GAS	210611	MG3331				
							OIL	200611	M 3331			
							GAS	211761	TG3333			
							OIL	201765	T 3352			
1.8 16V	(D53, 853)	07.91 - 06.96				GAS	210627	MG3390				
							GAS	211761	TG3333			

R 20

1.6 L, TL, GTL > Ch. 187000	(R1271)	10.75 - 12.80				OIL	201147	S 3334			
							OIL	200612	M 3335		
1.6 L, TL, GTL Ch. 187001 >	(R1271)	01.81 - 12.83				OIL	201148	S 3336			
							OIL	200612	M 3335		
2.0 LS, TS	(R1272)	10.75 - 12.80				OIL	201149	S 3337			
							OIL	200612	M 3335		
2.0 LS, TS 2.2 TX	(R1272)	01.81 - 12.83				OIL	201150	S 3338			
	(R1279)	10.80 - 12.83				OIL	200612	M 3335			
2.0 LS, TS 2.1 D, 2.1 D Turbo	(R1277)	10.80 - 12.83				OIL	201148	S 3336			
	(R1270, R1276)	10.75 - 12.83				OIL	200612	M 3335			

R 21

L, TL, GTL, TS, GTS, RS, TSE	(B/L 48)	03.86 - 06.94				OIL	200613	M 3339			
							OIL	201762	T 3340		
TX, GTX, GTS SD, GSD	(B/L 48)	03.86 - 06.94				OIL	200613	M 3339			
							OIL	201762	T 3340		
RX, TI, TL, GTX, TXE 4X2 RX, TI, GTX, TXE GTX, TXE TD, GTD TBD, TDX 	(B/L 48K) (B/L 483, B/L 489) (L48S) (B/L 486) (B/L 488, 48L)	03.86 - 06.94				OIL	200614	M 3341	M 3342		
							OIL	201762	T 3340		

RENAULT (F)

RX, TI, TL, GTX, TXE 4X2 RX, TI, GTX, TXE TXI 4X2 GTX, TXE TD, GTD GTD TBD, TDX 	(B/L 48 K/Y) (B/L 483, 489) (L48Q) (L48S) (B/L 486) (B/L 48V) (B/L 488, 48L)	03.86 - 06.94				OIL	200615	M 3343	M 3344			
2.0 Turbo incl. 4X4	(L485)	04.87 - 10.93										
Nevada Nevada	(K481, K482) (K48E/F/H/M/N)	03.86 - 08.94				OIL	200613	M 3339				
Societé	(S481/2, S48H)	03.86 - 08.94				OIL	200613	M 3339				
Nevada 4X2	(K480/3/6/8/9) (K48K/V)	03.86 - 08.94				OIL	200614	M 3341	M 3342			
Societé	(S486, S48V)	03.86 - 08.94				OIL	200614	M 3341	M 3342			
Nevada 4X2	(K480/3/6/8/9) (K48K/V)	03.86 - 08.94				OIL	200615	M 3343	M 3344			
Societé	(S486, S48V)	03.86 - 08.94				OIL	200615	M 3343	M 3344			

R 25

excl. 2.7 V6, 2.8 V6 2.7 V6, 2.8 V6 2.8 V6 excl. Auto., 2.4 V6 Turbo	(B298, B29A) (B293, B29F) (B295)	11.83 - 12.93 11.83 - 08.89 06.87 - 12.92 10.84 - 05.90				OIL	201151	S 3346				
2.8 V6 Auto. excl. 2.5 V6 Turbo excl.	(B293, B29F) (B29G)	06.87 - 12.92 01.90 - 12.92				OIL	200616	M 3347				

R 30

excl. 2.1 D Turbo		02.75 - 01.84				OIL	200612	M 3335				
TS TX > Ch. 22200	(R1273, R1275) (R1278)	02.75 - 01.84 1979 - 1980				OIL	201149	S 3337				
TX Ch. 22200 >	(R1278)	1980 - 01.84				OIL	201150	S 3338				
2.1 D Turbo	(R1270)	02.82 - 03.86				OIL	201148	S 3336				

AVANTIME

	(DE0)	09.01 - 05.03				GAS	210660	MG3475	MG3476			516004
						GAS	211821	TG3477				

CAPTURE

		06.13 -				GAS	210969	MG6501	600731	600732	516004
						GAS	212086	TG6502			516010

CLIO I

RENAULT (F)

<ul style="list-style-type: none"> 1.1 RL, RN 1.1 RC 1.2 RL, RN, RT, NRJ 	(B/C/S 571) (3/5 57) (B/C/S 572)	05.90 - 12.93 01.94 - 05.97 05.90 - 05.97		36A		OIL	200617	M 3348			516004
				36D		GAS	210617	MG3348			
						OIL	201764	T 3350			
						GAS	211764	TG3350			
<ul style="list-style-type: none"> 1.2 RL, RN, RT 	(B/C/S 57 A/R)	05.90 - 09.92		36B		OIL	200618	M 3349			516004
				36D		GAS	210618	MG3349			
						OIL	201764	T 3350			
						GAS	211764	TG3350			
<ul style="list-style-type: none"> 1.2 RL, RN, RT excl. Auto. 	(B/C/S 57 A/R)	10.92 - 12.93		36A		OIL	200617	M 3348			516004
				36D		GAS	210617	MG3348			
						OIL	201764	T 3350			
						GAS	211764	TG3350			
<ul style="list-style-type: none"> 1.2 Automatic 1.2 RL, RN, RT 1.2 RL 	(B/C/S 57L) (B57L)	10.92 - 12.93 05.90 - 12.93 01.94 - 05.97		36B		OIL	200618	M 3349			516004
				36D		GAS	210618	MG3349			
						OIL	201764	T 3350			
						GAS	211764	TG3350			
<ul style="list-style-type: none"> 1.2 RL, RN, RT, Be Bop 1.2 RN, RT 1.2 	(B/C/S 57A) (B/C/S 57 R/S) (C/S 572)	01.94 - 05.97 01.94 - 05.97 01.94 - 05.97		36A		OIL	200617	M 3348			516004
				36D		GAS	210617	MG3348			
						OIL	201764	T 3350			
						GAS	211764	TG3350			
<ul style="list-style-type: none"> 1.4 RL, RN, RT, Baccara, Automatic 1.4 RN, RT, Baccara, Automatic 	(B/C 57B) (B/C 573, 57T)	05.90 - 09.92 05.90 - 09.92		36B		OIL	200618	M 3349			516004
				36D		GAS	210618	MG3349			
						OIL	201764	T 3350			
						GAS	211764	TG3350			
<ul style="list-style-type: none"> 1.4 RL, RN, RT, Baccara excl. Auto. 1.4 RN, RT, Baccara excl. Auto. 	(B/C 57B) (B/C 573, 57T)	10.92 - 12.93 10.92 - 12.93		36A		OIL	200617	M 3348			516004
				36D		GAS	210617	MG3348			
						OIL	201764	T 3350			
						GAS	211764	TG3350			
<ul style="list-style-type: none"> 1.4 Automatic 1.4 S 1.4 RTi 	(B/C 57B, C 57T, C 573) (C57B, C57T)	10.92 - 12.93 05.90 - 12.93 05.90 - 12.93		36B		OIL	200618	M 3349			516004
				36D		GAS	210618	MG3349			
						OIL	201764	T 3350			
						GAS	211764	TG3350			
<ul style="list-style-type: none"> 1.4 RL, RN, RT excl. Auto. 1.4 RN, RT, Be Bop excl. Auto. 1.4 RL, RN, RT, Be Bop 1.4 excl. Automatic 	(C57B) (B/C 57T) (B/C/S 57Y/7) (C573) (B/C/S 577)	01.94 - 05.97		36A		OIL	200617	M 3348			516004
				36D		GAS	210617	MG3348			
						OIL	201764	T 3350			
						GAS	211764	TG3350			
<ul style="list-style-type: none"> 1.4 RL, RN, RT 1.4 S, RTi 1.4 Automatic 	(B/5 57B) (C57B) (C 573/57B/57T)	01.94 - 05.97 01.94 - 05.97 01.94 - 05.97		36B		OIL	200618	M 3349			516004
				36D		GAS	210618	MG3349			
						OIL	201764	T 3350			
						GAS	211764	TG3350			
<ul style="list-style-type: none"> 1.7 RT, Baccara 1.8 RT, Baccara 1.8 RT 1.8 RT, Baccara 	(B/C 574) (B/C 57C) (B 57C) (557D, B578)	01.91 - 12.93 01.91 - 12.93 01.94 - 05.97 01.94 - 05.97		36B		OIL	200618	M 3349			516004
				36D		GAS	210618	MG3349			
						OIL	201764	T 3350			
						GAS	211764	TG3350			
<ul style="list-style-type: none"> 1.8 RSi 	(C57 9/E/H)	01.93 - 05.97									516004
						GAS	211778	TG3381			
<ul style="list-style-type: none"> 1.8 16V 	(C575, C57D)	08.91 - 05.97				GAS	210619	MG3351			516004
						GAS	211793	TG3415			

RENAULT (F)

1.9 D 1.9 D	(B/C/S 571, B/S 576) (B/C 57U)	01.91 - 12.93 01.91 - 12.93		36B 36D		OIL	200618	M 3349			516004
						GAS	210618	MG3349			
						OIL	201764	T 3350			
						GAS	211764	TG3350			
1.9 D 3m	(C57I, S57I)	01.94 - 05.97		36A 36D		OIL	200617	M 3348			516004
						GAS	210617	MG3348			
						OIL	201764	T 3350			
						GAS	211764	TG3350			
1.9 D 5 m	(B57I)	01.94 - 05.97		36B 36D		OIL	200618	M 3349			516004
						GAS	210618	MG3349			
						OIL	201764	T 3350			
						GAS	211764	TG3350			
2.0 16V Williams	(C57M)	01.94 - 09.98									516004
				GAS	211779	TG3382					
		05.97 - 03.98		36C		OIL	200633	M 3406			516004
						GAS	210633	MG3406			
						OIL	201764	T 3350			
						GAS	211764	TG3350			

CLIO II

1.2, 1.2 16V	(B/C/BO/1)	03.98 -				OIL	200634	M 3407	600390	516004	
						GAS	210634	MG3407			
						OIL	201788	T 3409			
						GAS	211788	TG3409			
1.4, 1.4 16V, 1.6, 1.5 dCi, 1.9 D, 1.9 dTi	(B/C/BO/1)	03.98 -				OIL	200635	M 3408	600390	516004	
						GAS	210635	MG3408			
						OIL	201788	T 3409			
						GAS	211788	TG3409			
1.6 16V	(CBOT)	03.98 -				GAS	210637	MG3416	600390	516004	
						GAS	211788	TG3409			
2.0 RS	(CBOM)	02.00 -				GAS	210644	MG3434			516004
						GAS	211788	TG3409			
3.0 V6 RS		11.00 -				GAS	210645	MG3435			516004
						GAS	211788	TG3409			

CLIO III

1.2	(BRO/1, CRO/1)	06.05 -				GAS	210655	MG3466	600731	600732	516004
						GAS	211817	TG3467			
1.4, 1.5 D, 1.6	(BRO/1, CRO/1)	06.05 -				GAS	210655	MG3466	600731	600732	516004
						GAS	211817	TG3467			
2.0	(BRO/1, CRO/1)	01.06 -				GAS	210657	MG3469	600731	600732	516004
						GAS	211818	TG3470			
Grantour excl.	(KRO/1)	02.08 -				GAS	210655	MG3466	600731	600732	516004
						GAS	211817	TG3467			

CLIO IV

excl. RS		11.12 -				GAS	210670	MG3497	600731	600732	516004
						GAS	211829	TG3498			
Grandtour		01.13 -				GAS	210670	MG3497	600731	600732	516004
						GAS	211829	TG3498			

RENAULT (F)

ESPACE I

2.0 > Ch. T005812	(J112)	07.84 - 12.84											
						∞	GAS	211766	TG3357				
	(J112, J115, J117)	01.85 - 12.87				∞	OIL	201152	S 3353				
						∞	GAS	211766	TG3357				
excl. □	(J112, J115, J116, J117)	01.88 - 12.90				∞	GAS	211153	SG3354				
						∞	GAS	211766	TG3357				

ESPACE II

excl. 2.8 V6, Quadra 4X4, □	(J63)	01.91 - 10.96				∞	GAS	211153	SG3354				
						∞	GAS	211766	TG3357				
2.8 V6 excl. Quadra 4X4, □	(J638)	01.91 - 10.96				∞	GAS	211155	SG3391				
						∞	GAS	211766	TG3357				

ESPACE III

excl. Grand Espace	(JE)	11.96 - 10.02				∞	GAS	210639	MG3420				516004
					excl.	∞	GAS	211785	TG3401				
Grand Espace	(JE0)	01.97 - 12.02				∞	GAS	210639	MG3420				516004
						∞	GAS	211823	TG3480				

ESPACE IV

	(JK0)	11.02 -				∞	GAS	210649	MG3444				516004
						∞	GAS	211805	TG3445				

EXPRESS / EXTRA / RAPID / COMBI

excl. CU+ (775Kg)	(F40, G40)	07.85 - 09.96				∞	OIL	200609	M 3315				516004
					≡	∞	GAS	211753	TG3316				
excl. CU+ (775Kg)	(F40, G40)	10.96 - 03.98				∞	OIL	200636	M 3410				516004
					≡	∞	GAS	211753	TG3316				
CU+ (775Kg)	(F40, G40)	01.91 - 09.96				∞	OIL	200609	M 3315				516004
					I	∞	GAS	211781	TG3393				
CU+ (775Kg)	(F40, G40)	10.96 - 03.98				∞	OIL	200636	M 3410				516004
					I	∞	GAS	211781	TG3393				

FLUENCE

, excl. Z.E.	(L30_)	02.10 -				∞	GAS	212095	MG6512				516004
						∞	GAS	212096	TG6513				

FUEGO

	(136)	02.80 - 10.85				∞	OIL	201145	S 3329				
		02.80 - 10.85				+	OIL	201759	T 3328				

KADJAR

excl. 4WD	(HA_, HL_)	06.15 -				∞	GAS	210835	MG4905	MG4906			516004
						∞	GAS	211968	TG4907				
4WD	(HA_, HL_)	06.15 -				∞	GAS	210835	MG4905	MG4906			516004
						∞	GAS	211969	TG4908				

KANGOO

RENAULT (F)

excl. Pampa, CU+ (800 Kg)	(KCO, FCO)	04.98 -				OIL	200631	M 3402	600390	516004
						GAS	210631	MG3402		
				≡		OIL	201786	T 3403		
				≡		GAS	211786	TG3403		
Pampa	(KCO, FCO)	04.98 -				OIL	200654	M 3465	600390	516004
						GAS	210654	MG3465		
						OIL	201816	T 3464		
						GAS	211816	TG3464		
CU+ (800 Kg)	(KCO, FCO)	04.98 -				OIL	200631	M 3402	600390 600390	516004
						GAS	210631	MG3402		
				≡		OIL	201815	T 3463		
				≡		GAS	211815	TG3463		
4X4	(KCO, FCO)	10.01 -				GAS	210668	MG3494	600390	516004
						GAS	211828	TG3495		

KANGOO II

incl. Express, Grand Kangoo	(FWO/1)	02.08 -		37A		GAS	210666	MG3492			516004
						GAS	211827	TG3489			
				37B		GAS	210669	MG3496			516004

KOLEOS

2.0 dCi, 2.5 incl 4x4	(HY)	09.08 -				GAS	210665	MG3491	MG3490			516004
						GAS	211826	TG3488				

LAGUNA I

1.6 1.8 RN, RT, RXE 2.0 RT, RXE, Baccara 1.9 dTi	(B56 A/B/S/Z) (B56C, B56H)	11.97 - 03.01 12.93 - 02.95 12.93 - 02.95 10.97 - 03.01		38A		OIL	200628	M 3392			516004
						GAS	210628	MG3392			
						OIL	201780	T 3384			
						GAS	211780	TG3384			
3.0 V6 RT, RTI, Baccara 2.2 D, 2.2 dT RN, RT, RXE	(B56E, B56R) (B56F/B562)	12.93 - 03.01		38A		OIL	200628	M 3392			516004
						GAS	210628	MG3392			
						OIL	201780	T 3384			
						GAS	211780	TG3384			
1.6 1.8 RN, RT, RXE 1.8 RN, RT excl. ABS 2.0 excl. ABS, Auto.	(B56 A/B/S/Z) (B56 T/O) (B56 L/C/H)	11.97 - 03.01 02.95 - 03.01 02.95 - 03.01 02.95 - 03.01		38B		OIL	200623	M 3383			516004
						GAS	210623	MG3383			
						OIL	201780	T 3384			
						GAS	211780	TG3384			
1.8 RN, RT ABS 2.0 ABS, Auto. 2.0 RN, RT, RXE, RTI 2.0 ABS	(B56 T/O) (B56L) (B56 D/M) (B56 C/H)	02.95 - 03.01		38A		OIL	200628	M 3392			516004
						GAS	210628	MG3392			
						OIL	201780	T 3384			
						GAS	211780	TG3384			
Nevada excl. 3.0 V6,	(K56)	09.95 - 03.01		38A		OIL	200628	M 3392			516004
						GAS	210628	MG3392			
					excl.		OIL	201787	T 3404		
					excl.		GAS	211787	TG3404		

RENAULT (F)

Nevada 3.0 V6 - excl.	(K56)	02.96 - 03.01		38A		OIL	200628	M 3392			516004
						GAS	210628	MG3392			
					excl.						

LAGUNA II

	(B60/1)	03.01 -				GAS	210643	MG3433			516004
						GAS	211798	TG3428			
	(K60/1)	03.01 -				GAS	210643	MG3433			516004
						GAS	211799	TG3429			

LAGUNA III

	(B70/1, K70/1)	10.07 -				GAS	210662	MG3481			516004
						GAS	211824	TG3482			

LATITUDE

	(L70)	07.10 -				GAS	210970	MG6503	MG6504			516004
						GAS	212087	TG6505				

MASTER Q-SERIES

	(T_, P_)	05.80 - 03.98				OIL	201774	H 3366			
						OIL	201772	H 3364			

MASTER R-SERIES

(R2, R4)	(T_)	05.80 - 03.98				OIL	201774	H 3366			
						OIL	201773	H 3365			
(R3) excl. Minicar	(T_)	05.80 - 03.98				OIL	201774	H 3366			
						OIL	201774	H 3366			
(R3) Minicar	(T_)	05.80 - 02.89				OIL	201774	H 3366			
						OIL	201774	H 3366			
(RC/RD/RL 9)	(P_)	05.80 - 03.98				OIL	201774	H 3366			
						OIL	201772	H 3364			
excl. Minicar	(T_)	03.89 - 03.98				OIL	201774	H 3366			
						OIL	201773	H 3365			
Minicar	(T_)	03.89 - 03.98				OIL	201774	H 3366			
						OIL	201774	H 3366			

MASTER II

2,8T	(FD, JD)	07.98 -				GAS	211789	HG3411					
						GAS	211789	HG3411					
			3T, 3,5T	(ED, FD, JD)	07.98 -				OIL	201790	H 3412		
									GAS	211790	HG3412		
3,5T	(HD, UD)	07.98 -				GAS	211789	HG3411					
						OIL	201791	H 3413					

MASTER III

excl.	(EV, FV, HV, JV, UV)	05.10 -				GAS	210875	MG5221			516007
						GAS	212006	HG5222			
excl.	(EV, FV, HV, JV, UV)	05.10 -				GAS	210875	MG5221			516004
						GAS	212007	HG5223			
incl.	(EV, FV, HV, JV, UV)	05.10 -					212118	MG5231			516007
						GAS	212008	HG5224			

RENAULT (F)

MÉGANE I

Classic excl. 2.0 16V	(BA)	09.95 - 12.02				OIL	200629	M 3394			516004
						GAS	210629	MG3394			
						GAS	211782	TG3395			
2.0 16V	(BA)	09.95 - 12.02				GAS	210630	MG3397			516004
						GAS	211784	TG3398			
	(KA)	01.98 - 06.99				OIL	200629	M 3394			516004
						GAS	210629	MG3394			
						GAS	211796	TG3423			
	(KA)	07.99 -				GAS	210629	MG3394			516004
						GAS	211796	TG3423			
excl. 2.0, 2.0 16V	(DAO/1)	10.96 - 12.02				OIL	200629	M 3394			516004
						GAS	210629	MG3394			
						GAS	211782	TG3395			
2.0, 2.0 16V	(DAO/1)	10.96 - 10.98				GAS	210630	MG3397			516004
						GAS	211784	TG3398			
2.0, 2.0 16V	(DAO/1)	11.98 - 12.02				GAS	210641	MG3425			516004
						GAS	211784	TG3398			
excl. 2.0, 2.0 16V	(EAO)	10.96 - 12.02				OIL	200629	M 3394			516004
						GAS	210629	MG3394			
						GAS	211784	TG3398			
2.0, 2.0 16V	(EAO)	10.96 - 10.98				GAS	210630	MG3397			516004
						GAS	211797	TG3424			
2.0, 2.0 16V	(EAO)	11.98 - 12.02				GAS	210641	MG3425			516004
						GAS	211797	TG3424			

MÉGANE II

1.4, 1.6, 2.0, 1.5 dCi, 1.9 dCi excl.	(BMO/1, CMO/1)	11.02 - 01.11				GAS	210650	MG3449	600200		516004
						GAS	211812	TG3459			
	(BMO/1, CMO/1)	11.02 - 01.11				GAS	211806	TG3450			
						GAS	210650	MG3449	600200		516004
1.4, 1.6, 2.0 excl.	(LMO/1)	09.03 -				GAS	210650	MG3449	600200		516004
						GAS	211812	TG3459			
1.5 dCi, 1.9 dCi excl.	(LMO/1)	09.03 -				GAS	210652	MG3458			516004
						GAS	211812	TG3459			
Grandtour 1.4, 1.6, 2.0 excl.	(KMO/1)	09.03 - 08.09				GAS	210650	MG3449	600200		516004
						GAS	211807	TG3451			
Grandtour 1.5 dCi, 1.9 dCi excl.	(KMO/1)	09.03 - 08.09				GAS	210652	MG3458			516004
						GAS	211807	TG3451			
1.6, 2.0, 1.5 dCi, 1.9 dCi	(EMO/1)	09.03 - 08.09				GAS	210652	MG3458			516004
						GAS	211807	TG3451			

MÉGANE III

	(BZO/1, DZO/1, KZO/1)	10.08 -				GAS	210663	MG3483			516004
						GAS	211825	TG3484			

MODUS

RENAULT (F)

	(F/JPO)	12.04 -				GAS	210653	MG3461	600731	600732	516004
							GAS	211814	TG3462		

SAFRANE

excl. 4X4, 1 st	(B54)	04.92 - 12.00				GAS	210624	MG3385	MG3386		516004
							GAS	210625	MG3387		

SANDERO/STEPWAY I

		11.07 -				GAS	210955	MG6209			516004
							GAS	212074	TG6210		

SCÉNIC I

1.4 1.6 excl. Auto.	(JAO/1)	11.96 - 06.98				OIL	200629	M 3394			516004	
							GAS	210629	MG3394			
							GAS	211783	TG3396			
1.6 Auto., 2.0 1.9 D, 1.9 dT, 1.9 dTi	(JAO/1)	11.96 - 06.98				OIL	200632	M 3405			516004	
							GAS	210632	MG3405			
							GAS	211783	TG3396			
excl. RX4	(JAO/1)	06.98 - 06.03				OIL	200629	M 3394			516004	
							GAS	210629	MG3394			
							GAS	211783	TG3396			
RX4 4X4	(JAO/1)	07.00 - 06.03				GAS	210646	MG3438			516004	
							GAS	211802	TG3439			

SCÉNIC II

excl.	(JMO/1)	06.03 -				GAS	210651	MG3453	600200		516004
							GAS	211808	TG3452		
Grand Scénic	(JMO/1)	04.04 -				GAS	210651	MG3453	600200		516004
							GAS	211809	TG3455		

SCÉNIC III

excl. Grand Scénic	(JZO/1)	02.09 -				GAS	210667	MG3493			516004
							GAS	211825	TG3484		
Grand Scénic	(JZO/1)	02.09 -				GAS	210667	MG3493			516004

THALIA

1.4, 1.4 16V, 1.6 16V, 1.5dCi		01.01 -				GAS	210635	MG3408	600390		516004	
							OIL	201788	T 3409			516010
							GAS	211788	TG3409			

TRAFIC P-SERIES (RWD)

P 3 1000kg P 5/6/8 Microcar		09.80 - 02.89				OIL	200620	M 3367	M 3368		516007
		09.80 - 02.89									

TRAFIC T-SERIES (FWD)

T 1 800kg excl. > Ch. 25270 T 1, T2 T 4, T 5B		09.80 - 02.89				OIL	200620	M 3367	M 3368		516007
		03.89 - 03.01					OIL	201775	H 3372		
T 3 1000kg > Ch. 25270 T 4 1000kg excl. > Ch. 25270		09.80 - 02.89				OIL	200620	M 3367	M 3368		516007
		03.89 - 03.01					OIL	201775	H 3372		

RENAULT (F)

T 1 800kg , T 4 1000kg , T 5		09.80 - 02.89				OIL	200620	M 3367	M 3368			516007
							OIL	201776	H 3373			
T 53, TE		03.89 - 03.01				OIL	200620	M 3367	M 3368			516007
							OIL	201776	H 3373			
T 6, T 9 1200kg T 7, TB		01.83 - 12.86 01.86 - 03.01				OIL	200620	M 3367	M 3368			516007
							OIL	201776	H 3373			
T A 1200kg		09.80 - 12.86				OIL	200620	M 3367	M 3368			516007
T 4 1000kg lifted body + Ch. 25271>		01.83 - 02.89										516007
							OIL	201775	H 3372			

TRAFIC II

	(JL, FL)	09.01 -				GAS	210648	MG3442	600150	516007
							GAS	211804	TG3443	

TRAFIC III

	(FG, EG)	05.14 -				GAS	212110	MG6510		516007
							GAS	212111	TG6511	

TWINGO

	(C06)	03.93 - 08.00		34A 36D		OIL	200626	M 3388			516004
						GAS	210626	MG3388			
						OIL	201154	S 3389			
						GAS	211154	SG3389			
	(C06)	09.00 - 08.04				GAS	210642	MG3431	MG3432		516004
							GAS	211154	SG3389		

TWINGO II

	(CNO)	03.07 -				GAS	210661	MG3478	600390	516004
							GAS	211822	TG3479	

TWINGO III

		09.14 -				GAS	210671	MG3499		516004
							GAS	212094	TG6500	

WIND

	(E4M)	07.10 -				GAS	210971	MG6506		
							GAS	212088	TG6507	

VEL SATIS

	(BJO)	06.02 -				GAS	210647	MG3440		
							GAS	211803	TG3441	

ZOE

		06.12 -				GAS	210972	MG6508		
							GAS	212089	TG6509	

ROVER (GB)

25

excl. ZR, Streetwise	(RF)	10.99 - 05.05				GAS	210676	MG3523			516004
						GAS	211159	SG3515			

45

1.4, 1.6, 1.8, 2.0, 2.0 iDT excl. 2.5 ZS	(RT)	02.00 - 05.05				GAS	210378	MG1649	MG1650			516004
						GAS	211069	SG1671				

75

	(RJ)	02.99 - 05.05				GAS	210675	MG3521	MG3522			516004
						GAS	211833	TG3520				516010

100

	(XP)	11.89 - 12.98				OIL	201270	T 0408			

200

213, 216	(XH)	06.84 - 09.89				GAS	210355	MG1611			516004
						GAS	211059	SG1612			
214, 216 216 GTi, 220 GTi 218 D, 218 TD > Ch. 605481	(XW)	10.89 - 10.95				GAS	210364	MG1623	MG1624		516004
			10.89 - 10.92				GAS	210365	MG1625		
218 D, 218 TD Ch. 605482 >	(XW)	10.92 - 10.95				GAS	210364	MG1623	MG1624		516004
						GAS	210365	MG1625			516004
214	(XW)	10.92 - 12.95				GAS	210364	MG1623	MG1624		516004
						GAS	210365	MG1625			516004
216	(XW)	10.92 - 12.95				GAS	210364	MG1623	MG1624		516004
						GAS	210365	MG1625			516004
211, 214, 216 220 D, SD, SDi	(RF)	10.95 - 03.00				GAS	210364	MG1623	MG1624		516004
						GAS	211159	SG3515			
218 200Vi	(RF)	10.95 - 03.00									516004
						GAS	211159	SG3515			

400

414, 416 418 D > Ch. 605481	(XW)	10.89 - 04.95				GAS	210364	MG1623	MG1624		516004
			10.89 - 10.92				GAS	210365	MG1625		
420 GSi, 420 SLi 418 D Ch. 605482 >	(XW)	10.92 - 04.95				GAS	210364	MG1623	MG1624		516004
			10.89 - 04.95				GAS	210365	MG1625		
414, 416	(RT)	05.95 - 03.00				GAS	210378	MG1649	MG1650		516010
						GAS	210365	MG1625			516004
420, 420 D, 420 Di	(RT)	05.95 - 03.00				GAS	210378	MG1649	MG1650		516010
						GAS	211069	SG1671			516010
Tourer 416 > Ch. 911247	(XW)	10.94 - 02.96				GAS	210364	MG1623	MG1624		516004
						GAS	210365	MG1625			516004
Tourer 418 D > Ch. 911247 Tourer 420	(XW)	10.94 - 02.96				GAS	210364	MG1623	MG1624		516004
						GAS	210365	MG1625			516004
Tourer Ch. 911248 >	(XW)	03.96 - 03.00				GAS	210364	MG1623	MG1624		516004
						GAS	210365	MG1625			516004

ROVER (GB)

600

excl. 2.0 Turbo, 2.0 D, 2.0 DI > Ch. AM246796	(RH)	04.93 - 02.96				GAS	210350	MG1606			516004
						GAS	210351	MG1607			516004
excl. 2.0 Turbo, 2.0 D, 2.0 DI Ch. AM246796 >	(RH)	02.96 - 02.99				GAS	210350	MG1606			516004
						GAS	210351	MG1607			516004
2.0 Turbo, 2.0 D, 2.0 DI	(RH)	02.96 - 02.99									

800

		05.86 - 10.91				GAS	211157	SG3501			
						GAS	210672	MG3502			516004
		11.91 - 02.99				GAS	211158	SG3513			
				excl.		GAS					516004

MGF

1.6, 1.8	(RD)	03.95 - 03.02				GAS	211831	TG3518			
						GAS	211832	TG3519			

SD1

2000, 2300, 2600, 3500, 2400 Turbo D excl. Vitesse susp.	(SD1)	06.76 - 12.87				OIL	200056	C 3505			
						GAS					

SAAB (S)

90

🚗 > Ch. G6000885		01.60 - 09.84			⊗	OIL	201666	H 2911			
					⊕	OIL	201834	T 3601			
🚗 Ch. G6000886 >		10.84 - 08.87									
					⊕	OIL	201834	T 3601			

93 / 95 / 96 / 97

93, 93 B		01.56 - 12.59			⊗	OIL	201666	H 2911			
					⊗	GAS	211367	HG1210			
🚗 95		10.65 - 12.78			⊗	OIL	201666	H 2911			
🚗 96 GT 750, 850, 896 sport Sonett 97 sport		10.65 - 08.80			⊗	OIL	201666	H 2911			
		01.60 - 12.66 01.67 - 12.74			⊕	GAS	211835	TG3602			

99

🚗, 🚗 Combi Coupe 1.7, 1.8, 2.0 🚗, 🚗 2.0 Turbo, GLE		11.67 - 04.78			⊗	OIL	201666	H 2911			
		10.77 - 04.78			+	OIL	201240	T 0120			
🚗, 🚗 Combi Coupe 2.0, 2.0 Turbo		05.78 - 01.87			⊗	OIL	201666	H 2911			
					⊕	OIL	201834	T 3601			516010

9-3

🚗	(YS3D)	02.98 - 09.02			/	GAS	210057	CG3620			516004
		02.98 - 08.03			⊕	GAS	211838	TG3610			516010
🚗 excl. 🚗	(YS3F)	09.02 - 02.15			🚗	GAS	210680	MG3615	MG3616	600770	516004
		08.03 - 02.15			⊕	GAS	211839	TG3617			516010

9-5

🚗 2.0, 2.3, 3.0 V6 🚗 Aero 2.3 Turbo	(YS3E)	09.97 - 09.01			🚗	GAS	210679	MG3613	MG3614		516004
		09.97 - 09.01			🚗	GAS	211160	SG3612			
🚗 2.0, 2.3, 3.0 V6 🚗 Aero 2.3 Turbo	(YS3E)	10.98 - 09.01			🚗	GAS	210679	MG3613	MG3614		516004
		10.98 - 09.01			🚗	GAS	211160	SG3612			
🚗 excl. 🚗		09.01 -			🚗	GAS	210681	MG3619	MG3618		516004
					🚗	GAS	211160	SG3612			

900 I

🚗, 🚗 Combi Coupe, 🚗 C, GL, GLS, GLi		06.78 - 12.93			⊕	OIL	201836	T 3603			516004
					⊕	OIL	201834	T 3601			516010
🚗, 🚗 Combi Coupe, 🚗 EMS, GLE, Turbo, Turbo 16, CD		06.78 - 12.93			⊕	GAS	211836	TG3603			516004
					⊕	GAS	211834	TG3601			516010
🚗, 🚗 Combi Coupe, 🚗 Turbo 16, Turbo 16 Aero excl. 16 S sport		01.84 - 12.93		39	⊕	GAS	211836	TG3603			516004
					⊕	GAS	211834	TG3601			516010
🚗, 🚗 Combi Coupe, 🚗 Turbo 16, Turbo 16 Aero excl. 16 S sport		01.84 - 12.93			⊕						516004
					⊕	GAS	211834	TG3601			516010

900 II

🚗		07.93 - 02.98			/	GAS	210058	CG3621			516004
					⊕	GAS	211838	TG3610			516010

SAAB (S)

9000

> Ch. H 8000555		09.84 - 12.87				GAS	210677	MG3606			516004
> Ch. H 1015469				excl.		GAS	211837	TG3608			516010
Ch. H 1015470 >		01.87 - 12.98				GAS	210678	MG3607			516004
Ch. H 8000556 >				excl.		GAS	211837	TG3608			516010

SEAT (E)

124

		1967 -			1/2	OIL	201375	T 1301			
					1/2	OIL	201376	T 1302			
		01.70 - 12.76			1/2	OIL	201375	T 1301			
					∞	OIL	201377	T 1303			

127 / FURA

	(127A, 025A)	04.72 - 12.82				OIL	200240	M 1308			
						OIL	200134	M 0504			
		01.82 -									
						OIL	200134	M 0504			

128

		01.69 - 12.80				OIL	200243	M 1311			
						OIL	200244	M 1312			

131

		12.78 -		12A		OIL	200245	M 1313			
					1/2	OIL	201376	T 1302			
		01.78 - 09.81		12B		OIL	200246	M 1314			
					1/2	OIL	201376	T 1302			
		10.81 -		12C		OIL	200247	M 1315			
					1/2	OIL	201376	T 1302			
		12.78 -		12D		OIL	200248	M 1316			
					1/2	OIL	201376	T 1302			
		01.79 - 09.81		12E		OIL	200249	M 1317			
					1/2	OIL	201376	T 1302			
		12.78 -		12A		OIL	200245	M 1313			
					∞	OIL	201383	T 1319			
		01.79 - 09.81		12B		OIL	200246	M 1314			
					∞	OIL	201383	T 1319			
		10.81 -		12C		OIL	200247	M 1315			
					∞	OIL	201383	T 1319			
		01.79 - 09.81		12E		OIL	200249	M 1317			
					∞	OIL	201383	T 1319			

132

		01.73 - 12.82			1/2	OIL	201378	T 1304			
					1/2	OIL	201384	T 1320			

ALHAMBRA

	(7V8, 7V9)	04.96 - 03.10				GAS	210314	MG1478	600800	516004
					∞	GAS	211429	TG1479		
	(710)	06.10 -				GAS	210776	MG4455	600430	516004
					1/2	GAS	211916	TG4456		

SEAT (E)

ALTEA/ALTEA XL

excl. , 4X4	(5P)	04.04 -		5A		GAS	210776	MG4455	600430	516004
				5B		GAS	210127	MG0343		
						GAS	211916	TG4456		516010
, excl. 4X4	(5P)	04.04 -		5A		GAS	210777	MG4457	600430	516004
				5B		GAS	210128	MG0345		
						GAS	211260	TG0344		516010

AROSA

	(6H)	05.97 - 06.04		40C		OIL	200771	M 4432	600050	516004
						GAS	210771	MG4432		
						OIL	201841	T 3714		516010
						GAS	211841	TG3714		

CORDOBA I

excl. 1.8 16V, 2.0 GTI > Ch. 6K#TR80000	(6K2, C2)	02.93 - 12.95		40A		OIL	200768	M 4410	600040	516004
						GAS	210768	MG4410		
						OIL	201161	S 3710	600700	
						GAS	211161	SG3710		
excl. 1.8 16V, 2.0 GTI Ch. TR80001> 6K#X#400.000	(6K2, C2)	01.96 - 08.99		40A		OIL	200768	M 4410	600040	516004
						GAS	210768	MG4410		
						OIL	201161	S 3710	600700	
						GAS	211161	SG3710		
1.8 16V, 2.0 GTI > Ch. 6K-ZR082400 > Ch. 6K-ZR599964	(6K2, C2)	10.93 - 08.99		40A		GAS	210768	MG4410	600040	516004
						OIL	201162	S 3711		
						GAS	211162	SG3711		
1.8 16V, 2.0 GTI Ch. 6K-ZR082401> Ch. 6K-ZR599965>	(6K2, C2)	10.93 - 08.99		40B		GAS	210769	MG4411	600040	516004
						OIL	201162	S 3711		
						GAS	211162	SG3711		

CORDOBA II

excl. 1.8 20V Turbo Ch. 6K#X#400.001 >	(6K2)	03.99 - 10.02		40B		GAS	210769	MG4411	600040	516004
						OIL	201163	S 3718		
						GAS	211163	SG3718		
1.8 20V Turbo	(6K2)	03.99 - 10.02		40B		GAS	210769	MG4411	600040	516004
						GAS	211163	SG3718		

CORDOBA VARIO

Vario	(6K5)	08.96 - 08.02		40A		OIL	200768	M 4410	600040	516004
						GAS	210768	MG4410		
						OIL	201163	S 3718	600700	
						GAS	211163	SG3718		

CORDOBA III

excl. 1.8 20V Turbo excl.	(6L2)	10.02 - 11.09		N.D. 4A		OIL	200688	M 3715	600350	516004
				N.D. 4A		GAS	210688	MG3715		
						GAS	210126	MG0330		516010
						GAS	211847	TG3811	600290	

SEAT (E)

excl. 1.8 20V Turbo	(6L2)	10.02 - 11.09		4B		GAS	210126	MG0330	600290	516004
						GAS	211842	TG3716		516010

EXEO

excl.	(3R2)	12.08 -			GAS	211012	SG0346	600760	516010
					GAS	211261	TG0347		
excl.	(3R5)	06.09 -			GAS	211012	SG0346	600760	516010
					GAS	211261	TG0347		

IBIZA I

> Ch. 9146536	(021A)	06.84 - 05.86			OIL	200682	M 3701	600570	516004
					GAS	210683	MG3702	516004	
Ch. 9146537 >	(021A)	06.86 - 08.89			OIL	200684	M 3703		516004
					GAS	210684	MG3703		516004
					GAS	210683	MG3702		516004
	(021A)	09.89 - 12.93			OIL	200685	M 3704		516004
					GAS	210685	MG3704		516004
					GAS	210683	MG3702		516004

IBIZA II

excl. 1.8 16V, 2.0 GTI > Ch. 6K#TR80000	(6K1)	02.93 - 12.95		40A		OIL	200768	M 4410	600040	516004
						GAS	210768	MG4410		
						OIL	201161	S 3710	600700	
						GAS	211161	SG3710		
excl. 1.8 16V, 2.0 GTI Ch. TR80001 > 6K#X#400.000	(6K1)	01.96 - 08.99		40A		OIL	200768	M 4410	600040	516004
						GAS	210768	MG4410		
						OIL	201161	S 3710	600700	
						GAS	211161	SG3710		
1.8 16V, 2.0 GTI > Ch. 6K-ZR082400 > Ch. 6K-ZR599964	(6K1)	10.93 - 03.99		40A		GAS	210768	MG4410	600040	516004
						OIL	201162	S 3711	600700	
						GAS	211162	SG3711		
1.8 16V, 2.0 GTI Ch. 6K-ZR082401 > Ch. 6K-ZR599965 >	(6K1)	10.93 - 03.99		40B		GAS	210769	MG4411	600040	516004
						OIL	201162	S 3711	600700	
						GAS	211162	SG3711		

IBIZA III

excl. 1.8 20V Turbo Ch. 6K#X#400.001>	(6K1)	03.99 - 02.02		40B		GAS	210769	MG4411	600040	516004
						OIL	201163	S 3718	600700	
						GAS	211163	SG3718		
1.8 20V Turbo	(6K2)	03.99 - 10.02		40B		GAS	210769	MG4411	600040	516004
						GAS	211163	SG3718	600700	

IBIZA IV

excl. 1.8 20V Turbo excl.	(6L1)	02.02 - 11.09		N.D. 4A		OIL	200688	M 3715	600350	516004
				N.D. 4A		GAS	210688	MG3715		
				H.D. 4B		GAS	210126	MG0330		
						GAS	211847	TG3811	600290	516010
excl. 1.8 20V Turbo 	(6L1)	02.02 - 11.09		4B		GAS	210126	MG0330	600350	516004
						GAS	211842	TG3716	600290	516010

SEAT (E)

IBIZA V

	(6J5)	03.08 -				GAS	210689	MG3719	600270	516004
							GAS	211843	TG3720	600290
	(6J8)	03.10 -				GAS	210689	MG3719	600270	516004
							GAS	211843	TG3720	600290
	(6J1)	07.08 -				GAS	210689	MG3719	600270	516004
							GAS	211843	TG3720	600290

INCA

	(6K9)	11.95 - 06.09		40C		OIL	200771	M 4432	600050	516004
							GAS	210771		
							GAS	211840	TG3713	

LEON I

1.4 16V, 1.6, 1.6 16V, 1.9 SDI excl.	(1M1)	10.98 - 06.06		4A		OIL	200772	M 4441	600270	516004
							GAS	210772		
							GAS	211252	TG0320	600290
1.8, 2.3, 1.9 TDI excl. 1.8 Turbo,	(1M1)	10.98 - 06.06		4B		OIL	200124	M 0316	600270	516004
							GAS	210124		
							GAS	211252	TG0320	600290

LEON II

excl.	(1P1)	09.05 - 12.12		5A		GAS	210776	MG4455	600430	516004
				5B			GAS	210127		
				GAS			211916	TG4456		516010
	(1P1)	09.05 - 12.12		5A		GAS	210777	MG4457	600430	516004
				5B			GAS	210128	MG0345	
				GAS			211260	TG0344		516010

LEON III

excl. Cupra,	(5F1)	09.12 -		5A		GAS	210785	MG4474		516004
				5B			GAS	210784		
				GAS			211924	TG4472		516010

LEON IV

SC excl.	(5F5)	01.13 -		5B		GAS	210784	MG4471		516004
				5A			GAS	210785		
				GAS			211924	TG4472		516010
ST excl.	(5F8)	08.13 -		5B		GAS	210784	MG4471		516004
				5A			GAS	210785		
				GAS			211924	TG4472		516010

MALAGA / CREDOS

> Ch. 9071599		11.84 - 08.86				OIL	200682	M 3701	600570	
Ch. 9071600 >	(023A)	09.86 - 08.89					OIL	200684	M 3703	
						GAS	210684	MG3703		
							GAS	210683	MG3702	

SEAT (E)

		09.89 - 12.93				OIL	200685	M 3704		
						GAS	210685	MG3704		
						GAS	210683	MG3702		

MARBELLA

	(28, 28A)	08.86 - 03.89				GAS	210255	MG1333	600570	516004
						OIL	200255	M 1333		
						OIL	201390	T 1334		
		04.89 - 10.98				OIL	200687	M 3708		516004
						OIL	201390	T 1334		

MII

	(KF1)	10.11 -				GAS	210783	MG4469	600270	516004
						GAS	211923	TG4470		516010

PANDA

	(141A)	10.80 - 12.86				OIL	200255	M 1333	600570	516004
						GAS	210255	MG1333		
						OIL	201390	T 1334		

RONDA / RITMO

	(022A, 138)	07.78 - 09.83				OIL	200256	M 1335	600570	516004	
						GAS	210256	MG1335			
						GAS	210683	MG3702			
	excl. Crono	(022A, 138)	10.83 - 03.86				OIL	200682	M 3701	600570	516004
							GAS	210683	MG3702		
	excl. Crono	(022A, 138)	05.86 - 11.88				OIL	200684	M 3703		516004
							GAS	210684	MG3703		
							GAS	210683	MG3702		
	Crono	(022A, 138)	10.83 - 03.86				OIL	200682	M 3701	600570	516004
							GAS	210683	MG3702		

TERRA

	(024, 024A)	01.87 - 03.89				OIL	200255	M 1333	600570	516004
						GAS	210255	MG1333		
						OIL	201390	T 1334		
	(024, 024A)	04.89 - 12.96				OIL	200687	M 3708		516004
						OIL	201390	T 1334		

TOLEDO I

	1.6, 1.9 D, 1.9 TD, 1.9 TDI	(1L)	01.91 - 12.92		40A		OIL	200768	M 4410	600040	516004
							GAS	210768	MG4410		
								OIL	201174	S 4404	600700
	1.6, 1.9 D, 1.9 TD, 1.9 TDI	(1L)	01.93 - 10.99		40A		OIL	200768	M 4410	600040	516004
							GAS	210768	MG4410		
								OIL	201174	S 4404	600700
	1.8, 1.8 16V, 2.0, 2.0 16V	(1L)	01.91 - 12.92		40D		GAS	210767	MG4409	600040	516004
							GAS	211174	SG4404	600700	

SEAT (E)

1.8, 1.8 16V, 2.0, 2.0 16V	(1L)	01.93 - 10.99		40D		GAS	210767	MG4409	600040	516004
						GAS	211174	SG4404	600700	

TOLEDO II

1.4 16V, 1.6, 1.6 16V 1.9 SDI Excl. ,	(1M2)	04.99 - 05.06		4A		OIL	200772	M 4441	600270	516004
						GAS	210772	MG4441		
						GAS	211251	TG0317	600290	516010
1.8, 2.3 V5, 1.9 TDI Excl. 1.8 Turbo, ,	(1M2)	04.99 - 05.06		4B		OIL	200124	M 0316	600270	516004
						GAS	210124	MG0316		
						GAS	211251	TG0317	600290	516010

TOLEDO III

excl.	(5P2)	04.04 - 05.09		5A		GAS	210776	MG4455	600430	516004
				5B		GAS	210127	MG0343		
					GAS	211916	TG4456		516010	
	(5P2)	04.04 - 05.09		5A		GAS	210777	MG4457	600430	516004
				5B		GAS	210128	MG0345		
					GAS	211260	TG0344		516010	

TOLEDO IV

	(KG3)	07.12 -				GAS	210689	MG3719	600270	516004
						GAS	211843	TG3720	600290	516010

TRANS

		01.85 - 12.96				OIL	200255	M 1333	600570	516004
						GAS	210255	MG1333		
						OIL	201390	T 1334		

SKODA (CS)

100 SERIES

100, 105, 110, 120	(742, 744)	01.70 - 12.90			⊖						
					+	OIL	201845	T 3802			
130, 130, Rapid		04.81 - 10.91			⊖						
135		11.88 -			⊖						
					+	OIL	201845	T 3802			

1000 SERIES

excl.		09.64 - 01.70			⊖						
					+	OIL	201845	T 3802			
Octavia		01.67 - 01.70			⊖						

CITIGO

		10.11 -				GAS	210783	MG4469	600270	516004
					⊖	GAS	211923	TG4470		516010

FABIA

1.0, 1.4, 1.4 16V, 2.0, 1.9 SDI excl.	(6Y2, 6Y3, 6Y5)	12.99 - 03.08		4A		OIL	200694	M 3810	600350	516004
						GAS	210694	MG3810		
						⊖	GAS	211847	TG3811	600290
1.4 TDI, 1.9 TDI excl.	(6Y2, 6Y3, 6Y5)	12.99 - 03.08		4A		OIL	200688	M 3715	600350	516004
						GAS	210688	MG3715		
						⊖	GAS	211842	TG3716	600290
	(542)	12.06 - 12.14		4A		GAS	210688	MG3715	600350	516004
						⊖	GAS	211847		
Combi	(545)	10.07 - 12.14		4A		GAS	210688	MG3715	600350	516004
						⊖	GAS	211842		
excl.	(NJ3)	08.14 -				GAS	210689	MG3719	600270	516004
						⊖	GAS	211843		
excl.	(NJ5)	10.14 -				GAS	210689	MG3719	600270	516004
						⊖	GAS	211843		

FAVORIT

excl.	(781)	05.89 - 09.94				OIL	200690	M 3803		516004
						OIL	201164	S 3804	600700	516010

FELICIA

, , excl. ABS	(6U1, 6U5, 797)	10.94 - 06.01				OIL	200691	M 3805		516004
						OIL	201164	S 3804	600700	516010
, , ABS	(6U1, 6U5, 797)	10.94 - 06.01				OIL	200691	M 3805		516004
						OIL	201164	S 3804	600700	516010

FELICIA PICK-UP

	(6UF, 6U7)	06.97 - 04.02				OIL	200691	M 3805		516004
						OIL	201164	S 3804	600700	516010

FORMAN

SKODA (CS)

	(785)	08.91 - 10.94				OIL	200690	M 3803			516004
						OIL	201164	S 3804	600700		516010

OCTAVIA

1.4, 1.6, 1.9 SDI, 1.9 TDI excl. 4X4	(1U2)	10.96 - 12.10		4A		OIL	200772	M 4441	600270	516004
						GAS	210772	MG4441		
							GAS	211251	TG0317	
1.8, 2.0, 1.8 Turbo excl. RS 1.8 Turbo, 4X4	(1U2)	10.96 - 12.10		4B		OIL	200124	M 0316	600270	516004
						GAS	210124	MG0316		
							GAS	211251	TG0317	600290
4X2 excl. RS 1.8 Turbo	(1U5)	07.98 - 12.10		4A		OIL	200772	M 4441	600270	516004
						GAS	210772	MG4441	600270	
							GAS	211251	TG0317	600290
4X4	(1U5)	07.98 - 12.10		4A		OIL	200772	M 4441	600270	516004
						GAS	210772	MG4441	600270	
							GAS	211846	TG3809	
, excl.	(1Z3, 1Z5)	06.04 -		5A		GAS	210776	MG4455	600430	516004
				5B		GAS	210127	MG0343	600430	
						GAS	211916	TG4456		516010
	(1Z3)	06.04 -		5A		GAS	210777	MG4457	600430	516004
				5B		GAS	210128	MG0345	600430	
						GAS	211260	TG0344		516010
Assale rigido excl. RS	(5E3, 5E5)	11.12 -		5A		GAS	210785	MG4474		516004
				5B		GAS	210784	MG4471		
						GAS	211924	TG4472		516010
Assale Multilink excl. RS	(5E3, 5E5)	11.12 -		5A		GAS	210785	MG4474		516004
				5B		GAS	210784	MG4471		
						GAS	211925	TG4473		516010

RAPID

		02.83 - 10.91									516004

RAPID II

	(NH3)	07.12 -				GAS	210689	MG3719	600270	516004
						GAS	211843	TG3720	600290	516010
Spaceback	(NH1)	10.13 -				GAS	210689	MG3719	600270	516004
						GAS	211843	TG3720	600290	516010

ROOMSTER

incl. Praktik	(5J)	05.06 - 05.15				GAS	210688	MG3715	600350	516004
						GAS	211252	TG0320	600290	516010

SUPERB

excl.	(3U4)	02.02 - 03.08				GAS	211008	SG0339	600060	
						GAS	211253	TG0323		516010
	(3T4)	03.08 - 05.15				GAS	210776	MG4455	600430	516004
						GAS	211916	TG4456		516010
	(3T5)	10.09 - 05.15				GAS	210777	MG4457	600430	516004
						GAS	211260	TG0344		516010

SKODA (CS)

Assale multilink excl.	(3V3)	03.15 -		5A		GAS	210785	MG4474			516004
						GAS	211925	TG4473			516010
Assale multilink excl.	(3V5)	03.15 -		5A		GAS	210785	MG4474			516004
						GAS	211925	TG4473			516010

YETI

	(5L)	05.09 - 12.17		5B		GAS	210127	MG0343	600430	516004
				5A		GAS	210776	MG4455	600430	
						GAS	211848	TG3812		

SMART (D)

CABRIO

	(450)	03.00 - 01.04			$\frac{1}{2}$	GAS	212057	TG6001			
					$\frac{1}{2}$	GAS	212058	TG6002			
	(450)	03.00 - 01.04			$\frac{1}{2}$	GAS	211216	SG6003			
					$\frac{1}{2}$	GAS	212058	TG6002			

CITY-COUPÉ

	(MC01)	07.98 - 01.04			$\frac{1}{2}$	GAS	212057	TG6001			
					$\frac{1}{2}$	GAS	212058	TG6002			
	(MC01)	07.98 - 01.04			$\frac{1}{2}$	GAS	211216	SG6003			
					$\frac{1}{2}$	GAS	212058	TG6002			

CROSSBLADE

	(450)	06.02 - 12.03			$\frac{1}{2}$	GAS	212057	TG6001			
					$\frac{1}{2}$	GAS	212058	TG6002			
	(450)	06.02 - 12.03			$\frac{1}{2}$	GAS	211216	SG6003			
					$\frac{1}{2}$	GAS	212058	TG6002			

FORFOUR

	(454)	04.04 - 06.06			$\frac{1}{2}$	GAS	210937	MG6005	MG6006		
					$\frac{1}{2}$	GAS	212059	TG6007			
	(453)	07.2014 -			$\frac{1}{2}$	GAS	210671	MG3499			
					$\frac{1}{2}$	GAS	212094	TG6500			

FORTWO

	(450)	01.04 - 12.06			$\frac{1}{2}$	GAS	212057	TG6001			
					$\frac{1}{2}$	GAS	212058	TG6002			
	(450)	01.04 - 12.06			$\frac{1}{2}$	GAS	211216	SG6003			
					$\frac{1}{2}$	GAS	212058	TG6002			
	(451)	01.07 -			$\frac{1}{2}$	GAS	211217	SG6008			
					$\frac{1}{2}$	GAS	212060	TG6009			
	(453)	07.2014 -			$\frac{1}{2}$	GAS	210671	MG3499			
					$\frac{1}{2}$	GAS	212094	TG6500			

ROADSTER

	(452)	04.03 - 11.05			$\frac{1}{2}$	GAS	212057	TG6001			
					$\frac{1}{2}$	GAS	212058	TG6002			
	(452)	04.03 - 11.05			$\frac{1}{2}$	GAS	211216	SG6003			
					$\frac{1}{2}$	GAS	212058	TG6002			

SSANG YONG (KO)

KORANDO

	(KJ)	12.96 - 11.06			½	GAS	212045	TG5703			
					½	GAS	212046	TG5704			

MUSSO

	(FJ)	10.95 - 09.07			½	GAS	212043	TG5701			
					½	GAS	212044	TG5702			

REXTON

	(GAB)	04.02 - 08.06			¾	GAS	211214	SG5705			
					½	GAS	212047	TG5706			
	(GAB)	01.07 -			¾	GAS	211215	SG5707			
					½	GAS	212048	TG5708			

SUBARU (J)

FORESTER

2.0 4WD excl. Turbo,	(SF5)	08.97 - 09.02				GAS	210704	MG3923	MG3924			
						GAS	210705	MG3925	MG3926			
2.0, 2.0 Turbo 4WD, excl.	(SG5)	09.02 - 01.03				GAS	210711	MG3937	MG3936			
						GAS	210712	MG3939	MG3938			
2.0, 2.0 Turbo 4WD, excl. 2.5 excl.	(SG5) (SG5)	01.03 - 09.04				GAS	210713	MG3941	MG3940			
						GAS	210712	MG3939	MG3938			

IMPREZA

1.6, 1.8, 2.0 2WD	(GC, GF 3/5/7)	08.92 - 12.00				GAS	210706	MG3927	MG3928			
						GAS	210707	MG3929	MG3930			
1.6, 1.8, 2.0 4WD excl. 2.0 GT Turbo	(GC, GF 4/6/8)	08.92 - 12.00				GAS	210706	MG3927	MG3928			
						GAS	210709	MG3933	MG3934			
2.0 GT Turbo 4WD	(GC, GF 8_L8)	08.92 - 12.00				GAS	210708	MG3931	MG3932			
						GAS	210709	MG3933	MG3934			
2.0, 2.0 Turbo WRX excl. WRX-Sti	(GD)	10.00 - 10.02				GAS	210715	MG3945	MG3944			
						GAS	210716	MG3947	MG3946			
2.0, 2.0 Turbo WRX excl. WRX-Sti	(GD)	11.02 - 12.02				GAS	210715	MG3945	MG3944			
						GAS	210720	MG3955	MG3954			
2.0, 2.0 Turbo WRX excl. WRX-Sti	(GD)	01.03 - 06.09				GAS	210722	MG3959	MG3958			
						GAS	210716	MG3947	MG3946			
1.6, 2.0, 2.0 Turbo WRX	(GG)	10.00 - 10.02				GAS	210717	MG3949	MG3948			
						GAS	210718	MG3951	MG3950			
1.6, 2.0, 2.0 Turbo WRX excl. WRX-Sti	(GG)	11.02 - 12.02				GAS	210717	MG3949	MG3948			
						GAS	210719	MG3953	MG3952			
1.6, 2.0, 2.0 Turbo WRX excl. WRX-Sti	(GG)	01.03 - 12.08				GAS	210721	MG3957	MG3956			
						GAS	210719	MG3953	MG3952			

JUSTY

1.3	(HSJ56, HSN56)	10.95 - 08.03				GAS	210710	MG3935				
						GAS	210703	MG3922				
	(GX3)	09.03 -				GAS	210714	MG3943	MG3942			
						GAS	211696	TG2969				

LEGACY

4X2	(BC, BF, BJ)	01.89 - 12.91				GAS	210697	MG3911	MG3910			
						GAS	210701	MG3919	MG3918			
4X2	(BC, BF, BJ)	01.92 - 08.94				GAS	210698	MG3913	MG3912			
						GAS	210702	MG3921	MG3920			
4X4	(BC, BF, BJ)	01.89 - 12.91				GAS	210697	MG3911	MG3910			
						GAS	210699	MG3915	MG3914			
4X4 excl. 2.0 Turbo	(BC, BF, BJ)	01.92 - 08.94				GAS	210698	MG3913	MG3912			
						GAS	210700	MG3917	MG3916			
2.0 Turbo 4X4	(BC, BF 5_L8)	01.92 - 08.94				GAS	210723	MG3961	MG3960			
						GAS	210700	MG3917	MG3916			
4X2	(BD, BG)	01.94 - 1999				GAS	210706	MG3927	MG3928			
						GAS	210724	MG3963	MG3962			
2.0, 2.2 4X4	(BD, BG 5/7)	01.94 - 1999				GAS	210706	MG3927	MG3928			
						GAS	210725	MG3965	MG3964			

SUBARU (J)

2.5 4X4 excl. Outback	(BD, BG 9_L9)	06.96 - 1999				GAS	210723	MG3961	MG3960			
						GAS	210726	MG3967	MG3966			
2.5 Outback 4X4	(BG9_LB)	06.96 - 1999				GAS	210727	MG3969	MG3968			
						GAS	210728	MG3971	MG3970			
2.0, 2.5 4X4 excl. , , Outback	(BE, BH)	12.98 - 09.03				GAS	210729	MG3973	MG3972			
						GAS	211167	SG3974				
2.5 Outback 4X4 excl. ,	(BE, BH)	12.98 - 09.03				GAS	210730	MG3975	MG3976			
						GAS	211168	SG3977				
2.0i, 2.5i, 3.0R 4X4 excl. 3.0R Spec B, Outback	(BL)	09.03 - 11.15				GAS	210731	MG3979	MG3978			
						GAS	211169	SG3980				
2.0i, 2.5i, 3.0R Outback 4X4 excl.	(BP)	09.03 - 12.09				GAS	210732	MG3981	MG3982			
						GAS	211170	SG3983				

LEONE II / LOYALE / L

4X2	(AC)	09.84 - 09.91				GAS	210695	MG3903	MG3902			
						GAS	211165	SG3904				
4X2	(AG)	09.84 - 12.89				GAS	210695	MG3903	MG3902			
						GAS	211165	SG3904				
4X2	(AN)	09.84 - 12.93				GAS	210695	MG3903	MG3902			
						GAS	211166	SG3907				
, excl. excl. 1.8 Turbo, 4X4	(AC, AG, AN)	09.84 - 12.86 01.87 - 12.93				GAS	210696	MG3905	MG3906			
1.8 Turbo excl. excl. 4X4	(AC, AG, AN)	01.87 - 12.89 01.87 - 12.93				GAS	210696	MG3905	MG3906			
						GAS	211166	SG3907				

SUZUKI (J)

ALTO I / FRONTE

	(SS80)	1981 - 12.85					OIL	201314	H 0706				
--	--------	--------------	--	--	--	--	-----	--------	--------	--	--	--	--

ALTO II / FRONTE

(SB308)	(CA91, CB91)	12.85 - 12.87					OIL	200739	M 4020				516004
(SB308)	(CA91, CB91)	01.88 - 12.90					OIL	200739	M 4020				516004
(SB308)	(EC)	01.91 - 02.94					OIL	200739	M 4020				516004

ALTO III / FRONTE

(SH410)	(FA11, FB11)	10.94 - 06.02					GAS	210741	MG4029	MG4030			516004
							GAS	211860	TG4028				

ALTO IV / FRONTE

(RF410)	(FF)	06.02 - 12.08					GAS	211859	TG4027				
---------	------	---------------	--	--	--	--	-----	--------	--------	--	--	--	--

ALTO V

1.0	(HA25, HA35)	01.09 -					GAS	212120	MG4913	MG4912			516004
							GAS	211966	TG4899				

BALENO

1.3 (SY41_) excl.	(EG)	07.95 - 05.02					GAS	210742	MG4031	MG4032			516004
							GAS	210743	MG4033	MG4034			516004

CARRY

	(ST90V)	11.80 - 10.85					OIL	201314	H 0706				516004
excl. ,	(SK 408/410)	01.86 -					OIL	201314	H 0706				516004
,	(SK 408/410)	01.86 -					OIL	201315	H 0707				516004

GRAND VITARA

1.6 3(m)	(SQ416 - TA0)	03.98 - 09.05					GAS	210744	MG4037	MG4038			516004
							GAS	211863	HG4039				
2.0 3(m) 2.0 5(m)	(SQ420 - TA/L5)	03.98 - 09.05					GAS	210744	MG4037	MG4038			516004
							GAS	211863	HG4039				
2.0 TD 5(m) 2.5 5(m)	(SQ420 - TD3) (SQ420 - TD6)	03.98 - 09.05					GAS	210744	MG4037	MG4038			516004
							GAS	211863	HG4039				
1.6 3(m) 1.9 DDIS 3(m)	(XL6, XL7)	01.06 -					GAS	210745	MG4041	MG4040			516004
							GAS	211864	TG4042				
2.0 L 5(m) 1.9 DDIS 5(m)	(XL6, XL7)	01.06 -					GAS	210745	MG4041	MG4040			516004
							GAS	211864	TG4042				

SUZUKI (J)

IGNIS

🚗 1.3 2WD	(FH)	10.00 - 09.03				GAS	210746	MG4043	MG4044			516004
						GAS	211865	TG4045				
🚗 1.3 4WD	(FH)	10.00 - 09.03				GAS	210746	MG4043	MG4044			516004
						GAS	211866	TG4046				
🚗 1.3 2WD excl. 1.3 DDIS 🚗 1.5 2WD/4WD	(MH)	09.03 -				GAS	210714	MG3943	MG3942			516004
						GAS	211696	TG2969				
🚗 1.3 DDIS	(MH)	09.03 -				GAS	210747	MG4047	MG4048			516004
						GAS	211696	TG2969				

JIMNY

LJ 10, LJ 20 SJ 10, LJ 81		01.70 - 06.77				OIL	201850	H 4002				516004
		01.70 - 06.77				GAS	211835	TG3602				
LJ 80, LJ 80 Q, LJ 80 V LJ 81 K, LJ 81 P		06.77 - 12.81				OIL	201850	H 4002				516004
		06.77 - 12.81				GAS	211835	TG3602				
SJ 410, SJ 413		01.81 - 12.87				OIL	201850	H 4002				516004
						GAS	211835	TG3602				
						OIL	201367	H 1210				
SJ 413-4 Samurai ~		01.87 - 12.04				OIL	201850	H 4002				516004
						GAS	211835	TG3602				
						OIL	201367	H 1210				
SJ 419 Samurai		09.98 -										516004
🚗 (SN 413) 🇯🇵	(FJ)	09.98 -				GAS	211857	TG4023				516004
						GAS	211858	TG4024				

MARUTI

🚗		02.88 - 12.94				OIL	200738	M 4015	M 4014			
						OIL	201854	T 4016				

SPLASH

🚗		01.08 -				GAS	210748	MG4049	MG4050			516004
						GAS	211867	TG4051				516010

SWIFT I

🚗 1.0, 1.3 (SA 310, 413)	(AA41, AA51)	10.83 - 12.85										516004
🚗 1.0, 1.3, 1.3 GTi/GXi (SA 310-3, 413-3)	(AA43, AA53, AA33)	01.86 - 12.89										516004
												516010

SWIFT II

🚗 1.0 (SF310), excl. GTi, 4WD 🚗 1.3 (SF413), excl. GTi, 4WD	(AA/AB 44) (AA/AB 35)	03.89 - 1992				GAS	210734	MG4007				516004
		03.89 - 1992				GAS	210735	MG4008				516004
🚗 1.3 GTi (SF413) > Ch. S00104275	(AA 34)	03.89 - 12.89				GAS	210734	MG4007				516004
						GAS	210735	MG4008				516004
🚗 1.3 4WD (SF413) > Ch. S00102077	(AF 35)	03.89 - 12.90				GAS	210736	MG4009				516004
						GAS	210735	MG4008				516004

SUZUKI (J)

1.3 GTi (SF413) Ch. S00104276 > S0014000	(AA 34)	01.90 - 1992				GAS	210736	MG4009			516004
						GAS	210735	MG4008			516004
1.0 (SF310) 1.3 (SF413)	(AA/AB 44) (AA/AB 35)	1992 - 11.96				GAS	210736	MG4009			516004
						GAS	210735	MG4008			516004
1.3 GTi (SF413) Ch. S00140001 > 1.3 4WD (SF413) > Ch. S00102077	(AA 34) (AF 35)	1992 - 11.96 01.91 - 11.96				GAS	210736	MG4009			516004
						GAS	210735	MG4008			516004
1.3 (SF413) > Ch. 00107571	(AH 35)	03.89 - 1990				GAS	210736	MG4009			516004
						GAS	210735	MG4008			516004
1.6 2WD (SF416) > Ch. 00109591 1.6 4WD (SF416) > Ch. 00102383	(AH 14) (AJ 14)	03.89 - 1990				GAS	210736	MG4009			516004
						GAS	210735	MG4008			516004
1.3 (SF413) Ch. 00107572 >	(AH 35)	1990 - 11.96				GAS	210736	MG4009			516004
						GAS	210735	MG4008			516004
1.6 2WD (SF416) Ch. 00109592 > 1.6 4WD (SF416) Ch. 00102384 >	(AH 14) (AJ 14)	1990 - 11.96				GAS	210736	MG4009			516004
						GAS	210735	MG4008			516004
1.3 (SF413)	(AK 35)	09.91 - 11.96				GAS	210736	MG4009			516004
						GAS	210735	MG4008			516004

SWIFT III

1.3 1.5	(RS413) (RS415)	05.05 - 05.05 -				GAS	210748	MG4049	MG4050			516004
						GAS	211867	TG4051				

SWIFT IV

1.2, 1.3 DDiS excl. 4WD	(FZ, NZ)	10.10 -				GAS	210750	MG4055	MG4054			516004
						GAS	211867	TG4051	TG4051			

SX4

1.5L, 1.9 2WD excl. + 1.6L VVT 2WD excl. +		06.06				GAS	210158	MG0651	MG0652			516004
						GAS	211295	TG0653				
1.6L VVT 4WD 1.9L 4WD		06.06				GAS	210165	MG0665	MG0664			516004
						GAS	211299	TG0666				

VITARA / ESCUDO / SANTANA / SIDEKICK

2 (m) e-s		07.88 - 03.98				GAS	210737	MG4011	MG4010			516004
						GAS	211863	HG4039				
4 (m) e-s		01.91 - 03.98				GAS	210737	MG4011	MG4010			516004
						GAS	211863	HG4039				

WAGON R+

1.0 (SR410) 1.2 (SR412) incl. 4X4	(MA61) (MA81, MB81)	05.98 - 05.00 05.98 - 05.00				GAS	210740	MG4025	MG4026			516004
						GAS	211859	TG4027				
1.3 (RB413) excl. 4X4	(MA53)	06.00 -				GAS	210574	MG2995	MG2996	600620		516004
						GAS	211696	TG2969				

X-90

(SZ416)	(LAT, LB1)	09.95 - 12.97				GAS	210749	MG4053	MG4052			516004
						GAS	211863	HG4039				

TALBOT (F) (GB)

1100 / 1200 SIMCA

VF 1		1967 - 1980			½	OIL	201239	T 0119				
VF 2		1976 - 1980			½							
VF 2		1967 -			½	OIL	201239	T 0119				

1307 / 1308 / 1309

		1974 - 1980			½	OIL	201868	T 4101				
					½							

1510

1510, incl. Alpine		1979 - 1984			½	OIL	201870	T 4103				

ALPINE

Serie I, II, III		1959 - 1964			+							
		1970 - 1975			/							
		1976 - 1980			½	OIL	201868	T 4101				
					½							

EXPRESS

Express (> Fiat Ducato)		1983 -										
					∞	OIL	201347	H 0934				

HORIZON

1.1, 1.3, 1.5, 1.6, 1.9D		1977 - 1986			½	OIL	201870	T 4103				
					½							

MATRA - SIMCA BAGHEERA

	(XT)	1973 - 1980			½	OIL	201239	T 0119				

MINX

Serie I, II, III		1956 - 1963			+							
		01.67 - 10.70			/							
		01.67 - 10.70			/							
					∞							

SAMBA

excl. Rallye	(51A, 51E)	10.81 - 1986				OIL	200202	M 0914				
						OIL	201039	S 0913				
Rallye		10.81 - 1986										
						OIL	201039	S 0913				

TALBOT (F) (GB)

SOLARA / MINX / RAPIER

LS, GL, GLS, SX, Alpine	1979 - 1986			1/2	OIL	201870	T 4103			
				1/2						

SUMBEAM

excl. Lotus, Ti	1977 - 1982			/	OIL	200060	C 4105			
				1/2						

TAGORA

	1980 - 1985			/						
				1/2	OIL	201715	H 3033			

TOYOTA (J)

4 RUNNER

RN 61		12.87 - 03.89			⊖	GAS	211884	HG4243			
					⊕	GAS	211248	HG0201			
LN 130, VZN 130 4X4		08.89 - 11.95			⊖	GAS	211884	HG4243			
					⊖	GAS	211885	HG4244			
RZN 180, RZN 185, VZN 185		11.95 -									
					⊖						

AURIS

	(_E15_)	10.06 - 09.12				GAS	210866	MG5099	MG5098			516004
					⊖	GAS	211996	TG5100				516010
	(_E18_)	10.12 -				GAS	210866	MG5099	MG5098			516004
					⊖	GAS	211996	TG5100				516010
 excl. versioni D-4D,	(_E18_)	07.13 -				GAS	210866	MG5099	MG5098			516004
					⊖	GAS	212114	TG5109				516010

AVENSIS

	(A/S/CT220/1)	09.97 - 07.00				GAS	210764	MG4295	MG4296			516004
						GAS	210765	MG4297	MG4298			516004
	(_ZT220/1) (CDT220)	07.00 - 12.02				GAS	210764	MG4295	MG4296			516004
						GAS	210765	MG4297	MG4298			516004
	(_T250/251)	04.03 - 11.08				GAS	210845	MG5027	MG5026			516004
						GAS	211199	SG5028				516010

AVENSIS VERSO

2.0, 2.0 D	(ACM20, CLM20)	08.01 - 11.09				GAS	210846	MG5029	MG5030			516004
					⊖	GAS	211977	TG5031				516010

AYGO

1.0i, 1.4D	(B1)	07.05 -				GAS	210223	MG0981	MG0982			516004
					⊖	GAS	211356	TG0983				516010

AYGO II

	(B4)	05.14 -				GAS	210223	MG0981	MG0982			516004
					⊖	GAS	211356	TG0983				516010

CAMRY

1.8 2.0	(SV10)	10.82 - 09.86			/							516004
	(SV11, CV11)	06.83 - 09.86				GAS	210755	MG4220				516004
1.8 D Turbo	(CV10)	05.85 - 09.86			/							516004
						GAS	210755	MG4220				516004
1.8, 2.0 excl. 4X4	(SV20/21)	10.86 - 08.91 01.89 - 08.91			/	GAS	210063	CG4203				516004
					/							516004
2.5 V6 excl. 4X4 2.0 D Turbo excl. 4X4	(ZV21)	10.86 - 08.91			/	GAS	210063	CG4203				516004
	(CV20)	01.89 - 08.91			/							516004
2.0 4X4	(SV25)	08.88 - 08.91			/							516004
												516004
2.2 3.0 V6	(SVX10)	10.91 - 08.96				GAS	210848	MG5035	MG5036			516004
	(VCV10)	10.91 - 08.96				GAS	210760	MG4277	MG4278			516004

TOYOTA (J)

2.2	(SVX20)	09.96 - 2001				GAS	210842	MG5021	MG5020			516004
3.0 V6	(MCV20)	09.96 - 2001				GAS	210843	MG5023	MG5022			516004
2.0, 2.4, 3.0	(ACV30/31, MCV30)	08.01 -				GAS	210849	MG5037	MG5038			516004
2.0, 2.4, 3.0	(ACV30/31, MCV30)	08.01 -				GAS	210850	MG5039	MG5040			516004
Wagon 1.8, 2.0	(SV20/21)	10.86 - 02.92				GAS	210063	CG4203				516004
Wagon 2.0 D Turbo	(CV20)	10.86 - 02.92										516004
Wagon 2.2	(SVX10)	03.92 - 12.94				GAS	210759	MG4275	MG4276			516004
Wagon 3.0 V6	(VCV10)	03.92 - 12.94				GAS	210760	MG4277	MG4278			516004
Wagon 2.2	(SVX10)	01.95 - 08.96				GAS	210848	MG5035	MG5036			516004
Wagon 3.0 V6	(VCV10)	01.95 - 08.96				GAS	210760	MG4277	MG4278			516004

CARINA II / CORONA

1.6	(AT151)	10.83 - 12.87				GAS	210068	CG4209				516004
1.6	(AT151)	10.83 - 12.87										516004
1.8, 2.0 D	(ST150, CT150)	10.83 - 12.87				GAS	210070	CG4211				516004
2.0	(ST151)	08.85 - 12.87										516004
1.5	(AT171)	12.87 - 12.89				GAS	210068	CG4209				516004
1.6	(AT171)	12.87 - 12.89				GAS	210752	MG4212				516004
1.5	(AT171)	12.89 - 03.92				GAS	210068	CG4209				516004
1.6	(AT171)	12.89 - 03.92				GAS	210752	MG4212				516004
1.8, 2.0	(ST171)	12.87 - 12.89				GAS	210063	CG4203				516004
1.8 D, 2.0 D	(CT170)	12.87 - 12.89				GAS	210752	MG4212				516004
1.8, 2.0	(ST171)	12.89 - 03.92				GAS	210063	CG4203				516004
1.8 D, 2.0 D	(CT170)	12.89 - 06.93				GAS	210752	MG4212				516004
Wagon 1.5	(AT171)	12.87 - 12.89				GAS	210068	CG4209				516004
Wagon 1.6	(AT171)	12.87 - 12.89				GAS	210752	MG4212				516004
Wagon 1.5	(AT171)	01.90 - 10.92				GAS	210068	CG4209				516004
Wagon 1.6	(AT171)	01.90 - 10.92				GAS	210752	MG4212				516004
Wagon 1.8, 2.0	(ST171)	12.87 - 12.89				GAS	210063	CG4203				516004
Wagon 1.8 D, 2.0 D	(CT170)	12.87 - 12.89				GAS	210752	MG4212				516004
Wagon 1.8, 2.0	(ST171)	01.90 - 10.92				GAS	210063	CG4203				516004
Wagon 1.8 D, 2.0 D	(CT170)	01.90 - 10.92				GAS	210752	MG4212				516004

CARINA E / CORONA

1.6	(AT190)	02.92 - 01.96				GAS	210837	MG5003	MG5004			516004
1.6	(AT190)	02.92 - 01.96				GAS	210838	MG5005	MG5006			516004
2.0 excl. Gfi	(ST191)	02.92 - 01.96				GAS	210837	MG5003	MG5004			516004
2.0	(ST191)	02.92 - 01.96				GAS	210838	MG5005	MG5006			516004
2.0 Gfi	(ST191)	02.92 - 01.96										516004
2.0	(ST191)	02.92 - 01.96				GAS	210838	MG5005	MG5006			516004
2.0 D, 2.0 TD	(CT190)	02.92 - 01.96				GAS	210837	MG5003	MG5004			516004
2.0 D, 2.0 TD	(CT190)	02.92 - 01.96				GAS	210838	MG5005	MG5006			516004
Wagon 1.6	(AT190)	11.92 - 05.93				GAS	210837	MG5003	MG5004			516004
Wagon 1.6	(AT190)	11.92 - 05.93				GAS	210765	MG4297	MG4298			516004
Wagon 1.6	(AT190)	06.93 - 02.94				GAS	210837	MG5003	MG5004			516004
Wagon 1.6	(AT190)	06.93 - 02.94				GAS	210765	MG4297	MG4298			516004
Wagon 1.6	(AT190)	03.94 - 01.96				GAS	210837	MG5003	MG5004			516004
Wagon 1.6	(AT190)	03.94 - 01.96				GAS	210838	MG5005	MG5006			516004
Wagon 2.0	(ST191)	11.92 - 05.93				GAS	210837	MG5003	MG5004			516004
Wagon 2.0 D	(CT190)	11.92 - 05.93				GAS	210765	MG4297	MG4298			516004

TOYOTA (J)

Wagon 2.0	(ST191)	06.93 - 09.97			GAS	210837	MG5003	MG5004			516004
Wagon 2.0 D	(CT190)	06.93 - 02.94			GAS	210765	MG4297	MG4298			516004
Wagon 2.0 D	(CT190)	03.94 - 01.96			GAS	210837	MG5003	MG5004			516004
					GAS	210838	MG5005	MG5006			516004

CELICA

	(AT160, ST160, ST162)	08.85 - 08.87			GAS	210070	CG4211				516004
					GAS	210753	MG4217				516004
	(AT160, ST162)	08.87 - 08.89			GAS	210063	CG4203				516004
					GAS	210752	MG4212				516004
	(AT180, ST182)	09.89 - 10.93			GAS	210072	CG4218				516004
					GAS	210754	MG4219				516004
	(ST185)	09.89 - 10.93			GAS	210072	CG4218				516004
					GAS	210761	MG4281	MG4282			516004
	(AT200, ST202)	11.93 - 11.99			GAS	210074	CG4279				516004
		11.93 - 11.99			GAS	210841	MG5019	MG5018			516004
	(ST205)	11.93 - 11.99			GAS	210851	MG5041	MG5042			516004
					GAS	210852	MG5043	MG5044			516004
	(ZZT230)	08.99 - 11.99			GAS	210853	MG5045	MG5046			516004
					GAS	211978	TG5047				
	(ZZT230)	10.99 - 08.00			GAS	210853	MG5045	MG5046			516004
					GAS	211200	SG5048				
	(ZZT23#)	08.00 - 09.05			GAS	210853	MG5045	MG5046			516004
					GAS	211200	SG5048				

COASTER

RU 19, BU 19		02.72 - 07.77			GAS	211367	HG1210				
					OIL	201377	T 1303				
RB 10, 11, 12, 13, BB 10		08.77 - 04.82			OIL	201377	T 1303				
					OIL	201377	T 1303				

COROLLA

	(AE80, EE80, AE82)	05.83 - 05.87			GAS	210068	CG4209				
					GAS	210755	MG4220				516004
	(CE80)	05.83 - 05.87			GAS	210070	CG4211				
					GAS	210755	MG4220				
	(AE82)	10.84 - 05.87			GAS	210070	CG4211				
											516004
	(EE90)	06.87 - 12.92			GAS	210068	CG4209				
					GAS	210844	MG5025	MG5024			516004
	(AE92)	06.87 - 12.92			GAS	210063	CG4203				
					GAS	210844	MG5025	MG5024			516004
	(CE90, CE92)	06.87 - 06.93			GAS	210063	CG4203				
					GAS	210844	MG5025	MG5024			516004
	(A/EE100/1, CE100)	05.92 - 04.97			GAS	210756	MG4223	MG4222			516004
					GAS	210757	MG4225	MG4224			516004
	(A/EE110/1, AE115, CE11_)	04.97 - 01.02			GAS	210756	MG4223	MG4222			516004
					GAS	210757	MG4225	MG4224			516004
	(ZZE11_)	10.99 - 09.01			GAS	210756	MG4223	MG4222			516004
					GAS	210757	MG4225	MG4224			516004

TOYOTA (J)

1.4, 1.6 excl. Auto. 2.0 TD	(ZZE120/1) (CDE120)	10.01 -				GAS	210854	MG5053	MG5054			516004
						GAS	211201	SG5055				516010
1.6 Auto.	(ZZE121)	10.01 -				GAS	210854	MG5053	MG5054			516004
						GAS	211206	SG5094				516010
Station Wagon 1.3, 1.6	(EE90, AE92)	06.87 - 06.92				GAS	210068	CG4209				
						GAS	210844	MG5025	MG5024			516004
Station Wagon 1.6 4X4	(AE95)	10.87 - 12.92										
						GAS	211626	TG2801				516010
Station Wagon 1.8 D	(CE90, CE92)	06.87 - 06.92				GAS	210063	CG4203				
						GAS	210844	MG5025	MG5024			516004
Wagon 1.3, 2.0 D Wagon 1.6	(C/EE100/1) (AE101)	05.92 - 04.97				GAS	210756	MG4223	MG4222			516004
						GAS	210757	MG4225	MG4224			516004
Wagon 1.3, 1.4, 1.6 Wagon 1.8, 2.0 D	(A/EE110/1) (AE115, CE11_)	04.97 - 09.01				GAS	210756	MG4223	MG4222			516004
						GAS	210757	MG4225	MG4224			516004
1.4, 1.6 2.0 TD	(ZZE120/1) (CDE120)	10.01 - 05.04				GAS	210854	MG5053	MG5054			516004
						GAS	211201	SG5055				516010
excl.	(_E18_)	06.13 -				GAS	210866	MG5099	MG5098			516004
						GAS	211996	TG5100				

COROLLA VERSO

1.6, 1.8 2.0 TD	(ZZE121/2) (CDE120)	09.01 - 12.03				GAS	210854	MG5053	MG5054			516004
						GAS	211201	SG5055				
1.6, 1.8 2.0 TD	(ZNR10/1) (CUR10)	02.04 - 03.09				GAS	210855	MG5057	MG5058			516004
						GAS	211202	SG5056				

CROWN

1.9 2.0, 2.3	(RS41) (MS41/5)	01.65 - 08.67				±	GAS	211601	TG2622				
2.0	(MS46)	01.65 - 07.67				±	GAS	211601	TG2622				
						∞							
2.0 2.3	(RS50, RS60) (MS51, MS55)	09.67 - 09.74 09.67 - 01.71				±	GAS	211601	TG2622				
2.0, 2.3 2.6	(RS80, MS64) (MS65/75)	10.74 - 08.79 02.71 - 08.79				±	GAS	211601	TG2622				
2.0, 2.2 D 2.6, 2.8	(RS110, LS110) (MS111, MS112)	09.79 - 07.83				±	GAS	211601	TG2622				
						∞	GAS	211684	TG2936				
2.0, 2.5 D 2.8	(Y/LS120) (MS122)	08.83 - 09.87				±	GAS	211601	TG2622				
2.8	(MS123, MS125)	08.83 - 09.87				±							
2.0 2.3	(MS56, RS56) (MS57, RS57)	08.67 - 01.71				±	GAS	211601	TG2622				
						∞							
2.3 2.6	(MS67) (MS63/68)	02.71 - 01.73 02.71 - 08.79				±	GAS	211601	TG2622				
						∞							
2.2 D, 2.6 2.8	(L/MS111) (MS112, MS122)	09.79 - 07.80 09.79 - 09.87				±	GAS	211601	TG2622				
						∞	GAS	211684	TG2936				

DYNA

RU/JU/BU 10, 12, 15 RU/JU/BU 10, 12, 15 H		01.69 - 07.77				∞	GAS	211367	HG1210				
						∞	OIL	201377	T 1303				

TOYOTA (J)

HU 15 H		01.72 - 07.77			⊕	OIL	201377	T 1303			
					⊕	OIL	201377	T 1303			
BU 20, 30, 35, 36 JU 20 RU/HU 20, 30		07.77 - 11.84			⊖	GAS	211626	TG2801			
					⊕	OIL	201377	T 1303			
BU 75 BU 85		08.87 - 05.95			⊖						
					⊕						

DYNA 100

LH 80 YH 81		08.85 - 05.95			⊖	OIL	201645	H 2862			
					⊕						
LY 100		05.95 -			⊖	OIL	201645	H 2862			
					⊕						

HI-ACE

PH 10, LH 10, RH 10 series		10.67 - 01.77			⊖						
					⊕	OIL	201377	T 1303			
RH 20, RH 30, RH 40 series excl. RH22, RH24 LH 20, LH 30, LH 40 series		02.77 - 11.82			⊖						
					⊕	OIL	201377	T 1303			
RH 22		02.77 - 11.82			⊖						
					⊕						
LH 50, LH 60, LH 70 series YH 50, YH 60, YH 70 series, YH (Serie 50,60,70)		11.82 - 12.83			⊖	GAS	211635	HG2837			
					⊕	GAS	211367	HG1210			
LH 50, LH 60, LH 70 series 4X2 YH 50, YH 60, YH 70 series 4X2		01.84 - 08.89			⊖	GAS	211635	HG2837			
					⊕						
LH 56, LH 66, YH 56, YH 66 series 4X4		08.86 - 08.89			⊖	GAS	211875	HG4232			
					⊕						
LH 102, LH 112 4X2 RZH 102/103/112/113/115		08.89 - 08.95			⊖	GAS	211489	HG1901			
					⊕	GAS	211876	HG4234			
LH 108, LH 118, RZH 109, RZH 119 4X4		08.89 - 08.95			⊖	GAS	211875	HG4232			
					⊕	GAS	211877	HG4235			
LXH 12, LXH 22 4X2 RCH 12, RCH 13, RCH 22, RCH 23 4X2		08.95 - 10.99			⊖	GAS	211489	HG1901			
					♀	GAS	211983	HG5059			
LXH 18, LXH 28 4X4 RCH 18, RCH 19, RCH 28, RCH 29 4X4		08.95 - 07.99			⊖	GAS	211875	HG4232			
					♀	GAS	211984	HG5060			
RCH 12, RCH 13, RCH 22, RCH 23 4X2		07.99 -			⊖	GAS	211489	HG1901			
					♀	GAS	211984	HG5060			
KLH 12, KLH 22 4X2 LXH 12, LXH 22 4X2		07.99 -			⊖	GAS	211489	HG1901			
					♀	GAS	211984	HG5060			
KLH 18, KLH 28 4X4 LXH 19, LXH 29 4X4		07.99 -			⊖	GAS	211875	HG4232			
					♀	GAS	211984	HG5060			
RCH 19, RCH 22 4X4		07.99 -			⊖	GAS	211875	HG4232			
					♀	GAS	211984	HG5060			

HI-LUX

RN 10/13/15/16/20 4X2 RN 22/25/27/28 4X2		01.68 - 01.79			⊖						
					⊕	OIL	201377	T 1303			
RN 30/31/32/33/34/35 4X2 RN 40/41/42/44 4X2		01.78 - 03.84			⊖						
					⊕	OIL	201377	T 1303			
LN 30/40 4X2		01.78 - 03.84			⊖						
					⊕	OIL	201377	T 1303			

TOYOTA (J)

RN 36/39/46 4X4 LN 36/46 4X4		01.79 - 07.83			♂	GAS	211878	HG4236			
					♀	GAS	211596	HG2616			
LN 50/51/55/56 4X2		08.83 - 08.88			±	GAS	211879	HG4237			
				N.D.	♀	OIL	201377	T 1303			
YN 50/51/52/55/56 4X2 YN 57/58/, RN 50/55 4X2		08.83 - 08.88			±	GAS	211879	HG4237			
				N.D.	♀	OIL	201377	T 1303			
LN 60/61/65 4X4 ~ YN 60/61/62/65/67 4X4 ~		08.83 - 08.88			♂	GAS	211878	HG4236			
					♀	GAS	211881	HG4239			
LN 85/90 4X2 YN 85/90 4X2		08.88 - 08.97			±	GAS	211879	HG4237			
					♀	GAS	211625	HG2702			
LN 105 4X4 YN 106 4X4		08.88 - 08.97			♂	GAS	211882	HG4241			
					♀	GAS	211883	HG4242			
LN 108, LN110 4X4 RN 106, RN110, YN 110 4X4		08.88 - 08.97			♂	GAS	211884	HG4243			
					♀	GAS	211883	HG4242			
LN 145, LN150 4X2		08.97 - 08.01			±	GAS	211879	HG4237			
					♀	GAS	211997	HG5102			
LN 165, LN170 4X4 RZN168, RZN173 4X4		08.97 - 08.01			♂	GAS	211884	HG4243			
					♀	GAS	211985	HG5061 HG5062			
KDN145, KDN150		08.01 -			±	GAS	211879	HG4237			
					♀	GAS	211997	HG5102			
KDN165, KDN170, KDN190		08.01 -			♂	GAS	211884	HG4243			
					♀	GAS	211985	HG5061 HG5062			

IQ

EXCL. EV	(KPJ1_) (GJ11_, UJ1_)	01.09 -			♂	GAS	210867	MG5103 MG5104			516004
					♀	GAS	211998	TG5105			516010

LAND CRUISER

FJ 40, FJ 43, FJ 45 BJ 40, BJ 43		03.69 - 04.86			♀	GAS	211367	HG1210			
		02.74 - 10.84			♀	GAS	211596	HG2616			
FJ 55, BJ 55		03.69 - 03.71			♂						
					♀	OIL	201377	T 1303			
FJ 42 HJ 45		03.69 - 03.72			♀	GAS	211367	HG1210			
		04.72 - 07.80			♀	GAS	211596	HG2616			
FJ 55, BJ 55, FJ 56V		04.71 - 07.80			♂						
					♀	GAS	211596	HG2616			
BJ 42, BJ 45, BJ 46 HJ 47		08.80 - 10.84			♀	GAS	211367	HG1210			
		08.80 - 06.85			♀	GAS	211596	HG2616			
BJ 70, BJ 71, BJ 73 ~		1984 - 12.89			♂	GAS	211886	HG4245			
					♀	GAS	211881	HG4239			
BJ 75, HJ 75 ~		1984 - 12.89			♂	GAS	211886	HG4245			
					♀						
LJ 70, LJ 73 <small>1984</small> RJ 70, RJ 73 <small>1984</small>		1984 - 12.89			+	GAS	211887	HG4247			
		1984 - 12.89			♂	GAS	211888	HG4249			
					♀	GAS	211888	HG0201			
BJ 60, FJ 60, FJ 62, HJ 60, HJ 61 Station Wagon (Model #J6##G)	(WGG)	08.80 - 10.85			♂	GAS	211889	HG4250			
					♀	GAS	211596	HG2616			
BJ 60, FJ 60, FJ 62, HJ 60, HJ 61 ↶ (Model#J6##V)	(WGV)	08.80 - 10.85			♂	GAS	211886	HG4245			
					♀	GAS	211596	HG2616			

TOYOTA (J)

BJ 60, FJ 60, FJ 62, HJ 60, HJ 61 Station Wagon (Model#J6##G-)	(WGG)	10.85 - 08.87			♂	GAS	211889	HG4250			
					♀	GAS	211248	HG0201			
BJ 60, FJ 60, FJ 62, HJ 60, HJ 61 ↳ (Model#J6##V-)	(WGV)	10.85 - 08.87			♂	GAS	211886	HG4245			
					♀	GAS	211248	HG0201			
HJ 60, HJ 61		08.87 - 12.89			♂	GAS	211889	HG4250			
					♀	GAS	211248	HG0201			
HZJ 70, HZJ 73 ~ PZJ 70, PZJ 73 ~		01.90 - 08.99			♂	GAS	211886	HG4245			
					♀	GAS	211890	HG4252			
LJ 70/73/77/79, RJ 70/3 ■ LJ70, LJ73, RJ70, KZJ 70 ■		01.90 - 04.93 05.93 - 12.94			♀	GAS	211891	HG4253			
					♀	GAS	211892	HG4254			
HZJ 75, PZJ 75		01.90 - 08.99			♂	GAS	211886	HG4245			
					♀	GAS	211991	HG5068			
HZJ 71, HZJ 74		08.99 - 08.01			+	GAS	211987	HG5063			
					♀	GAS	211890	HG4252			
HZJ 78		08.99 - 08.01			+	GAS	211987	HG5063			
					♀	GAS	211988	HG5064			
HZJ 79		08.99 - 08.01			+	GAS	211987	HG5063			
					♀	GAS	211989	HG5065			
FJ 80, HDJ 80, HZJ 80 ■		01.90 - 12.98			+	GAS	211893	HG4255			
					♂	GAS	211894	HG4256			
KZJ7#, RJ7#, LJ70, LJ72		05.93 -			♀	GAS	211891	HG4253			
					♀	GAS	211892	HG4254			
KZJ 90/95, VZJ 90/95		04.96 - 09.02			↗	GAS	211197	SG5009			
					♂	GAS	211973	HG5011			
HDJ 100/105, UZJ 100/105 excl. □		01.98 -			♂	GAS	211972	HG5010			
					♂	GAS	211974	HG5012			
KDJ 120, KDJ 125 excl. †		09.02 - 03.10			↗	GAS	211203	SG5066			
					♂	GAS	211990	TG5067			

LITE-ACE

	(CR21, KR21, YR22)	01.92 - 01.95			±	GAS	211602	HG2623			
					♂						
	(CR27, KR27, YR29)	01.92 - 01.95			±	GAS	211602	HG2623			
					♀						
	(KM67)	01.92 - 01.95			±	GAS	211602	HG2623			
					♀						

MR-2

1.6	(AW10, AW11)	11.84 - 06.90			/	GAS	210073	CG4263			516004
					/						516004
2.0 16V	(SW20)	1990 - 2000			/	GAS	210089	CG5069			516004
					/	GAS	210090	CG5070			516004
1.8	(W3)	2000 - 06.07			↗	GAS	210856	MG5071	MG5072		516004
					↗	GAS	210857	MG5073	MG5074		516004

PASEO

	(EL54)	08.95 - 07.99			↗	GAS	210762	MG4287	MG4288		516004
					↗	GAS	211172	SG4291			

TOYOTA (J)

PICNIC

	(SXM10, CXM10)	09.96 - 05.01				GAS	210836	MG5001	MG5002			516004
						GAS	211971	TG5008				516010

PREVIA

TCR 10, TCR 20 4X2, 4X4 T-H		06.90 - 08.00				GAS	210758	MG4265	MG4264			516004
						GAS	211897	HG4274				
TCR 11, TCR 21 4X2, 4X4 T-H		06.90 - 08.00				GAS	210758	MG4265	MG4264			516004
						GAS	211896	HG4266				
	(R30)	04.00 - 01.06				GAS	210858	MG5075	MG5076			516004
						GAS	211992	HG5077				

PRIUS

	(HW1)	08.00 - 07.03				GAS	210859	MG5079	MG5078			516004
						GAS	211204	SG5080				
	(HW2)	08.03 - 03.09				GAS	210860	MG5081	MG5082			516004
						GAS	211205	SG5083				
	1.8 Hybrid (ZVW3)	04.09 -				GAS	210868	MG5107	MG5106			516004
						GAS	211999	TG5108				

RAV-4 / FUN CRUISER

	excl. 235/60 R 16"	(SXA10, SXA11)	04.94 - 06.00				GAS	210075	CG4284				516004
							GAS	210861	MG5085	MG5084			
							GAS	211993	HG5088				
ACA 20, ZCA 25 3m	(XA2)	06.00 - 11.05				GAS	210862	MG5087	MG5086			516004	
						GAS	211993	HG5088					
ACA 21, ZCA 26 5m	(XA2)	06.00 - 11.05				GAS	210863	MG5089	MG5090			516004	
						GAS	211993	HG5088					
	(ACA, ACE, ALA)	03.06 -				GAS	210865	MG5095	MG5096	600420		516004	
						GAS	211995	TG5097					
	(A4)	12.12 -				GAS						516004	
						GAS	211995	TG5097					

STARLET

	1.0, 1.3, 1.3 Turbo	(EP80/1/2)	12.89 - 05.94				GAS	210763	MG4293	MG4294			516004
							GAS	211171	SG4285				
	1.5 D	(NP80)	12.89 - 05.94				GAS	210763	MG4293	MG4294			516004
							GAS	211198	SG5013				
	1.0, 1.3, 1.3 Turbo	(EP80/1/2)	06.94 - 03.96				GAS	210763	MG4293	MG4294			516004
							GAS	211198	SG5013				
	1.5 D	(NP80)	06.94 - 03.96				GAS	210763	MG4293	MG4294			516004
							GAS	211172	SG4291				

SUPRA / SOARER

3.0 24V	(MA70)	01.86 - 05.93				GAS	211979	TG5049				516004
						GAS	211980	TG5050				
3.0 24V	(JZA80)	05.93 - 01.96				GAS	211981	TG5051				516004
						GAS	211982	TG5052				

TOYOTA (J)

YARIS

1.0, 1.3 1.4 TD	(S/NCP10) (NLP10)	04.99 - 09.05				GAS	210839	MG5014	600670	516004
						GAS	211975	TG5016		516010
1.5 TS	(NCP13)	01.01 - 09.05				GAS	210839	MG5014	600670	516004
						GAS	211975	TG5016		516010
	(SCP9, NSP9, KSP9, NCP9, ZSP9)	01.06 -				GAS	210864	MG5091 MG5092		516004
						GAS	211994	TG5093		516010
	(NLP13, NSP13, NCP13, KSP13)	09.11 -				GAS	210864	MG5091 MG5092		516004
						GAS	211994	TG5093		516010

YARIS VERSO

	(NCP20/1/2) (NLP20/22)	08.99 - 09.05				GAS	210840	MG5015	600670	516004
						GAS	211976	TG5017		516010

VAUXHALL (GB)

AGILA

	(H00)	09.00 -		/	GAS	210574	MG2995	MG2996	600620	516004
				♀	GAS	211696				

ASTRA MK I / BELMONT

		09.79 - 08.86		/	OIL	200046	C 2927			
				/	GAS	210046	CG2927			
		09.79 - 08.86		♂	OIL	201662	T 2905			
				/	OIL	200046	C 2927			
		09.79 - 08.86		/	GAS	210046	CG2927			
				♀	OIL	201678	T 2928			

ASTRA MK II / BELMONT

excl. GSI, GTE > Ch. J2791967 > Ch. J5273427		09.84 - 07.88		/	OIL	200046	C 2927			516004
				/	GAS	210046	CG2927			
excl. GSI, GTE Ch. J2791968 > Ch. J5273428 >		08.88 - 08.91		♂	GAS	211662	TG2905			516010
				/	OIL	200046	C 2927			
excl. GSI, GTE Ch. J2791968 > Ch. J5273428 >		08.88 - 08.91		/	GAS	210046	CG2927			516004
				♂	OIL	201663	T 2908			516010
GSI, GTE > Ch. J2791967, > Ch. J5273427		09.84 - 07.88		♂	GAS	211662	TG2905			516010
				/	GAS	210046	CG2927			516004
GSI, GTE Ch. J2791968 >, Ch. J5273428 >		08.88 - 08.91		♂	GAS	211663	TG2908			516010
				/	GAS	210046	CG2927			516004
		09.84 - 08.91		/	OIL	200046	C 2927			516004
				/	GAS	210046	CG2927			
		09.84 - 08.91		♀	OIL	201664	T 2909			
				♀	GAS	211664	TG2909			

ASTRA MK III

excl. GT, GSI		09.91 - 09.98		/	OIL	200043	C 2907	600020	516004
				/	GAS	210043	CG2907		
GT		09.91 - 09.98		♂	OIL	201663	T 2908		516010
				♂	GAS	211663	TG2908		
GSI		09.91 - 09.98		/	GAS	210043	CG2907	600020	516004
				♂	GAS	211685	TG2939		516010
		09.91 - 09.98		/	OIL	200043	C 2907	600020	516004
				/	GAS	210043	CG2907		
excl. 2.0 GSI		09.91 - 09.98		♀	OIL	201664	T 2909		
				excl. ♀	♀	GAS	211664	TG2909	
2.0 GSI		09.91 - 09.98		/	GAS	210043	CG2907	600020	516004
				♂	GAS	211663	TG2908		516010
		09.91 - 09.98		/	GAS	210043	CG2907	600020	516004
				♂	GAS	211663	TG2908		516010

VAUXHALL (GB)

ASTRA MK IV

excl.		04.98 - 04.04				GAS	210562	MG2953	MG2954	600380	516004
						GAS	211689	TG2955			
,		04.98 - 04.04				GAS	210562	MG2953	MG2954	600380	
						GAS	211690	TG2956			

ASTRA MK V

,		01.04 - 05.09				GAS	210569	MG2983	MG2982	600160	516004
						GAS	211703	TG2986			
		08.04 -				GAS	210569	MG2983	MG2982	600160	516004
						GAS	211702	TG2981			

BRAVA

TFR Series 4X2		08.91 -									
TFS Series 4X4		08.91 -				GAS	211670	HG2916			516004
						GAS	211490	HG1902			

CALIBRA

2.0, 2.0 16V, 2.5 V6 excl. 2.0 Turbo excl.		06.90 - 08.98				/	GAS	210044	CG2912	600030	516004
						excl.		GAS	211667	TG2913	

CARLTON

		10.78 - 08.86				/	GAS	210045	CG2923		
							OIL	201675	T 2922		
		10.78 - 08.86				/	GAS	210045	CG2923		
							GAS	211684	TG2936		
1.8, 2.0, 2.4, excl. 2.3 D, 2.3 TD, excl.		09.86 - 04.94 09.86 - 04.94					GAS	210555	MG2932		516004
							GAS	211682	TG2933		516010
2.6, 3.0, 3.0 24V excl. Lotus,		09.86 - 04.94					GAS	210556	MG2934		516004
							GAS	211682	TG2933		516010
 excl.		09.86 - 04.94					GAS	210555	MG2932		516004
							GAS	211683	TG2935		516010

CAVALIER

		1975 - 08.81					OIL	201661	T 2903			
							GAS	211660	TG2902			
> Ch. F1003026 > Ch. F5000000 > Ch. F6000000		09.81 - 12.85				/	GAS	210041	CG2904			
							OIL	201662	T 2905			
							GAS	211662	TG2905			
Ch. F1003027 > Ch. F5000001 > Ch. F6000001 >		01.85 - 08.88				/	GAS	210042	CG2906		516004	
							OIL	201662	T 2905		516010	
							GAS	211662	TG2905			
, 1.4, 1.4, 1.6, 1.6, 1.7 D , 1.8, 1.8, 2.0, 1.7 TD excl. 4X4		09.88 - 11.95				/	GAS	210044	CG2912	600030		
						excl.		OIL	201662	T 2905		
						excl.		GAS	211662	TG2905		
, 2.0 16V excl. 4X4 > Ch. NV199999, N1999999, N5999999		09.88 - 12.92				/	GAS	210044	CG2912	600030		
						excl.		GAS	211682	TG2933		

VAUXHALL (GB)

 2.0 16V excl. 4X4 Ch. NV199999, N1999999, N5999999 >	01.93 - 11.95			/	GAS	210044	CG2912	60030	
			excl. ♡	♂	OIL	201663	T 2908		
 1.8, 2.0, 2.0 16V excl. Turbo 4X4	09.88 - 11.95			/	GAS	210044	CG2912	60030	
			excl. ♡	♂	GAS	211682	TG2933		
> Ch. F1003026, F5000000, F6000000	09.81 - 12.85			/	GAS	210041	CG2904		516004
Ch. F1003027, F5000001, F6000001 >	01.85 - 08.88			/	GAS	210042	CG2906		516004
				♀					

CHEVETTE

	03.75 - 12.85			♂	OIL	201661	T 2903		
				♂	OIL	201675	T 2922		
 	03.75 - 12.85			♂	OIL	201661	T 2903		
				♂	GAS	211674	TG2921		

COMBO

	07.94 - 10.01			♀	GAS	210554	MG2917	600370	516004
				♀	OIL	201679	T 2929		
 Van, Tour	10.01 -			♀	GAS	210566	MG2971 MG2972	600380	516004
				♀	GAS	211699	TG2974		

CORSA

incl. CorsaVan excl. GSI	03.93 - 09.00			♀	GAS	210554	MG2917	600370	516004
				♂	GAS	211671	TG2918		
GSI, GSI 16V	03.93 - 09.00			♀	GAS	210554	MG2917	600370	516004
				♂	GAS	211671	TG2918		
1.0, 1.2 excl. ♀	09.00 -			♀	GAS	210566	MG2971 MG2972	600380	516004
			33A	♂	GAS	211695	TG2967		
1.0, 1.2 ♀	09.00 -			♀	GAS	210566	MG2971 MG2972	600380	516004
			33B	♂	GAS	211698	TG2973		
1.7 Di excl. ♀	09.00 -			♀	GAS	210566	MG2971 MG2972	600380	516004
			33A	♂	GAS	211695	TG2967		
1.7 Di ♀	09.00 -			♀	GAS	210566	MG2971 MG2972	600380	516004
			33B	♂	GAS	211698	TG2973		
1.4 excl. ♀	09.00 -			♀	GAS	210566	MG2971 MG2972	600380	516004
			33B	♂	GAS	211698	TG2973		
1.4 ♀	09.00 -			♀	GAS	210566	MG2971 MG2972	600380	516004
			33B	♂	GAS	211698	TG2973		
1.8, 1.7DTi excl. ♀	09.00 -			♀	GAS	210566	MG2971 MG2972	600380	516004
			33B	♂	GAS	211698	TG2973		
1.8, 1.7DTi ♀	09.00 -			♀	GAS	210566	MG2971 MG2972	600380	516004
			33B	♂	GAS	211698	TG2973		

CORSA MK IV

	07.06 -			♀	GAS	210571	MG2987 MG2988	600500	516004
				♂	GAS	211704	TG2989	600781 600782	

VAUXHALL (GB)

FRONTERA

incl. sport , > Ch. SV720102		03.92 - 02.95			⊖	GAS	211644	HG2861			516004
					⊕	GAS	211676	HG2925			
incl. sport , Ch. SV720103 >		02.95 - 10.98			⊖	GAS	211687	HG2947			516004
					⊕	GAS	211676	HG2925			
incl. sport		11.98 -			⊖	GAS	211692	HG2960			516004
					⊕	GAS	211693	HG2961			

MERIVA

		01.03 - 03.10				GAS	210566	MG2971	MG2972	600380	516004
					⊕	GAS	211699	TG2974			

MONTEREY

		09.91 - 03.95			⊖	GAS	211670	HG2916			516004
					⊕	GAS	211680	HG2930			
		04.95 - 07.98			⊖	GAS	211688	HG2949			516004
					⊕	GAS	211680	HG2930			
		01.98 -			⊖	GAS	211707	HG2999			516004
					⊕	GAS	212001	HG5204			

MOVANO

 2.8T, 3.3T, 3.5T	(E9, F9, J9)	07.98 -			⊕	GAS	211789	HG3411			
					⊕	GAS	211790	HG3412			
3.5T	(H9, U9)	07.98 -			⊕	GAS	211789	HG3411			
					⊕	OIL	201791	H 3413			

NOVA

incl. NovaVan excl. GT,GTE, GSI		05.83 - 03.93				GAS	210554	MG2917		600370	516004
					⊖	GAS	211671	TG2918			
GT, GTE, GSI		01.88 - 03.93				GAS	210554	MG2917		600370	516004
					⊖	GAS	211671	TG2918			

OMEGA

2.0, 2.0 16V, 2.2 16V excl.		05.94 - 07.03				GAS	210557	MG2940			516004
					⊖	GAS	211682	TG2933			
2.5 V6, 2.6 V6, 3.0 V6, 3.2 V6, excl. 2.0 DTI, 2.2 DTI, 2.5 TD, 2.5 DTI, Excl.		05.94 - 07.03				GAS	210558	MG2941			516004
		05.94 - 07.03			⊖	GAS	211682	TG2933			
2.0, 2.0 16V, 2.2 16V excl.		05.94 - 07.03				GAS	210557	MG2940			516004
					⊖	GAS	211683	TG2935			
2.5 V6, 2.6 V6, 3.0 V6, 3.2 V6, excl. 2.0 DTI, 2.2 DTI, 2.5 TD, 2.5 DTI, excl.		05.94 - 07.03				GAS	210558	MG2941			516004
		05.94 - 07.03			⊖	GAS	211683	TG2935			

RASCAL

		1986 -				OIL	200178	M 0709	M 0708		
					⊕	OIL	201314	H 0706			
		1986 -				OIL	200178	M 0709	M 0708		
						OIL	201315	H 0707			

VAUXHALL (GB)

ROYALE



excl. 15		02.78 - 08.87			/	GAS	210045	CG2923			
					0						

SENATOR

excl. 15		02.78 - 08.87			/	GAS	210045	CG2923			
					0						
excl. 3.0 24V, 15		09.87 - 04.94			15	GAS	210555	MG2932			
					0	GAS	211682	TG2933			
3.0 24V excl. 15		09.87 - 04.94			15	GAS	210556	MG2934			
					0	GAS	211682	TG2933			

SINTRA

		11.96 - 04.99			15	GAS	210563	MG2958			516004
				excl. 15	0	GAS	211691	HG2959			

TIGRA

1.4 16V, 1.6 16V		07.94 - 12.00			15	GAS	210554	MG2917	600370		516004
					0	GAS	211671	TG2918			

VECTRA MK I

1.6, 1.8, 2.0		08.95 - 08.02			15	GAS	210560	MG2945	MG2948	600380	516004
					15	GAS	211130	SG2946			516010
1.7 TD, 2.0 DTi		01.96 - 08.02			15	GAS	210561	MG2951	MG2952	600380	
2.5 V6		08.95 - 08.02			15	GAS	211130	SG2946			
1.6, 1.8, 2.0		08.95 - 08.02			15	GAS	210560	MG2945	MG2948	600380	516004
				excl. 15	15	GAS	211130	SG2946			
1.7 TD, 2.0 DTi		08.95 - 08.02			15	GAS	210561	MG2951	MG2952	600380	516004
2.5 V6		08.95 - 08.02		excl. 15	15	GAS	211131	SG2957			

VECTRA MK II

excl. 3.0 CDTi excl. 15, 15		04.02 -			15	GAS	210567	MG2975	MG2976	600770	516004
					0	GAS	211700	TG2979			
excl. 3.0 CDTi		04.02 -			15	GAS	210568	MG2977	MG2978	600770	516004
					0	GAS	211701	TG2980			

VIVARO

		08.01 -			15	GAS	210648	MG3442		600150	516004
					0	GAS	211804	TG3443			

ZAFIRA

excl. 2.0 Turbo OPC		04.99 - 07.05			15	GAS	210564	MG2963	MG2962	600380	516004
					0	GAS	211694	TG2964			

ZAFIRA MK II

		07.05 -			15	GAS	210569	MG2983	MG2982	600160	516004
					0	GAS	211703	TG2986			

VOLKSWAGEN (D)

BORA

excl. 2.3 V5 excl.	(1J2)	10.98 - 05.05		4A		OIL	200772	M 4441	600270	516004
						GAS	210772	MG4441		
						GAS	211252	TG0320		
2.3 V5 	(1J2)	10.98 - 05.05		4B		OIL	200124	M 0316	600270	516004
						GAS	210124	MG0316		
			10.98 - 05.05			GAS	211252	TG0320	600290	516010
4motion 4X4 excl. > Ch. 1J-X-999000	(1J2)	10.98 - 04.99		4B		OIL	200124	M 0316	600270	516004
						GAS	210124	MG0316		
						GAS	211846	TG3809		
4motion 4X4 excl. Ch. 1J-X-999001 >	(1J2)	05.99 - 05.05		4B		GAS	210125	MG0327	600270	516004
						GAS	211846	TG3809		
4motion 4X4 	(1J2)	05.99 - 05.05		4B		GAS	210125	MG0327	600270	516004
						GAS	211914	TG4448		
excl. 2.3 V5 excl. , 4motion 4X4	(1J6)	05.99 - 05.05		4A		OIL	200772	M 4441	600270	516004
						GAS	210772	MG4441		
						GAS	211913	TG4444		
2.3 V5, excl. 4motion 4X4	(1J6)	05.99 - 05.05		4B		GAS	210124	MG0316	600270	516004
						GAS	211913	TG4444		
4motion 4X4 excl.	(1J2)	05.99 - 05.05		4B		GAS	210125	MG0327	600270	516004
						GAS	211846	TG3809		
4motion 4X4 	(1J2)	05.99 - 05.05		4B		GAS	210125	MG0327	600270	516004
						GAS	211914	TG4448		

BEETLE

Assale rigido	(5C1)	04.11 -		5B		GAS	210127	MG0343	600430	516004
						GAS	210776	MG4455		
						GAS	211916	TG4456		
Assale multilink	(5C1)	04.11 -		5B		GAS	210127	MG0343	600430	516004
						GAS	210776	MG4455		
						GAS	211916	TG4456		
Assale rigido	(5C7)	12.11 -		5B		GAS	210127	MG0343	600430	516004
						GAS	210776	MG4455		
						GAS	211916	TG4456		
Assale multilink	(5C7)	12.11 -		5B		GAS	210127	MG0343	600430	516004
						GAS	210776	MG4455		
						GAS	211916	TG4456		

CADDY I

	(14)	08.82 - 07.92				OIL	200077	C 4401		516004
						GAS	210077	CG4401		
						OIL	201413	T 1425		

CADDY II

	(9K9A)	11.95 - 01.04		40C		OIL	200771	M 4432	600050	516004
						GAS	210771	MG4432		
						OIL	201840	T 3713		
	(9U7)	06.96 - 12.00								

VOLKSWAGEN (D)

CADDY III

excl. Maxi	(2KA)	03.04 -		5A		GAS	210776	MG4455	600430	516007
				5B		GAS	210127	MG0343		516004
						GAS	211918	TG4460		
incl. maxi excl. 4WD,	(2K_, 2C_)	08.10 - 05.15 04.04 - 05.15		5A		GAS	210127	MG0343	600430	516007
				5B		GAS	210776	MG4455		516004
						GAS	211926	TG4475		
incl. maxi, 4WD excl.	(2K_, 2C_)	05.08 - 05.15		5A		GAS	210127	MG0343	600430	516007
				5B		GAS	210776	MG4455		516004
						GAS	211927	TG4476		

CADDY IV

incl. maxi excl. 4WD,	(SA_)	05.15 -		5B		GAS	210127	MG0343	600430	516007
				5A		GAS	210776	MG4455		516004
						GAS	211918	TG4460		
						GAS	211918	TG4460		

CORRADO

1.8 16V, 1.8 G60 2.0, 2.0 16V	(53I)	08.87 - 12.95 08.91 - 12.95				GAS	210078	CG4403	600040	516004
				40E		GAS	210767	MG4409		
2.9 VR6	(53I)	09.91 - 12.95		40B		GAS	210769	MG4411	600040	516004
						GAS	211175	SG4406	600700	

CRAFTER

30 excl. H.D.		04.06 -				GAS	210507	MG2575	600220	516007
						GAS	211584	HG2576		
30 incl. H.D.		04.06 -				GAS	210509	MG2579	600220	516007
35 excl. H.D. excl.		04.06 -				GAS	210507	MG2575	600220	516007
						GAS	211584	HG2576		
35 incl. H.D. incl.		04.06 -				GAS	210507	MG2575	600220	516007
50 incl. H.D. excl.		04.06 -				GAS	210509	MG2579	600220	516007
						GAS	211586	HG2580		
50 incl.		04.06 -				GAS	210509	MG2579	600220	516007

DERBY

	(86, 86C, 80)	02.77 - 12.84				OIL	200002	C 0301		516004
						GAS	210002	CG0301		
						OIL	200993	S 0302		
						GAS	210993	SG0302		

EOS

	(1F7, 1F8)	06.06 - 08.15		5A		GAS	210776	MG4455	600430	516007
				5B		GAS	210127	MG0343		516004
						GAS	211921	TG4466		516010

VOLKSWAGEN (D)

FOX

🚗 1.2, 1.4i, 1.4 TDi	(5Z1)	04.05 -		4A		GAS	210694	MG3810	600350	516004
						GAS	211920	TG4465	600290	516010

GOLF I

🚗 excl. 🚗, H.D.	(17)	04.74 - 05.77				OIL	200077	C 4401		516004
						GAS	210077	CG4401		
						OIL	201173	S 4402		
						GAS	211173	SG4402		
🚗 excl. 🚗, H.D.	(17)	05.77 - 08.83				OIL	200077	C 4401		516004
						GAS	210077	CG4401		
						OIL	201173	S 4402		
🚗	(155)	01.79 - 08.93				GAS	210077	CG4401		516004
						GAS	211173	SG4402		

GOLF II

🚗 N.D. excl. 1.8 GTI 16V, 1.8 G60, Syncro 4X4, Country	(19E, 1G1)	09.83 - 12.89		40A		OIL	200078	C 4403	600040	516004
						OIL	200768	M 4410		
						GAS	210078	CG4403		
						GAS	210768	MG4410		
						OIL	201174	S 4404		
						GAS	211174	SG4404		
🚗 excl. 1.8 GTI 16V, 1.8 G60, Syncro 4X4, Country	(19E, 1G1)	01.90 - 08.91		40A		OIL	200078	C 4403	600040	516004
						OIL	200768	M 4410		
						GAS	210078	CG4403		
						GAS	210768	MG4410		
						OIL	201174	S 4404		
						GAS	211174	SG4404		
🚗 1.8 GTI 16V	(19E, 1G1)	09.83 - 12.89				GAS	210079	CG4405	600040	516004
						GAS	211175	SG4406	600700	516010
🚗 1.8 GTI 16V	(19E, 1G1)	01.90 - 08.91		40D		GAS	210766	MG4408	600040	516004
						GAS	211175	SG4406	600700	516010
🚗 1.8 G60 excl. Syncro 4X4	(19E, 1G1)	04.90 - 08.91		40D		GAS	210767	MG4409	600040	516004
						GAS	211175	SG4406	600700	516010
🚗 1.8 Syncro 4X4 excl. Country	(19E, 1G1)	02.86 - 12.89				OIL	200078	C 4403	600040	516004
						GAS	210078	CG4403		
						GAS	211161	SG3710		
🚗 1.8 Syncro 4X4 excl. Country, Rallye	(19E, 1G1)	01.90 - 08.91		40A		OIL	200768	M 4410	600040	516004
						GAS	210768	MG4410		
						GAS	211161	SG3710		

GOLF III

🚗 excl. 1.8 GT, 1.9 TD/TDI, GTI, VR6, Syncro 4X4 > Ch. 1H SW062 538 > Ch. 1H SB019 475	(1H1)	09.91 - 08.94		40A		OIL	200768	M 4410	600040	516004
						GAS	210768	MG4410		
						OIL	201174	S 4404		
						GAS	211174	SG4404		

VOLKSWAGEN (D)

excl. 1.8 GT, 1.9 TD/TDI, GTI, VR6, Syncro 4X4 Ch. 1H SW062 539 > Ch. 1H SB019 476 >	(1H1)	09.94 - 08.97		40C		OIL	200771	M 4432	600050	516004	
						GAS	210771	MG4432			
						OIL	201174	S 4404			600700
						GAS	211174	SG4404			600700
1.8 GT, 1.9 TD/TDI > Ch. 1H SW062 538 > Ch. 1H SB019 475	(1H1)	09.91 - 08.94		40A		GAS	210768	MG4410	600040	516004	
						GAS	211174	SG4404	600700	516010	
1.8 GT, 1.9 TD/TDI Ch. 1H SW062 539 > Ch. 1H SB019 475 >	(1H1)	09.94 - 08.97		40C		GAS	210771	MG4432	600050	516004	
						GAS	211174	SG4404	600700	516010	
1.8, 2.0 Syncro 4X4 > Ch. 1H SW062 538 > Ch. 1H SB019 475	(1H1)	01.93 - 08.94 01.93 - 08.94		40A		OIL	200768	M 4410	600040	516004	
						GAS	210768	MG4410			
						GAS	211161	SG3710			600700
1.8, 2.0 Syncro 4X4 Ch. 1H SW062 539 > Ch. 1H SB019 475 >	(1H1)	09.94 - 08.97 09.94 - 08.97		40C		OIL	200771	M 4432	600050	516004	
						GAS	210771	MG4432			
						GAS	211161	SG3710			600700
2.0 GTI, 2.0 GTI 16V	(1H1)	09.91 - 08.97		40B		GAS	210769	MG4411	600040	516004	
						GAS	211175	SG4406	600700	516010	
2.8 VR6	(1H1)	09.91 - 08.97		40B		GAS	210769	MG4411	600040	516004	
						GAS	211175	SG4406	600700	516010	
excl. 2.0, 2.8 VR6 > Ch. 1H SW062538 > Ch. 1H SB019475	(1H5)	09.93 - 08.94		40A		OIL	200768	M 4410	600040	516004	
						GAS	210768	MG4410			
						GAS	211179	SG4437			600700
excl. 2.0, 2.8 VR6 Ch. 1H SW062539 > Ch. 1H SB019475 >	(1H5)	09.94 - 04.99		40C		OIL	200771	M 4432	600050	516004	
						GAS	210771	MG4432			
						GAS	211179	SG4437			600700
2.0	(1H5)	09.93 - 04.99		40B		GAS	210769	MG4411	600040	516004	
						GAS	211179	SG4437	600700	516010	
1.6, 1.8, 1.9 TDI	(1E7)	09.93 - 08.94		40A		OIL	200768	M 4410	600040	516004	
						GAS	210768	MG4410			
						OIL	201174	S 4404			600700
						GAS	211174	SG4404			
1.6, 1.8, 1.9 TDI	(1E7)	09.94 - 05.98		40C		OIL	200771	M 4432	600050	516004	
						GAS	210771	MG4432			
						OIL	201174	S 4404			600700
						GAS	211174	SG4404			
2.0	(1E7)	09.93 - 05.98		40B		GAS	210769	MG4411	600040	516004	
						GAS	211174	SG4404	600700	516010	

GOLF IV

1.4, 1.6, 2.0, 1.9 SDI, 1.9 TDI excl. 4motion 4X4, 16"	(1J1)	08.97 - 06.05		4A		OIL	200772	M 4441	600270	516010
						GAS	210772	MG4441		
						GAS	211251	TG0317		
1.4, 1.6, 2.0, 1.9 SDI, 1.9 TDI 16"	(1J1)	08.97 - 06.05		4B		GAS	210124	MG0316	600270	516004
						GAS	211252	TG0320	600290	516010
1.8, 1.8 Turbo, 2.3 V5, 2.8 V6 excl. 4motion 4X4, 16"	(1J1)	08.97 - 06.05		4B		GAS	210124	MG0316	600270	516004
						GAS	211252	TG0320	600290	516010
4motion 4X4 excl. 16"	(1J1)	07.98 - 06.05		4B		GAS	210124	MG0316	600270	516004
						GAS	211256	TG0329	600290	516010
4motion 4X4 excl. 16"	(1J1)	06.99 - 10.03		4B		GAS	210125	MG0327	600270	516004
						GAS	211256	TG0329	600290	516010

VOLKSWAGEN (D)

1.4, 1.6, 1.9 SDI, 1.9TDI excl. 16"	(1J5)	05.99 - 06.06		4A		OIL	200772	M 4441	600270	516004
						GAS	210772	MG4441		
						GAS	211913	TG4444		
1.4, 1.6, 1.9 SDI, 1.9 TDI excl. 16"	(1J5)	05.99 - 06.06		4B		GAS	210124	MG0316	600270	516004
						GAS	211913	TG4444		
1.8, 1.8 Turbo, 2.3 V5 excl. 16"	(1J5)	05.99 - 06.06		4B		GAS	210124	MG0316	600270	516004
						GAS	211913	TG4444		

GOLF V

excl. GTI,	(1K1)	10.03 - 12.08		5A		GAS	210776	MG4455	600430	516007	
						GAS	210127	MG0343			516004
						GAS	211916	TG4456			516010
	(1K1)	01.05 - 12.08		5A		GAS	210777	MG4457	600430	516007	
						GAS	210128	MG0345			516004
						GAS	211260	TG0344			516010
Plus	(5M)	01.05 -		5A		GAS	210776	MG4455	600430	516007	
						GAS	210127	MG0343			516004
						GAS	211916	TG4456			516010
excl.	(1K5)	06.07 -		5A		GAS	210776	MG4455	600430	516007	
						GAS	210127	MG0343			516004
						GAS	211916	TG4456			516010
	(1K5)	06.07 -		5A		GAS	210777	MG4457	600430	516007	
						GAS	210128	MG0345			516004
						GAS	211260	TG0344			516010

GOLF VI

excl.	(5K1, AJ5)	10.08 - 07.09 -		5A		GAS	210776	MG4455	600430	516007	
						GAS	210127	MG0343			516004
						GAS	211916	TG4456			516010
incl.	(5K1, AJ5)	10.08 - 07.09 -		5A		GAS	210777	MG4457	600430	516007	
						GAS	210128	MG0345			516004
						GAS	211260	TG0344			516010

GOLF VII

excl. 4X4, S3,	(5G1, BA5)	11.12 - 04.13 -		5A		GAS	210785	MG4474		516007	
						GAS	210784	MG4471			516004
						GAS	211924	TG4472			516010
incl. 4X4 excl. S3,	(5G1, BA5)	11.12 - 04.13 -		5A		GAS	210785	MG4474		516007	
						GAS	210784	MG4471			516004
						GAS	211925	TG4473			516010

JETTA

	(17, 16)	01.73 - 05.77				OIL	200077	C 4401		516004	
						GAS	210077	CG4401			
						OIL	201173	S 4402			516010
						GAS	211173	SG4402			
	(17, 16)	06.77 - 08.83				OIL	200077	C 4401		516004	
						GAS	210077	CG4401			
						OIL	201173	S 4402			516010
						GAS	211173	SG4402			

VOLKSWAGEN (D)

excl. 1.8 GTI 16V, Syncro 4X4, H.D.	(19E, 162)	09.83 - 12.92		40A		OIL	200078	C 4403	600040	516004
						OIL	200768	M 4410		
						GAS	210078	CG4403		
						GAS	210768	MG4410		
						OIL	201174	S 4404	600700	516010
		GAS	211174	SG4404						
1.8 GTI 16V	(19E, 162)	09.83 - 12.89				GAS	210079	CG4405	600040	516004
						GAS	211175	SG4406	600700	516010
1.8 GTI 16V	(19E, 162)	01.90 - 12.92		40C		GAS	210766	MG4408	600040	516004
						GAS	211175	SG4406	600700	516010
1.8 Syncro 4X4	(19E, 162)	08.87 - 12.89				OIL	200078	C 4403	600040	516004
						GAS	210078	CG4403		
						GAS	211161	SG3710	600700	516010
1.8 Syncro 4X4	(19E, 162)	01.90 - 07.91		40A		OIL	200768	M 4410	600040	516004
						GAS	210768	MG4410		
						GAS	211161	SG3710	600700	516010
excl.	(1K2)	09.05 -		5A		GAS	210776	MG4455	600430	516004
				5B		GAS	210127	MG0343		
						GAS	211916	TG4456		516010
	(162)	04.10 -		5A		GAS	210776	MG4455	600430	516004
				5B		GAS	210127	MG0343		
						GAS	211916	TG4456		516010

LT SERIES

LT 28, LT 28 D, LT 31, LT 31 D, LT 35, LT 35 D	(281, 363)	04.75 - 12.82				OIL	201903	T 4416		
						OIL	201910	T 4429		
LT 28, LT 28 D, LT 31, LT 31 D, LT 35, LT 35 D	(281, 363)	12.82 - 12.96				OIL	201903	T 4416		
						OIL	201904	H 4417		
LT 40, LT 40 D, LT 45, LT 45 D	(291, 293, 512, 909)	01.75 - 12.82				OIL	201911	H 4433		
						OIL	201910	T 4429		
LT 40, LT 40 D, LT 40 TD LT 45, LT 45 D, LT 45 TD LT 55, LT 55 D, LT 55 TD 4X2, 4X4	(291, 293, 512, 909)	01.83 - 12.96 08.85 - 12.96 08.85 - 12.96				OIL	201911	H 4433		
excl. LT 46	(2DM)	04.96 -				GAS	210779	MG4461		
						GAS	211565	TG2542		
LT46	(2DX0AE/FE)	04.96 -				GAS	210498	MG2552		
						OIL	201566	H 2543		

LUPO

	(6X1, 6E1)	09.98 - 07.05		40C		OIL	200771	M 4432	600050	516004
						GAS	210771	MG4432		
						GAS	211841	TG3714		

MULTIVAN T5

	(7H, 7E)	04.03 -				GAS	210781	MG4463		516004
						GAS	211919	HG4464		

MULTIVAN T6

excl.	(SGF, SGM, SGN)	04.15 -				GAS	211919	HG4464		
-------	-----------------	---------	--	--	--	-----	--------	--------	--	--

VOLKSWAGEN (D)

NEW BEETLE

	(9C1, 1C1)	01.98 -		4B		GAS	210124	MG0316	600270	516004
						GAS	211252	TG0320	600290	516010
	(1Y7)	01.03 -		4B		GAS	210124	MG0316	600270	516004
						GAS	211252	TG0320	600290	516010

PASSAT I

	(32, 33)	05.73 - 09.80				OIL	200003	C 0303		516004
						OIL	201249	T 0305		

PASSAT II

	(32B)	10.80 - 06.89				GAS	210004	CG0306		516004
						GAS	211176	SG4418		516010

PASSAT III

excl. 2.8 VR6, Syncro 4X4, □ excl. 2.8 VR6, Syncro, □	(3A2, 351) (3A5, 351)	02.88 - 07.91 02.88 - 07.91		40E		OIL	200080	C 4409	600040	516004
						OIL	200767	M 4409		
						GAS	210080	CG4409		
						GAS	210767	MG4409		
						OIL	201177	S 4420		
						GAS	211177	SG4420		
excl. 2.8 VR6, Syncro 4X4, □ > Ch. 026435	(3A2, 3A5, 351)	08.91 - 05.97		40D		OIL	200767	M 4409	600040	516004
						GAS	210767	MG4409		
						OIL	201177	S 4420		
						GAS	211177	SG4420		
excl. 2.8 VR6, Syncro 4X4, □ Ch. 026436 >	(3A2, 3A5, 351)	08.91 - 05.97		40F		OIL	200770	M 4430	600040	516004
						GAS	210770	MG4430		
						OIL	201177	S 4420		
						GAS	211177	SG4420		
2.8 VR6 excl. □	(3A2, 3A5, 351)	08.91 - 08.96		40F		GAS	210770	MG4430	600040	516004
						GAS	211177	SG4420		
Syncro 4X4 excl. □ Syncro 4X4 excl. □	(3A2, 351) (3A5, 351)	08.88 - 07.91 08.88 - 07.91		40E		OIL	200080	C 4409	600040	516004
						OIL	200767	M 4409		
						GAS	210080	CG4409		
						GAS	210767	MG4409		
						GAS	211178	SG4421		
Syncro 4X4 excl. □ > Ch. 026435	(3A2, 351)	08.91 - 08.96		40E		OIL	200767	M 4409	600040	516004
						GAS	210767	MG4409		
						GAS	211178	SG4421		
Syncro 4X4 excl. □ > Ch. 026435	(3A5, 351)	08.91 - 12.92		40E		OIL	200767	M 4409	600040	516004
						GAS	210767	MG4409		
						GAS	211178	SG4421		
Syncro 4X4 excl. □ Ch. 026436 >	(3A2, 351)	01.92 - 08.96		40F		OIL	200770	M 4430	600040	516004
						GAS	210770	MG4430		
						GAS	211178	SG4421		

PASSAT IV

1.6, 1.8, 1.8 Turbo, 2.0, 1.9 TDI excl. Syncro 4X4 > Ch. 3B-YE121221	(3B2)	08.96 - 09.99				GAS	210999	SG0314	600060	516001
						GAS	211253	TG0323		516010

VOLKSWAGEN (D)

2.3 VR5, 2.8 V6, 2.5 V6 TDI excl. Syncro 4X4 > Ch. 3B-YE121221	(3B2)	08.96 - 09.99				GAS	211001	SG0321	600060	516001
						GAS	211253	TG0323		516010
1.6, 1.8, 2.0, 1.8 Turbo, 1.9 TDI, 2.3 VR5 Excl. Syncro 4X4 Ch. 3B-YE121222 >	(3B3)	09.99 - 12.05		N.D.		GAS	211008	SG0339	600060	516001
				H.D.		GAS	211009	SG0340		
						GAS	211253	TG0323		516010
2.5 V6 TDI, 2.8 V6 Excl. Syncro 4X4 Ch. 3B-YE121222 >	(3B3)	09.99 - 12.05				GAS	211009	SG0340	600060	516001
						GAS	211253	TG0323		516010
1.6, 1.8, 2.0, 1.8 Turbo, 1.9 TDI, 2.3 VR5 Syncro, 4motion 4X4 Ch. 3B-YE121222 >	(3B3)	09.99 - 12.05		N.D.		GAS	211008	SG0339	600060	516001
				H.D.		GAS	211009	SG0340		
						GAS	211010	SG0341		516010
2.5 V6 TDI, 2.8 V6 Syncro, 4motion 4X4 Ch. 3B-YE121222 >	(3B3)	09.99 - 12.05				GAS	211009	SG0340	600060	516001
						GAS	211010	SG0341		516010
1.6, 1.8, 1.8 Turbo, 2.0, 1.9 TDI excl. Syncro 4X4 > Ch. 3B-YE121221	(3B5)	06.97 - 09.99				GAS	210999	SG0314	600060	516001
						GAS	211253	TG0323		516010
2.3 VR5, 2.8 V6, 2.5 V6 TDI excl. Syncro 4X4 > Ch. 3B-YE121221	(3B5)	06.97 - 09.99				GAS	211001	SG0321	600060	516001
						GAS	211253	TG0323		516010
1.6, 1.8, 2.0, 1.8 Turbo, 1.9 TDI, 2.3 VR5 Excl. Syncro 4X4 Ch. 3B-YE121222 >	(3B6)	09.99 - 12.05		N.D.		GAS	211008	SG0339	600060	516001
				H.D.		GAS	211009	SG0340		
						GAS	211253	TG0323		516010
2.5 V6 TDI, 2.8 V6 Excl. Syncro 4X4 Ch. 3B-YE121222 >	(3B6)	09.99 - 12.05				GAS	211009	SG0340	600060	516001
						GAS	211253	TG0323		516010
1.6, 1.8, 2.0, 1.8 Turbo, 1.9 TDI, 2.3 VR5 Syncro, 4motion 4X4 Ch. 3B-YE121222 >	(3B6)	09.99 - 12.05		N.D.		GAS	211008	SG0339	600060	516001
				H.D.		GAS	211009	SG0340		
						GAS	211010	SG0341		516010
2.5 V6 TDI, 2.8 V6 Syncro, 4motion 4X4 Ch. 3B-YE121222 >	(3B6)	09.99 - 12.05				GAS	211009	SG0340	600060	516001
						GAS	211010	SG0341		516010

PASSAT V

excl.	(3C2)	03.05 -				GAS	210776	MG4455	600430	516007
						GAS	211916	TG4456		516010
	(3C2)	03.05 -				GAS	210777	MG4457	600430	516007
						GAS	211260	TG0344		516010

PASSAT CC

excl.		06.08 -				GAS	210776	MG4455	600430	516007
						GAS	211916	TG4456		516010
incl.		06.08 -				GAS	210777	MG4457	600430	516007
						GAS	211260	TG0344		516010

PASSAT VI

, excl.	(362, 365)	08.10 -				GAS	210776	MG4455	600430	516007
						GAS	211916	TG4456		516010
, incl.	(362, 365)	08.10 -				GAS	210777	MG4457	600430	516007
						GAS	211260	TG0344		516010
Alltrack excl. ,	(365)	01.12 - 12.14				GAS	210776	MG4455	600430	516007
						GAS	211916	TG4456		516010
Alltrack incl. ,	(365)	01.12 - 12.14				GAS	210777	MG4457	600430	516007
						GAS	211260	TG0344		516010

VOLKSWAGEN (D)

PASSAT VII

excl. , Alltrack	(362, 365)	08.14 -				GAS	210785	MG4474		516007
-------------------	------------	---------	--	--	--	-----	--------	--------	--	--------

POLO I / II

excl. 1.3 G40	(86, 86C, 80)	03.75 - 08.94				OIL	200002	C 0301		
						GAS	210002	CG0301		
						OIL	200993	S 0302		
						GAS	210993	SG0302		
1.3 G40	(86, 86C, 80)	01.87 - 08.94								

POLO III

excl. 1.6 16V GTI	(6N1, 6N2)	09.94 - 06.96		40C		OIL	200771	M 4432	600050	516004
						GAS	210771	MG4432		
						OIL	201180	S 4438	600700	516010
						GAS	211180	SG4438		
excl. 1.6 16V GTI	(6N1, 6N2)	07.96 - 11.01		40C		OIL	200771	M 4432	600050	516004
						GAS	210771	MG4432		
						OIL	201180	S 4438	600700	516010
						GAS	211180	SG4438		
1.6 16V GTI	(6N1, 6N2)	09.94 - 11.01								516004
					OIL	201180	S 4438	600700	516010	
					GAS	211180	SG4438			
					GAS	211180	SG4438			
Classic, Flight	(6KV2)	09.94 - 06.96		40C		OIL	200771	M 4432	600050	516004
						GAS	210771	MG4432		
						OIL	201161	S 3710	600700	516010
						GAS	211161	SG3710		
Classic, Flight	(6KV2)	07.96 - 09.01		40C		OIL	200771	M 4432	600050	516004
						GAS	210771	MG4432		
						OIL	201161	S 3710	600700	516010
						GAS	211161	SG3710		
Variant	(6KV5)	04.97 - 09.01		40C		OIL	200771	M 4432	600050	516004
						GAS	210771	MG4432		
						OIL	201163	S 3718	600700	516010
						GAS	211163	SG3718		
Caddy	(6NF)	10.94 -		40C		OIL	200771	MG4432	600050	516004
						GAS	210771	MG4432		
						GAS	211840	TG3713		
						GAS	211840	TG3713		

POLO IV

1.2, 1.4 16V, 1.4 FSI 1.4 TDI, 1.9 SDI, 1.9 TDI	(9N)	10.01 - 11.09		4A		OIL	200688	M 3715	600350	516004
	(9N)				GAS	210688	MG3715			
						GAS	211915	TG4451	600290	516010

POLO V

excl. 2.0 R WRC	(6R)	06.09 -				GAS	210689	MG3719	600270	516004
						GAS	211843	TG3720	600290	516010

VOLKSWAGEN (D)

SANTANA

	(32B)	08.81 - 12.84			/	OIL	200004	C 0306		516004
					/	GAS	210004	CG0306		
					/	GAS	211176	SG4418		

SCIROCCO

	excl. 1.8 GT 16 V	(53, 53B)	02.74 - 07.92			/	OIL	200077	C 4401		
						/	GAS	210077	CG4401		
						/	OIL	201173	S 4402		
						/	GAS	211173	SG4402		
	excl. 2.0 R	(137)	09.08 -		5A	/	GAS	210776	MG4455	600430	516007
					5A	/	GAS	210127	MG0343		516004
						⊕	GAS	211916	TG4456		516010
	incl. 2.0 R	(137)	09.08 -		5A	/	GAS	210777	MG4457	600430	516007
					5B	/	GAS	210128	MG0345		516004
						⊕	GAS	211260	TG0344		516010

SHARAN

	(7M8, 7M9, 7M6)	02.95 - 03.10			/	GAS	210314	MG1478	600800	516004
					⊕	GAS	211429	TG1479		
	(7N)	05.10 -			/	GAS	210776	MG4455	600430	516007
					⊕	GAS	211916	TG4456		

TARO

	4X2		04.89 - 03.97			⊕	GAS	211879	HG4237		
						⊕	GAS	211625	HG2702		
	4X4 excl. Extra Cabin		04.89 - 03.97			⊕	GAS	211882	HG4241		
						⊕	GAS	211883	HG4242		
	4X4 Extra Cabin		04.89 - 03.97			⊕	GAS	211884	HG4243		
						⊕	GAS	211883	HG4242		

TIGUAN

	excl. 2.0 R	(5N)	09.07 -			/	GAS	210782	MG4467	600430	516007
						⊕	GAS	211922	TG4468		516010

TOURAN

	excl. 2.0 R, 2.0 TDI	(1T)	02.03 - 05.10			/	GAS	210778	MG4458	600430	516007
						⊕	GAS	211917	TG4459		516010

TOURAN II

		(1T3)	05.10 - 05.15			/	GAS	210778	MG4458	600430	516007
						⊕	GAS	211917	TG4459		516010

TOURAN III

	assale multilink	(5T1)	09.15 -			/	GAS	210785	MG4474		516007
						⊕	GAS	211925	TG4473		516010

VOLKSWAGEN (D)

TYPE I (MAGGIOLINO / BEETLE / COCINELLE / KÄFER / KEVER)

1200, 1200 Mexico, 1300, 1500		08.65 - 12.79			$\frac{1}{2}$	OIL	201901	T 4412		
					$\frac{1}{2}$	GAS	211902	TG4413		
1302, 1303		01.70 - 07.73			/	OIL	200081	C 4414		
					$\frac{1}{2}$	GAS	211902	TG4413		
1303		08.73 - 12.79			/	GAS	210082	CG4415		
					$\frac{1}{2}$	GAS	211902	TG4413		

TYPE II TRANSPORTER

		01.55 - 07.67			$\frac{1}{2}$	GAS	211902	TG4413		
					$\frac{1}{2}$	GAS	211902	TG4413		
		08.67 - 07.69								
					$\frac{1}{2}$	OIL	201905	T 4422		
		08.69 - 12.79			$\frac{1}{2}$	OIL	201906	T 4423		
					$\frac{1}{2}$	OIL	201905	T 4422		
excl. Syncro 4X4		01.80 - 12.90			$\frac{1}{2}$	OIL	201907	H 4424		
					$\frac{1}{2}$	OIL	201908	T 4425		

TYPE III 1500 / 1600

1500, 1600	(31)	04.61 - 03.75			$\frac{1}{2}$	GAS	211902	TG4413		
					$\frac{1}{2}$	GAS	211902	TG4413		

TYPE IV / CARAVELLE / TRANSPORTER

		09.90 - 12.93			$\frac{1}{2}$	OIL	201912	H 4443		
					$\frac{1}{2}$	OIL	201909	H 4427		
		01.94 - 06.03			$\frac{1}{2}$	OIL	201912	H 4443		
					$\frac{1}{2}$	OIL	201909	H 4427		

TYPE V / TRANSPORTER

		04.03 -			$\frac{1}{2}$	GAS	210781	MG4463		516007
					$\frac{1}{2}$	GAS	211919	HG4464		

TYPE VI / TRANSPORTER

excl. $\frac{1}{2}$	(SG_SF_)	04.15 -			$\frac{1}{2}$	GAS	210781	MG4463		516007
					$\frac{1}{2}$	GAS	211919	HG4464		

UP

		12.11 -			$\frac{1}{2}$	GAS	210783	MG4469	600270	516004
					$\frac{1}{2}$	GAS	211923	TG4470		516010

VENTO

excl. 1.8 GT, 2.0, 2.8 VR6, 1.9 TD/TDI > Ch. SW062 538 > Ch. SB019 475	(1H2)	11.91 - 08.94		40a	$\frac{1}{2}$	OIL	200768	M 4410	600040	516004	
						GAS	210768	MG4410			
						$\frac{1}{2}$	OIL	201174	S 4404	600700	516010
						$\frac{1}{2}$	GAS	211174	SG4404		
excl. 1.8 GT, 2.0, 2.8 VR6, 1.9 TD/TDI Ch. SW062 539 > Ch. SB019 476 >	(1H2)	09.94 - 09.98		40c	$\frac{1}{2}$	OIL	200771	M 4432	600050	516004	
						GAS	210771	MG4432			
						$\frac{1}{2}$	OIL	201174	S 4404	600700	516010
						$\frac{1}{2}$	GAS	211174	SG4404		

VOLKSWAGEN (D)

1.8 GT, 2.0, 1.9 TD/TDI	(1H2)	01.92 - 09.98		40b		GAS	210769	MG4411	600040	516004
						GAS	211175	SG4406	600700	516010
2.8 VR6	(1H2)	01.92 - 09.98		40b		GAS	210769	MG4411	600040	516004

VOLVO (S)

140 / 160 SERIES

142, 144, 144 S 145 164		08.66 - 08.74			±	OIL	201928	T 4503			
		08.66 - 08.74									
		08.66 - 08.74			∞	OIL	201929	T 4504			

240 / 260 SERIES

excl. Turbo	(P242, P244) (P262, P264, P265)	08.74 - 08.93		41	/	OIL	200083	C 4505			516004
				42	∞	OIL	201930	T 4506			
2.1 Turbo 2.1 Turbo	(P242, P244) (P245)	08.80 - 08.93 08.80 - 08.93		41	/	OIL	200083	C 4505			516004
					∞	OIL	201930	T 4506			

300 SERIES

343, 345 340, 360	(343, 345) (344)	02.76 - 12.82 08.82 - 07.91			/	OIL	200084	C 4507			516004
					+	OIL	201931	T 4508			

400 SERIES

440, 460, 480 1.7 Turbo 480 ES excl. B18E eng. > Ch. 520381	(445, 464)	08.87 - 12.96 04.86 - 12.96			↘	GAS	210786	MG4509			516004
					∞	GAS	211932	TG4510			

740

> Ch. F0081680	(744, 745)	08.83 - 04.84			/	GAS	210085	CG4511			516004
				43	∞	GAS	211933	TG4512			
Ch. F0081681 >	(744, 745)	05.84 - 08.92			/	GAS	210086	CG4513			516004
				43	∞	GAS	211933	TG4512			

760

> Ch. F0081680	(704, 764, 765)	02.82 - 04.84			/	GAS	210085	CG4511			516004
				43 ← →	∞	GAS	211933	TG4512			
Ch. F0081681 >	(704, 764, 765)	05.84 - 08.87			/	GAS	210086	CG4513			516004
				43 ← →	∞	GAS	211933	TG4512			
	(704, 764)	09.87 - 07.92			/	GAS	210086	CG4513			516004
				M.link ← →							
Ch. F0081681 >	(704, 765)	05.84 - 07.92			/	GAS	210086	CG4513			516004
				43 ← →	∞	GAS	211933	TG4512			

780

		01.85 - 08.87			/	GAS	210086	CG4513			516004
				43 ← →	∞	GAS	211933	TG4512			
		09.87 - 07.90			/	GAS	210086	CG4513			516004
				M.link ← →							

850

excl. 2.3 T5, > Ch. 1744999	(LS, LW)	06.91 - 12.96			↘	GAS	210790	MG4528			516004
				excl.	±	GAS	211934	TG4517			
excl. 2.3 T5, Ch. 1745000 >	(LS, LW)	06.91 - 12.96			↘	GAS	210790	MG4528			516004
				excl.	±	GAS	211934	TG4517			

VOLVO (S)

940

, excl. Turbo	(944, 945)	08.90 - 10.98			/	GAS	210086	CG4513			516004
				43	∅	GAS	211933	TG4512			
, Turbo	(944, 945)	08.90 - 10.98			/	GAS	210086	CG4513			516004
				43							

960

> Ch. YV1964...R.048299	(964)	08.90 - 09.94			/	GAS	210086	CG4513			516004
				Multilink							
Ch. YV1964...R.048300 >	(964)	09.94 - 12.96				GAS	210798	MG4546			516004
					∅	GAS	211935	TG4520			
> Ch. YV1965...R.018099	(965)	08.90 - 09.94			/	GAS	210086	CG4513			516004
				43	∅	GAS	211933	TG4512			
Ch. YV1965...R.018100 >	(965)	09.94 - 12.96				GAS	210798	MG4546			516004
					∅	GAS	211937	TG4547			

C30

		10.06 - 12.12				GAS	210799	MG4549	MG4548	600480	516004
					∅	GAS	211938	TG4550			516010

C70 II

		03.06 -				GAS	210799	MG4549	MG4548	600480	516004
					∅	GAS	211938	TG4550			516010

S40 / V40

excl. ,	(VS, VW)	05.95 - 05.99				GAS	210788	MG4519	MG4524		516004
				excl.		GAS	211183	SG4523			516010
excl.	(VS, VW)	05.95 - 05.99				GAS	210789	MG4525	MG4526		516004
				excl.		GAS	211184	SG4527			516010
excl. , T4	(VS, VW)	06.99 - 04.00				GAS	210791	MG4529	MG4530		516004
				excl.		GAS	211183	SG4523			516010
excl. T4	(VS, VW)	06.99 - 04.00				GAS	210792	MG4531	MG4532		516004
				Nivomat							
, 1.9 T4	(VS, VW)	05.97 - 07.00				GAS	210792	MG4531	MG4532		516004
				excl.		GAS	211184	SG4527			516010
excl. 2.0 T4 excl. ,	(VS, VW)	04.00 - 12.03				GAS	210793	MG4533	MG4534		516004
				excl.		GAS	211185	SG4537			516010
excl. , 2.0 T4	(VS, VW)	04.00 - 12.03				GAS	210794	MG4535	MG4536		516004
				Nivomat							516010
, 2.0 T4 excl.	(VS, VW)	08.00 - 12.03				GAS	210794	MG4535	MG4536		516004
				excl.		GAS	211186	SG4538			516010

S40 / V50

S40 V50 excl. 4X4	(MS, MW)	01.04 - 04.04 -				GAS	210799	MG4549	MG4548	600480	516004
					∅	GAS	211938	TG4550			516010

VOLVO (S)

S60

excl. 4X4,		11.00 - 04.10				GAS	210795	MG4539			516004
				excl.		GAS	211936	TG4540			516010

S60 II

excl.		04.10 -				GAS	210801	MG4553	MG4554		516004
						GAS	211940	TG4555			516010

S70 / V70 / C70

S70 excl. 2.3 T5 C70	(LS)	01.97 - 08.00				GAS	210790	MG4528			516004
		01.97 - 08.00		excl.		GAS	211934	TG4517			516010
V70 excl. 2.3 T5	(LV)	01.97 - 02.00				GAS	210790	MG4528			516004
				excl.		GAS	211934	TG4517			516010
V70 excl. 4X4, ,	(LV)	03.00 -				GAS	210795	MG4539			516004
				excl.		GAS	211936	TG4540			516010

S80

excl.	(TS, XY)	05.98 -				GAS	210795	MG4539			516004
				excl.		GAS	211936	TG4540			516010

S80 II

excl.	(AS)	03.06 -				GAS	210801	MG4553	MG4554		516004
						GAS	211940	TG4555			516010

S90

 excl.		01.97 - 05.98				GAS	210798	MG4546			516004
						GAS	211935	TG4520			

V40

T2 GTDi, T4 GTDi, T4 GTDi, T4, T5, D2, D3, D4		03.12 -				GAS	210803	MG4559	MG4558		516004
						GAS	211941	TG4560			516010

V60

excl. ,		04.10 -				GAS	210801	MG4553	MG4554		516004
						GAS	211940	TG4555			516010

V70 III

excl. 4x4, excl. ,	(BW)	08.07 -				GAS	210801	MG4553	MG4554		516004
						GAS	211940	TG4555			516010

V90

 excl.		01.97 - 12.98				GAS	210798	MG4546			516004
						GAS	211937	TG4547			

XC60

excl.	(AS)	05.08 -				GAS	210802	MG4557	MG4556		516004
											516010

VOLVO (S)

XC70

excl. 4x4, excl.		03.00 - 08.07									

XC70 II

excl. 4x4, excl.		08.07 -				GAS	210801	MG4553	MG4554		

XC90

excl. 4x4,		10.02 -				GAS	210800	MG4551		
				excl.		GAS	211939	TG4552		

ZASTAVA (YU)

10

		2007 -				GAS	210141	MG0609	600130	
						GAS	211280	TG0610		

100

101, 128, GTL 55, GTL 65		1970 - 1985				OIL	200243	M 1311		
						OIL	200244	M 1312		
125 P		1974 -				OIL	201378	T 1304		
102		1980 - 1989				OIL	200804	M 4601		
						OIL	200244	M 1312		

1300 / 1500

1300, 1500, 125 PZ		1964 -				OIL	201378	T 1304		

YUGO 300 / 500

311, 511, 313, 513		1970 - 1985				OIL	200243	M 1311		
						OIL	200244	M 1312		

YUGO 35 / 45 / 65

45, 55, 65, 65S		1980 - 1989				OIL	200804	M 4601		
						OIL	200244	M 1312		

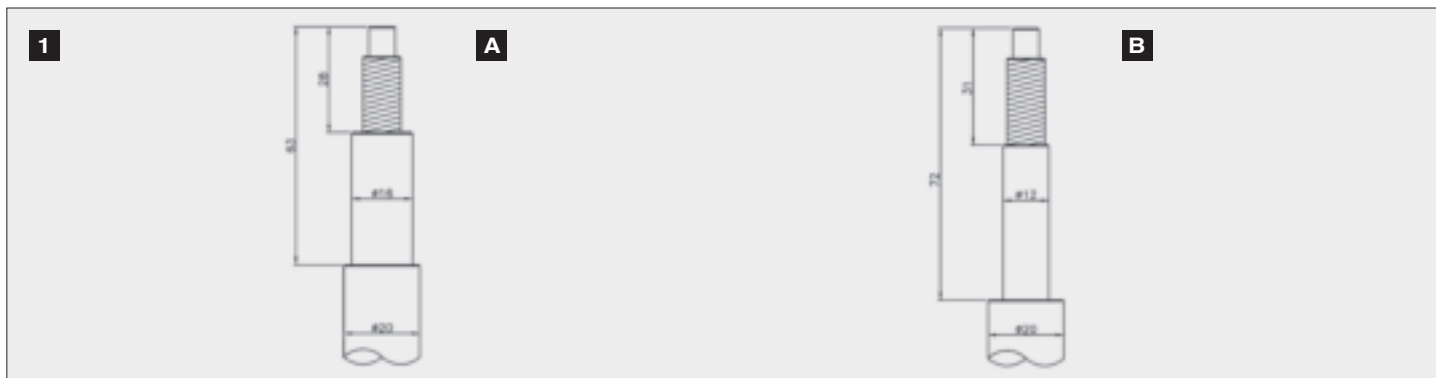

FLORIDA / MIAMI

		1989 -				OIL	200256	M 1335	600570	
						OIL	201174	S 4404	600700	



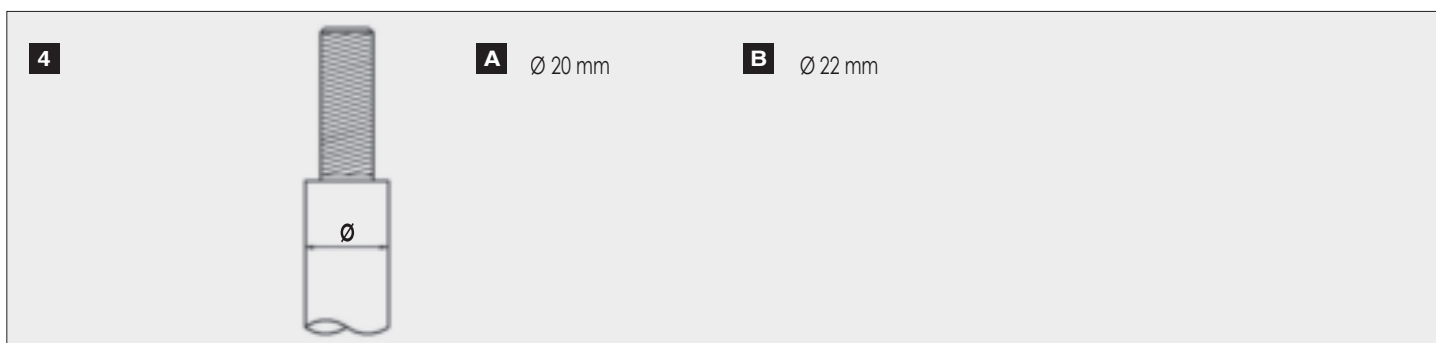
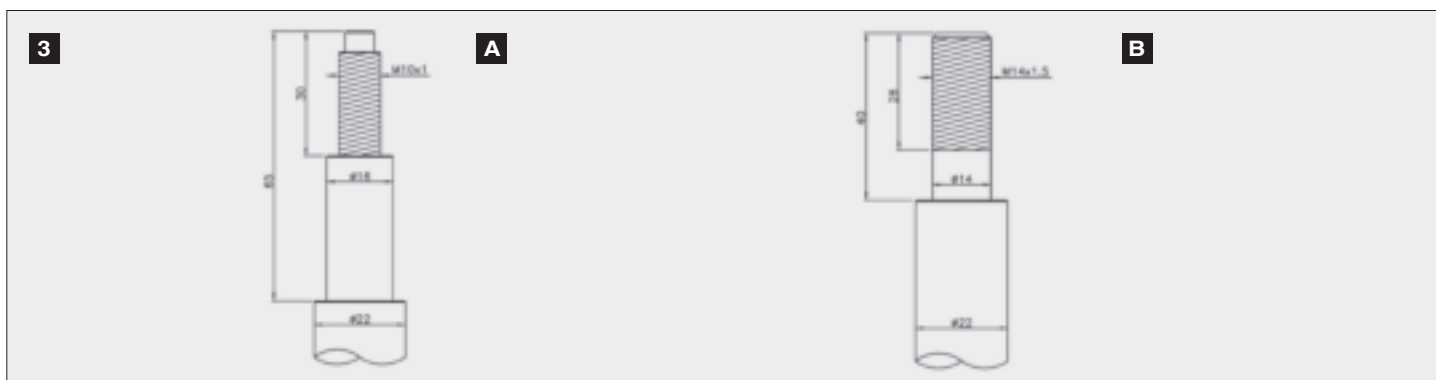

- 2**
- Ⓘ Il cuscinetto a rulli originale deve essere sostituito con un cuscinetto a sfere rif. 142040.
 - Ⓞ The original needle-bearing has to be replaced by bearing Nr. 142040.
 - ⓕ Le roulement à aiguilles d'origine doit être remplacé par un roulement à billes réf. 142040.
 - ⓓ Beim Einsatz von Federbeinen, muß das vorhandene Naddellager am Federbein durch ein Kugellager Nr. 142040 ersetzt werden.
 - Ⓔ El rodamiento de agujas debe sustituirse por el rodamiento nº 142040.
 - Ⓟ O rolamento de agulhas original tem que ser substituído por um rolamento ref. 142040.

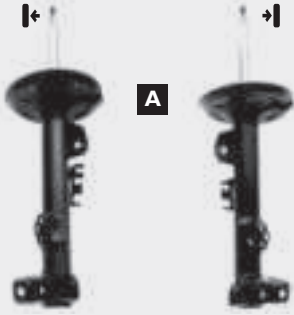
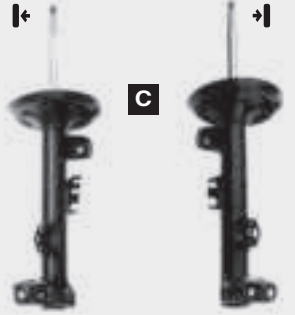
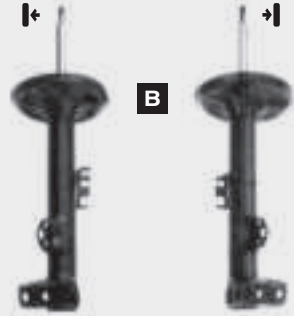
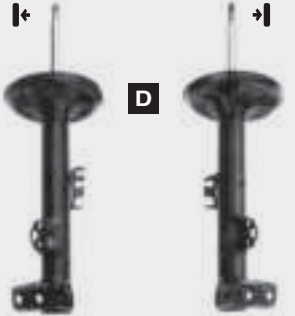

<p>6</p> 	<p>A X = 264 mm</p> <p>B X = 250 mm</p> <p>C X = 271 mm</p>		<p>D Y = 157 mm</p> <p>E Y = 181 mm</p>
---	--	--	---

- | | |
|--|--|
| <p>7 A</p> <ul style="list-style-type: none"> Ⓘ Installare su montante Mac-Pherson di diametro esterno 45 mm. Ⓖ Fits vehicles with outside strut diameter of 45 mm. Ⓕ Pour une jamb dont le diamètre extérieur est de 45 mm. Ⓓ Bei einem äusseren federbeindurchmesser von 45 mm. verwenden. Ⓔ Para vehículos con diámetro exterior de columna de 45 mm. Ⓟ Para uma escora cujo diâmetro exterior é de 45 mm. | <p>B</p> <ul style="list-style-type: none"> Ⓘ Installare su montante Mac-Pherson di diametro esterno 51 mm. Ⓖ Fits vehicles with outside strut diameter of 51 mm. Ⓕ Pour une jamb dont le diamètre extérieur est de 51 mm. Ⓓ Bei einem äusseren federbeindurchmesser von 51 mm. verwenden. Ⓔ Para vehículos con diámetro exterior de columna de 51 mm. Ⓟ Para uma escora cujo diâmetro exterior é de 51 mm. |
|--|--|

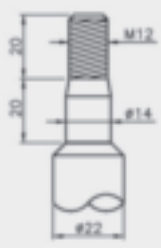
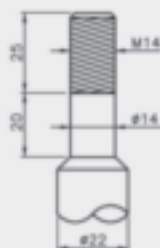
<p>8</p> <p>A</p> 	<p>C</p> 
<p>B</p> 	<p>D</p> 

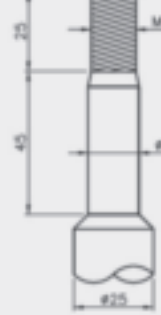
<p>9 A</p> 	<p>B</p> 	<p>C</p> 	<p>D</p> 
---	---	--	---

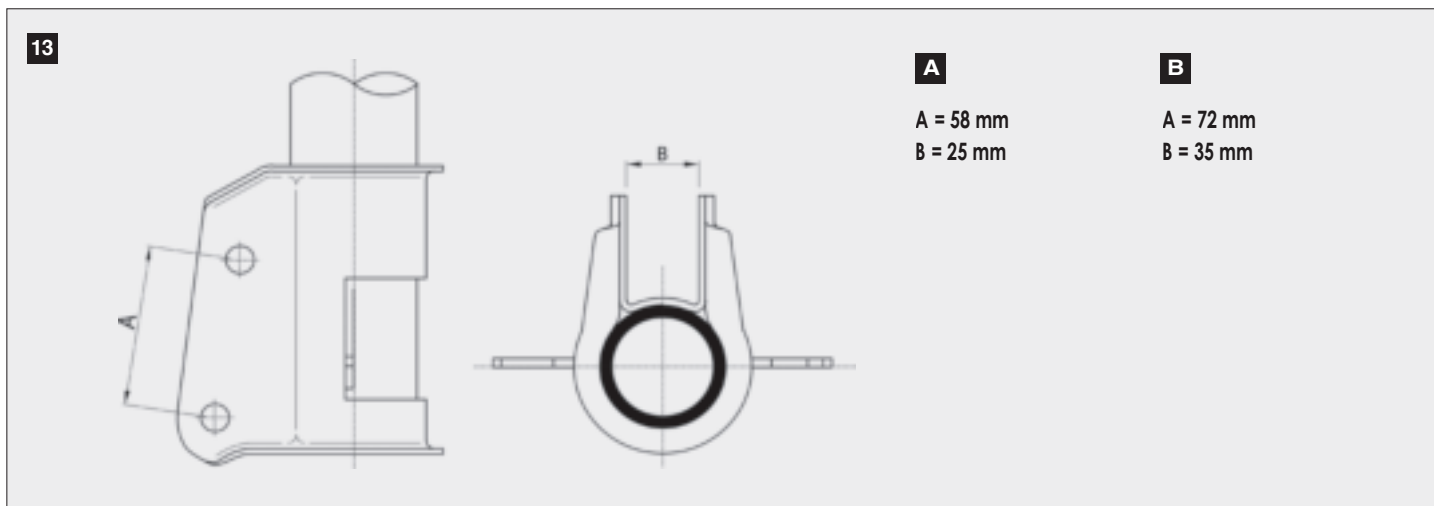
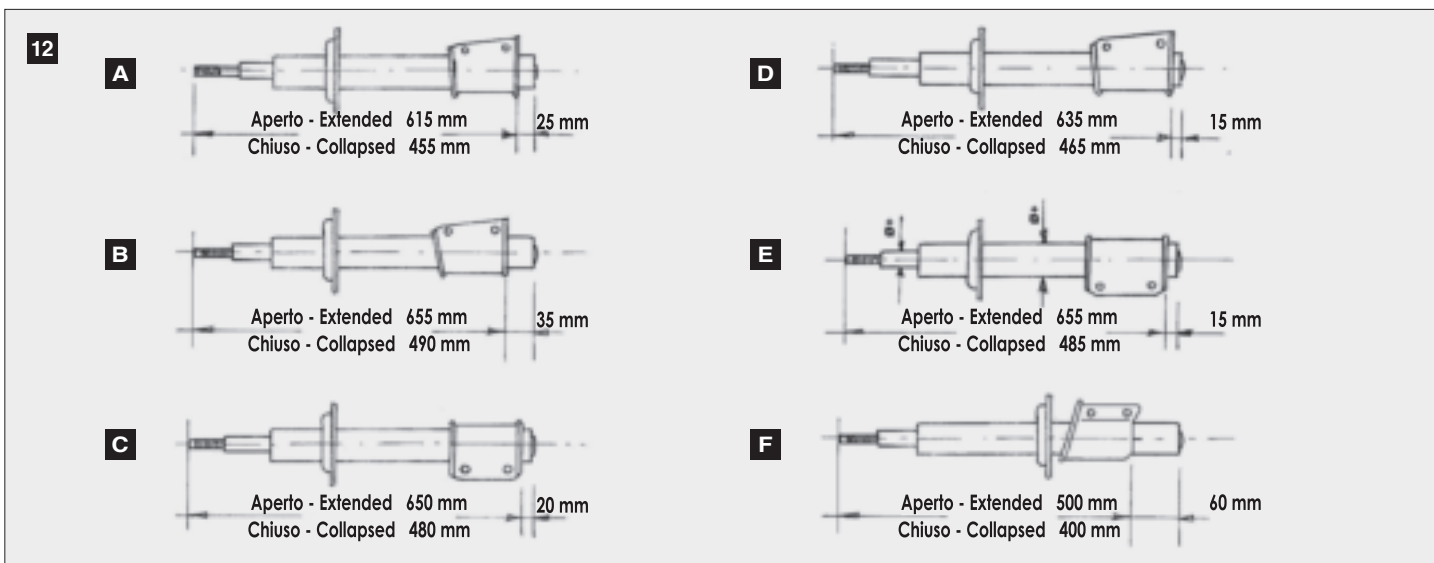
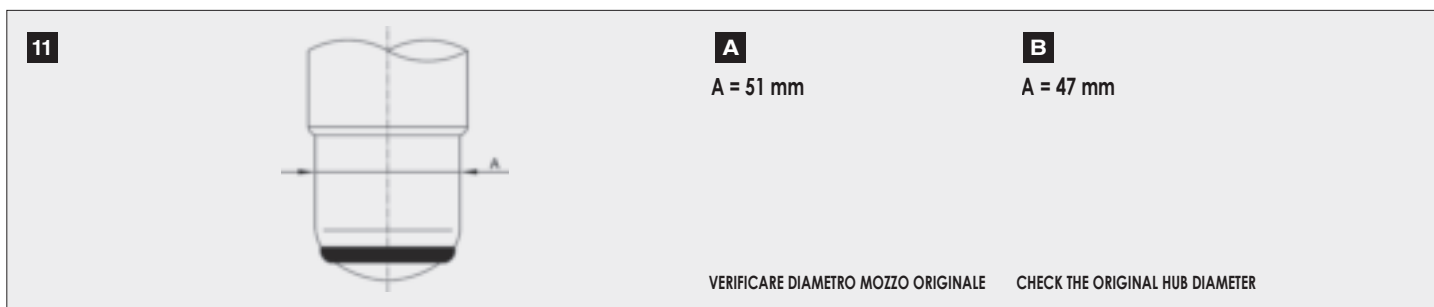
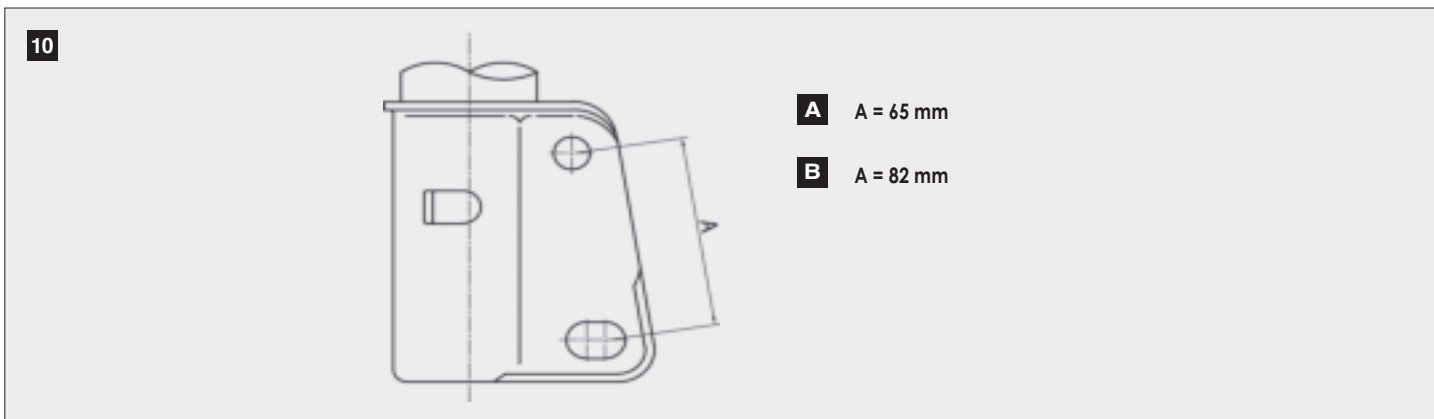

14

A	B	C	D	E	F	G
A = 10 mm.	A = 16 mm.	A = 10 mm.	A = 16 mm.	A = 16 mm.	A = 16 mm.	A = 16 mm.
B = 16 mm.	B = 10 mm.	B = 16 mm.	B = 16 mm.	B = 16 mm.	B = 16 mm.	B = 16 mm.
La = 570 mm.	La = 535 mm.	La = 590 mm.	La = 490 mm.	La = 470 mm.	La = 465 mm.	La = 455 mm.
Lc = 360 mm.	Lc = 342 mm.	Lc = 367 mm.	Lc = 320 mm.	Lc = 300 mm.	Lc = 300 mm.	Lc = 315 mm.

15

OE REINFORCED

- 16**
- Ⓘ Ammortizzatore allungato da installare esclusivamente con la molla di carico 10883 o 10884
 - Ⓞ Extended shock absorber to install exclusively with auxiliary spring 10883 or 10884
 - Ⓕ Ammortiseur allongé de installer avec ressort compensateurs 10883 ou 10884
 - Ⓓ Verlängertstoßdämpfer installations ausschließlich mit nivellierungsfedersätze 10883 oder 10884
 - Ⓔ Amortiguador prolongado da instalar con la muella compesadora 10883 o 10884
 - Ⓟ Amortecedore alongado para instalar com mola de carga 10883 ou 10884

17

18

A	B	C	D
A = 12 mm.	A = 12 mm.	A = 12 mm.	A = 12 mm.
B = 12 mm.	B = 12 mm.	B = 14 mm.	B = 14 mm.
La = 380 mm.	La = 400 mm.	La = 395 mm.	La = 395 mm.
Lc = 270 mm.	Lc = 283 mm.	Lc = 280 mm.	Lc = 280 mm.

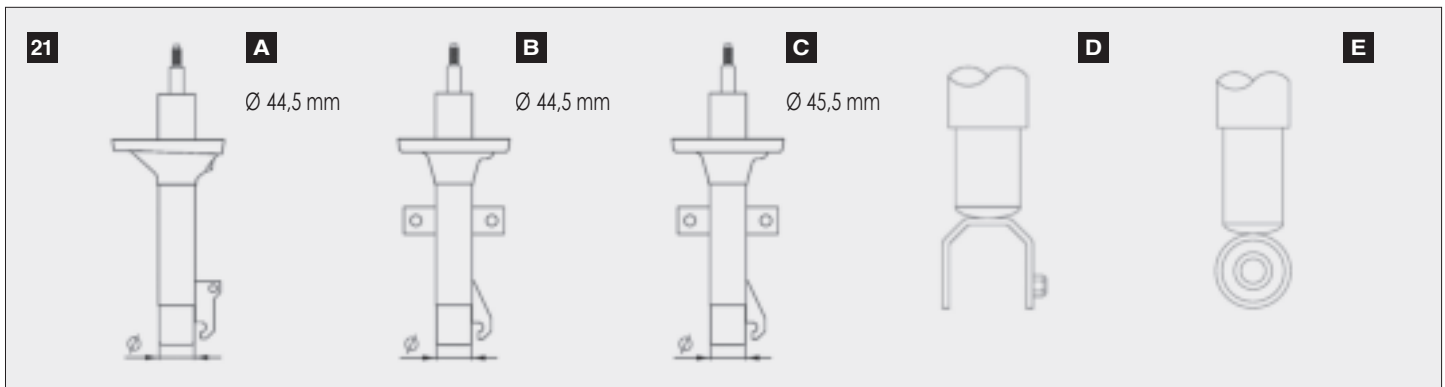
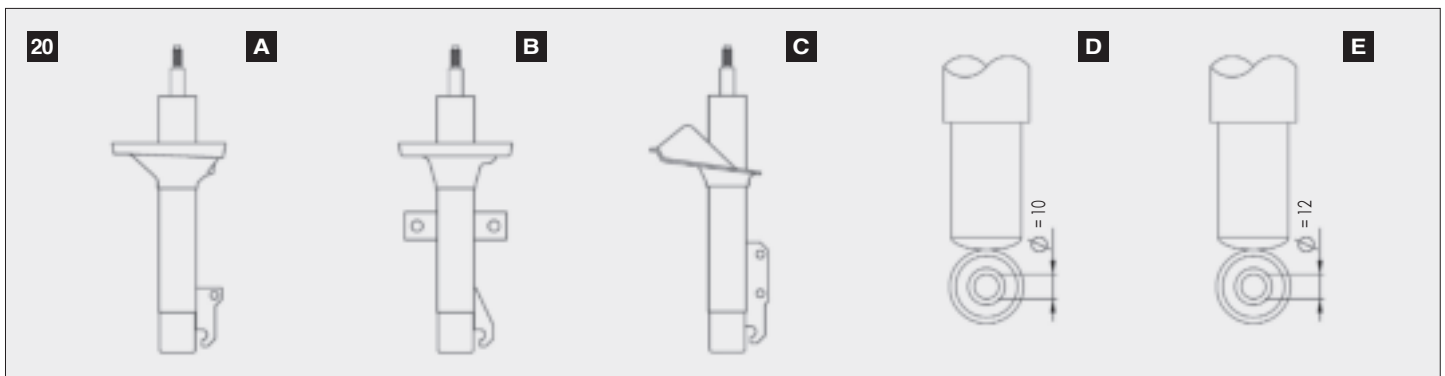

- | | |
|--|--|
| <p>22 A</p> <ul style="list-style-type: none"> ⓐ Piattello base molla rotondo ⓑ Round spring seat ⓒ Plat de ressort rond ⓓ Rund Platfeder ⓔ Plato de muella redondo ⓖ Assento de mola redondo | <p>B</p> <ul style="list-style-type: none"> ⓐ Piattello base molla ovale ⓑ Oval spring seat ⓒ Plat de ressort oval ⓓ Oval Platfeder ⓔ Plato de muella oval ⓖ Assento de mola oval |
|--|--|

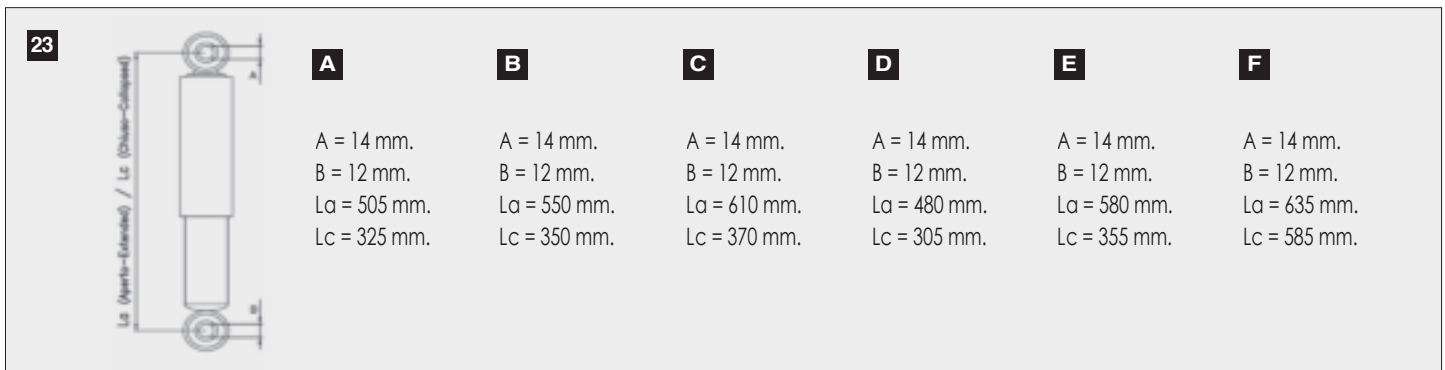

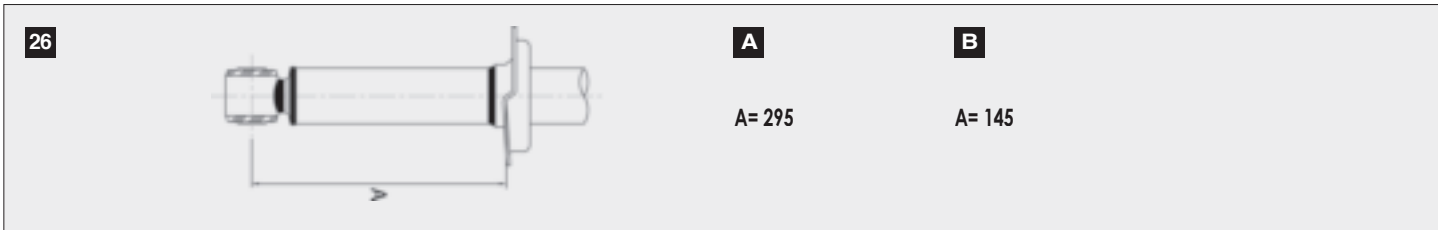
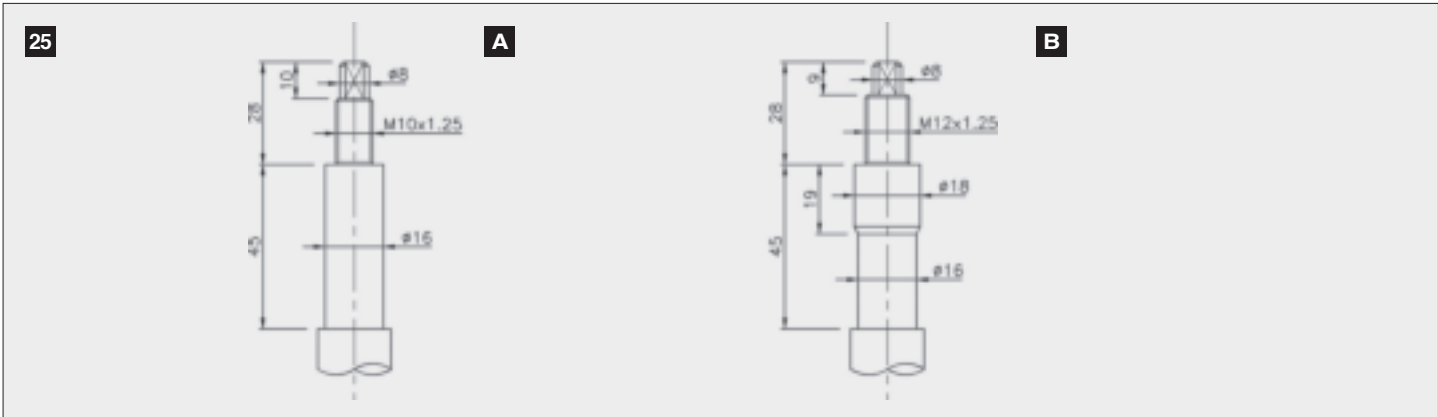

	A	B	C	D	E	F		
	A = 16 mm.	A = 12 mm.	A = 16 mm.	A = 16 mm.	A = 16 mm.	A = 16 mm.	A = 16 mm.	
	B = 16 mm.	B = 12 mm.	B = 16 mm.	B = 16 mm.	B = 16 mm.	B = 16 mm.	B = 16 mm.	
	La = 504 mm.	La = 576 mm.	La = 416 mm.	La = 442 mm.	La = 587 mm.	La = 407 mm.	La = 428 mm.	La = 568 mm.
	Lc = 312 mm.	Lc = 352 mm.	Lc = 266 mm.	Lc = 280 mm.	Lc = 355 mm.	Lc = 325 mm.	Lc = 280 mm.	Lc = 348 mm.

- 28**
- Ⓘ 4 Ammortizzatori posteriori
 - ⒼⒷ 4 Rear shock absorbers
 - Ⓕ 4 Ammortisseurs postérieur
 - Ⓓ 4 Hintere Stoßdämpfer
 - Ⓔ 4 Amortiguadores trasero
 - Ⓖ 4 Amortecedores traseira

29



A	B
A = 46 mm	A = 40 mm

30



A	B	C	D
A = 12 mm. B = 12 mm. La = 588 mm. Lc = 350 mm.	A = 14 mm. B = 12 mm. La = 485 mm. Lc = 300 mm.	A = 14 mm. B = 14 mm. La = 588 mm. Lc = 350 mm.	A = 14 mm. B = 14 mm. La = 626 mm. Lc = 370 mm.

31



A	B
X = 215 mm. X = 244 mm.	 ø = 93 mm. ø = 103 mm.

32



A	B
ø = 152 mm.	ø = 170 mm.

33



A	B
A = 10 mm.	A = 15 mm.

- | | |
|--|---|
| <p>34 A ① Ammortizzatore senza fissaggio della barra stabilizzatrice.
 ② Shock without drop link bracket.
 ③ Amortisseur sans fixation de la barre stabilisatrice.
 ④ Stoßdämpfer ohne Stabilisierungsstangenhalterung.
 ⑤ Amortiguador sin fijación de barra estabilizadora.
 ⑥ Amortecedor sem fixação de barra estabilizadora.</p> | <p>B ① Ammortizzatore con fissaggio della barra stabilizzatrice.
 ② Shock with drop link bracket.
 ③ Amortisseur avec fixation de la barre stabilisatrice.
 ④ Stoßdämpfer mit Stabilisierungsstangenhalterung.
 ⑤ Amortiguador con fijación de barra estabilizadora.
 ⑥ Amortecedor com fixação de barra estabilizadora.</p> |
|--|---|

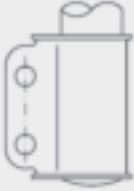

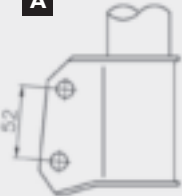
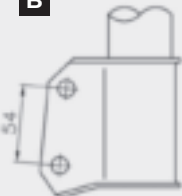
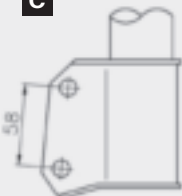
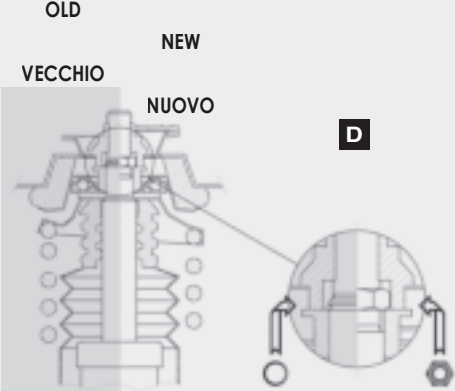
<p>35</p>  <p>A O.E.: 77 00 732 743 77 00 732 744 77 00 807 874 77 02 145 522 77 02 145 523</p>	<p>B</p>  <p>B O.E.: 77 00 786 597 77 00 807 873 77 02 150 468</p>
--	--

<p>36 A</p>  <p>O.E.: 77 00 808 490 77 00 816 045 77 00 823 130 77 00 828 680 77 00 838 084</p>	<p>B</p>  <p>O.E.: 77 00 808 491 / 77 00 808 492 77 00 816 046 / 77 00 823 129 77 00 823 131 / 77 00 828 681 77 00 828 682 / 77 00 828 683 77 00 828 684 / 77 00 838 083 77 00 838 085 / 77 00 838 086 77 00 838 087 / 77 00 838 088</p>	<p>C</p>  <p>O.E.: 77 00 423 726 77 00 423 727 77 00 423 729</p>	<p>D</p>  <p>OLD NEW VECCHIO NUOVO</p>
---	--	--	--

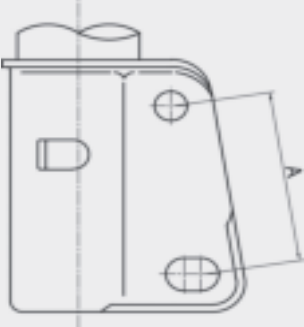
37



A	A = 60 mm	Body Ø47
B	A = 75 mm	Body Ø52

<p>38 A</p>  <p>34 mm.</p>	<p>B</p>  <p>24 mm.</p>
--	---

- 39** **I** Sospensione anteriore senza barra di torsione. **D** Vorderaufhängung ohne Torsionsstab.
GB Front suspension without torsion bar. **E** Suspensión delantera sin barra de torsión.
F Train avant sans barre de torsion. **P** Suspensão dianteira sem barra estabilizadora.

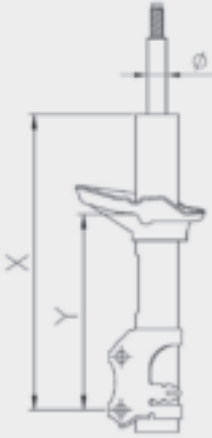
40

- A** X = 320 mm Y = 228 mm Ø = 20 mm
B X = 342 mm Y = 228 mm Ø = 22 mm
C X = 336 mm Y = 228 mm Ø = 20 mm
D X = 318 mm Y = 228 mm Ø = 22 mm
E X = 336 mm Y = 228 mm Ø = 22 mm
F X = 340 mm Y = 250 mm Ø = 22 mm

- 41** **I** Se le cartucce originali sono a gas, montare l'adattatore Volvo rif. 122 94 23 sotto la cartuccia.
GB If the original insert are gas pressurized, place Volvo spacer n° 122 94 23 underneath the insert.
F Si les cartouches d'origine sont à gaz, montez l'adaptateur Volvo Réf. 122 94 23 sous la cartouche.
D Wenn Original-Gasdruckeinsätze montiert sind, Volvo Adapter Nr. 122 94 23 im Federbein unter den Federbeineinsatz montieren.
E Si los cartuchos originales son de gas presurizado, coloque el adaptador Volvo N° 122 94 23 debajo del cartucho.
P Se as aplicações de origem forem a gás, monte o adaptador Volvo ref. 122 94 23 por baixo da aplicação.

- 42** **I** Se il veicolo è munito di correttore d'assetto, sostituire la molla con una Volvo rif. 122 90 52/3/4.
GB If the vehicle is equipped with a self levelling suspension, replace the spring by a Volvo one N° 122 90 52/3/4.
F Si le véhicule est équipé d'un correcteur d'assiette, remplacez le ressort par un Volvo Réf 122 90 52/3/4.
D Wenn das Fahrzeug mit automatischem Niveau-Ausgleich-System versehen ist, Originalfeder durch Volvo Feder Nr. 122 90 52/3/4 ersetzen.
E Si el vehículo está equipado con suspensión autonivelada, sustituya el muelle por un muelle Volvo N° 122 90 52/3/4.
P Se o veículo estiver equipado com uma suspensão autonivelável, substitua a mola por uma Volvo ref. 122 90 52/3/4.

- 43** **I** Se il veicolo è munito di correttore d'assetto, sostituire la molla con una Volvo rif. 135 97 10 o 127 39 77.
GB If the vehicle is equipped with a self levelling suspension, replace the spring by a Volvo one N° 135 97 10 or 127 39 77.
F Si le véhicule est équipé d'un correcteur d'assiette, remplacez le ressort par un Volvo Réf 135 97 10 ou 127 39 77.
D Wenn das Fahrzeug mit automatischem Niveau-Ausgleich-System versehen ist, Originalfeder durch Volvo Feder Nr. 135 97 10 oder 127 39 77 ersetzen.
E Si el vehículo está equipado con suspensión autonivelada, sustituya el muelle por un muelle Volvo N° 135 97 10 ó 127 39 77.
P Se o veículo estiver equipado com uma suspensão autonivelável, substitua a mola por uma Volvo ref. 135 97 10 ou 127 39 77.

ORDINI: Gli ordini devono pervenire presso la nostra sede a mezzo fax o posta elettronica. Solo in via del tutto eccezionale possono essere accettati ordini verbali, in tal caso si declina ogni responsabilità per inesattezze, incomprensioni o interpretazioni errate. Tutti gli ordini sono subordinati all'approvazione da parte dell'azienda che si riserva la facoltà di accettarli.

PREZZI: Per tutti gli ammortizzatori a catalogo fanno fede i prezzi indicati sul listino in vigore. Tutti i prezzi si intendono IVA esclusa e franco nostro stabilimento. L'azienda si riserva la facoltà di modificare i prezzi convenuti senza obbligo di preavviso. Invitiamo la gentile clientela a verificare tutte le condizioni indicate nella conferma d'ordine.

CONSEGNE: Tutti i termini di consegna del materiale ordinato, anche se indicati nella conferma d'ordine, sono da considerarsi indicativi e non impegnativi per l'azienda. I ritardi o le mancate consegne del materiale eventualmente non disponibile presso i nostri magazzini non potranno dare consenso all'annullamento dell'ordine in corso, né potranno costituire pretesto per risarcimento di danni. Eventuali deroghe alle presenti condizioni di consegna devono essere concordate ed accettate per iscritto da entrambe le parti.

CONFEZIONAMENTO: Tutto il materiale verrà consegnato adeguatamente confezionato, secondo gli standard previsti dall'azienda. Eventuali variazioni in questo senso devono essere concordate con l'ufficio commerciale e regolamentate per iscritto. Le spese di confezionamento si intendono comprese nel prezzo degli ammortizzatori.

IMBALLO: L'imballo verrà effettuato secondo gli standard in uso e fatturato al costo. Eventuali variazioni in tal senso devono essere preventivamente concordate per iscritto da entrambe le parti.

SPEDIZIONE: La merce viaggia sempre a rischio e pericolo del committente, anche se spedita in porto franco. In mancanza di precise indicazioni del committente tutto il materiale verrà spedito con il mezzo ritenuto più opportuno. La nostra responsabilità, per tutto il materiale spedito, si conclude alla consegna del medesimo al vettore. Eventuali danni, furti, manomissioni o quant'altro possa arrecare inconvenienti al committente vanno gestiti direttamente dallo stesso con il trasportatore. Il destinatario rimane comunque vincolato al pagamento totale della merce spedita. L'azienda non risponde per eventuali ritardi nelle consegne derivanti da cause di forza maggiore o da circostanze dipendenti dal vettore.

RECLAMI: Eventuali reclami, dovuti a discordanze riscontrate nella documentazione, o di qualsiasi altra natura, devono essere notificati entro e non oltre 8 giorni dalla data di ricevimento del materiale a mezzo lettera raccomandata. Fanno eccezione tutti i reclami considerati motivo di garanzia per i quali rimandiamo alla sezione "garanzia del prodotto".

PAGAMENTI: Il pagamento delle fatture deve essere fatto entro il termine prescritto ed indicato in fattura. Il mancato rispetto dei termini di pagamento comporterà l'addebito delle spese di insoluto e degli interessi di mora, calcolati in base al tasso EURIBOR maggiorato di 6 punti; renderà inoltre le altre fatture in corso, ancorché non scadute, immediatamente esigibili. Il mancato pagamento autorizza pure l'azienda a sospendere tutte le forniture con effetto immediato. I pagamenti sono validi solo se effettuati, direttamente all'azienda o a persona da noi espressamente autorizzata, secondo le disposizioni concordate con il nostro ufficio amministrativo.

CONTROVERSIE: Per qualsiasi controversia, nessuna esclusa, sarà competente il Foro di Treviso.

TUTELA DELLA PRIVACY: Tutti i dati relativi al committente, ivi compresi quelli inerenti gli ordinativi e le condizioni in uso, saranno custoditi ed elaborati, anche con sistemi informatici, per soli scopi statistici, adempimenti fiscali e di legge e per l'invio di materiale informativo o promozionale, secondo quanto stabilito dalla legge 675/96 e D.L.196/2003 in materia.

Tutte le condizioni riportate, ivi incluse quelle seguenti, relative alla garanzia del prodotto, si ritengono accettate integralmente al momento del ricevimento dell'ordine, sia esso scritto o verbale.

GARANZIA DEL PRODOTTO

L'intera gamma **VITAL SUSPENSIONS** è offerta con una garanzia di due anni. Tale garanzia si ritiene subordinata alle condizioni, elencate di seguito, che l'acquirente è tenuto a verificare e rispettare durante l'intero periodo garantito.

CONDIZIONI DI GARANZIA: La garanzia di due anni applicata a tutti gli ammortizzatori copre esclusivamente le non conformità, verificate sugli ammortizzatori stessi, relativamente a vizi di fabbricazione e di funzionamento.

La garanzia del prodotto, in quanto tale, vale esclusivamente nei termini di sostituzione gratuita del materiale riconosciuto difettoso.

Tale garanzia inoltre si ritiene valida per il solo prodotto riconosciuto non conforme, pertanto non prevede estensioni a coppie o insiemi di ammortizzatori, anche se installati sul medesimo veicolo.

Non sussistono risarcimenti, o pretese di qualsiasi natura, ulteriori a quelle precedentemente esposte; anche qualora direttamente o indirettamente collegate alla non conformità del prodotto.

La garanzia non comprende :

- La normale usura dell'ammortizzatore.
- I danni derivanti da incidenti, di qualsivoglia natura, subiti dal veicolo.
- I danni provocati all'ammortizzatore da un montaggio scorretto o dall'impiego di attrezzature non idonee (es. stelo rovinato dalle pinze).
- I danni provocati dall'utilizzo dell'ammortizzatore su veicoli diversi da quelli per i quali è stato realizzato, in conformità a quanto riportato sullo stesso catalogo corrente.
- I danni causati da manomissioni di qualsiasi natura apportate all'ammortizzatore.
- Le non conformità dovute all'impiego dell'ammortizzatore su sistemi di sospensione speciali per i quali non è previsto il suo impiego (sospensioni autolivellanti, sospensioni regolabili elettronicamente, ecc.).
- I danni arrecati all'ammortizzatore dall'utilizzo del veicolo in competizioni automobilistiche di qualsiasi natura.
- I danni causati all'ammortizzatore dal montaggio su sospensioni con caratteristiche e componenti diversi dall'originale, quali ad esempio molle tagliate, tamponi e parapolvere modificati o eliminati, ecc.
- Eventuali montaggi abbinati a molle di assetto sportivo, eccezion fatta per le molle di assetto di nostra produzione e per i pacchetti sportivi forniti dalla casa produttrice.
- I danni arrecati da manutenzione scorretta o insufficiente del mezzo.

RICHIESTA DI GARANZIA: La richiesta di garanzia del prodotto deve essere presentata al concessionario presso il quale è stato acquistato.

Il concessionario stesso provvederà direttamente, dopo l'accertamento della non conformità, alla sostituzione del materiale difettoso.

Al concessionario dovranno essere consegnati tutti i dati indispensabili alla verifica della garanzia, e più precisamente :

- Estremi dell'acquirente o dell'officina di montaggio.
- Codice dell'articolo non conforme.
- Quantità non conforme.
- Data di acquisto e di montaggio.
- Dati di riconoscimento del veicolo.
- Condizione del veicolo al momento del montaggio.
- Descrizione dettagliata della non conformità.

Il concessionario successivamente avrà cura di trasmettere i suddetti dati all'ufficio di Controllo Qualità del produttore il quale avvierà il processo di verifica.

Dopo l'acquisizione dei dati forniti dal cliente verrà data l'autorizzazione al reso del materiale difettoso.

Il prodotto ritenuto non conforme dovrà quindi pervenire presso di noi, in porto franco, corredato di documento in conto garanzia (qualora il materiale non fosse spedito dal distributore la bolla dovrà recare come intestatario il distributore stesso).

Sarà respinto tutto il materiale spedito senza il benestare a procedere da parte dell'azienda.

Il ripristino, la sostituzione o l'accredito del prodotto in garanzia sarà fatto solo dopo l'accertamento della non conformità da parte del personale tecnico addetto al controllo qualità, nel rispetto delle condizioni sopra elencate. Lo stesso personale sarà a disposizione del cliente per ogni chiarimento in merito.

La possibilità di sostituzione immediata del materiale ritenuto non conforme, al fine di evitare il fermo del veicolo, è prerogativa esclusiva del distributore, il quale può eventualmente adottarla a sua discrezione, rimanendo tuttavia non vincolata alle condizioni generali di garanzia del prodotto.

Per conoscenza segnaliamo che tutti i reclami ed i certificati di garanzia verranno archiviati, unitamente ai dati a nostra disposizione (cliente, non conformità, riferimenti produttivi, ecc.), per disporne in qualunque momento e per verificare l'utilità di azioni correttive eventualmente necessarie su alcuni prodotti.

Tutti i dati dei clienti verranno comunque custoditi ed elaborati esclusivamente per attività informatiche e di ricerca interne all'azienda, adempimenti di legge ed eventuale invio di materiale informativo-promozionale; in conformità a quanto richiesto dalla legge 675/96 e D.L.196/2003 sulla tutela della privacy.

PURCHASE ORDERS: Orders must be forwarded to our offices by fax or e-mail. Verbal orders will be accepted only in very special conditions, in which case we shall not be held responsible for inexactness, misunderstandings or erroneous interpretation.

Orders are subject to approval by our offices who reserves the right to accept them.

PRICES: For all shock absorbers in our catalogue the prices applied are those contained in the current up to date price-lists.

All prices do not include VAT and are for goods available ex works.

We reserve the right to make changes to the prices agreed without notice. We therefore invite customers to check all conditions at the time of our order confirmation.

DELIVERY: All delivery times provided for the goods that have been ordered, even when stated in our order confirmation, should be considered approximate and are not binding to the supplier.

Any delays or failure to deliver any goods not currently available in our warehouses shall not entitle cancellation of the order in progress and give grounds for an indemnification claim.

Any variation to these delivery terms shall be agreed and accepted in writing by both parties.

PACKAGING: All goods are delivered suitably packed, according to our company's standards.

Any variations shall be agreed with our sales department and made in writing.

The cost of packaging is included in the price of the shock absorber.

PACKING: Goods are packed by our company according to our standards and invoiced according to cost.

Any variations shall be agreed writing by both parties.

DELIVERY: Goods travel always at the customer's own risk, even when delivered duty paid.

Unless specifically stated by the customer, the goods will be delivered with the means of transport we consider most appropriate.

Our liability regarding all the goods dispatched ends upon their delivery to the forwarding agent.

Any damage, theft, tampering with or any other inconveniences caused to the customer shall be handled by the latter with the forwarding agent.

The consignee shall always pay the total amount of the goods delivered.

We shall not be held responsible for any delays due to circumstances beyond our control and/or natural calamities, or other circumstances depending on the forwarding agent.

COMPLAINTS: Any complaints due to discrepancies in the documents or of any other kind, shall be notified by registered letter no later than 8 days after receipt of the goods.

This clause does not apply in the case of complaints considered warranty conditions regarding this please see the "Product warranty" section.

PAYMENTS: Invoices shall be paid within the prescribed term stated in the invoice. Non-compliance with the terms of payment shall cause any unsettled payment expenses to be charged interest for delayed payment, calculated according to the EURIBOR rate plus 6% and due for immediate payment even if not overdue.

Any failure to settle payments authorises us to suspend all deliveries immediately. Payments are valid only when made directly to our company or to any person authorised by the company in agreement with our administration.

DISPUTES: Disputes of any kind shall be submitted to the jurisdiction of the Court of Treviso.

PRIVACY: All data concerning customers, including any information concerning orders and terms applied, shall be stored and processed, even electronically solely for statistical purposes, for legal or fiscal requirements and for dispatching informative or promotional material as prescribed by the relevant Italian Law on Privacy.

PRODUCT WARRANTY

Our whole range of **VITAL SUSPENSIONS** is offered with a two-year warranty. The warranty is subject to the conditions stated below that the purchaser must check and respect for the entire warranty period.

WARRANTY CONDITIONS: The two-year warranty is applied to shock absorbers in the "improved" range and covers exclusively non-compliance assessed on the shock absorbers due to manufacturing or working defects.

Our product warranty is applied exclusively in terms of free of charge replacement goods acknowledged as being faulty.

In addition, the warranty applies in the case of a single product acknowledged as non-conforming and therefore cannot be extended to pairs or multiple shock absorbers, even when they are installed on the same vehicle.

No compensation or claims of any kind besides those aforementioned are acceptable even when directly or indirectly related to the non-conforming component.

The warranty does not include:

- Normal wear and tear of shock absorbers
- Damage caused by accidents of any kind involving the vehicle.
- Damage caused to the shock absorber by improper installation or by the use of unsuitable equipment (e.g. piston rod ruined by pincers).
- Damage caused by using the shock absorber on a vehicle other than the model the shock absorber has been made for as mentioned in our current catalogue.
- Damage caused by any kind of tampering with the shock absorber.
- Non-compliance due to the use of the shock absorber in special suspension systems to which it is not suited (self-levelling suspensions, electronically adjustable suspension, etc.).
- Damage cause to the shock absorber by the use of the vehicle in any kind of car competitions.
- Damage caused to the shock absorber by installation on suspension using features and components differing from the original, such as cut springs, modified or eliminated rebound bumpers and dust covers, etc.
- Any installation combined with sports springs, apart from our own series and from original sports kits supplied by the manufacturer.
- Damage due to improper or insufficient maintenance of the vehicle.

WARRANTY REQUEST: The product warranty request must be forwarded to the dealer where it has been purchased.

After assessing non-compliance the dealer shall replace the faulty goods immediately.

It is necessary to provide the dealer with all the information needed to check the warranty, i.e.:

- Customer or installation shop details.
- Non-conforming article part number.
- Non-conforming quantity.
- Date of purchase and installation.
- Vehicle identification data.
- Vehicle conditions at the time of installation.
- Detailed description of non-compliance.

The dealer shall then communicate the information above to the manufacturer's Quality Control Service, which initiates the control process.

On receipt of the information provided by the customer the return of the faulty goods will be authorised.

Any products considered non-conforming shall therefore be returned to us carriage paid together with a warranty delivery note (if the goods are not returned via the distributor the delivery note shall be sent with the distributor as consignee).

Any goods returned without our approval shall be rejected.

The repair, replacement of our credit note for the product under warranty shall occur only once non-compliance has been assessed by our quality control technicians in the full respect of the above-mentioned conditions.

Our staff is at customer's disposal for any explanations regarding these matters.

The possibility of immediate replacement the goods considered non-conforming in prevent stopping the vehicle, depends exclusively on the distributor who proceed at his own discretion, remaining however not bound by the product general warranty conditions. We inform you that all complaints and warranty certificates will be filed together with the information available to us (customer, non-compliance, production references, etc.) so that we can use them at any time and to assess the utility of any corrective actions required for products.

All customer data will be filed and processed only for internal information and research activities, legal or fiscal requirements and dispatch of informative and promotional material in compliance with the Italian Law concerning the safeguard of privacy.

All the aforesaid conditions are considered accepted in full upon receipt of a written or verbal order.

PARAOLIO SCOPPIATO

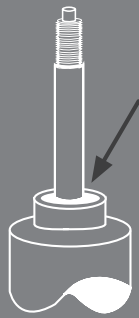

Ammortizzatore che presenta una slabbratura della guarnizione di tenuta con conseguente perdita di olio e quindi rottura dell'ammortizzatore, dovuta alla NON sostituzione del tampone di fine corsa deteriorato e quindi al non rispetto del suo corretto funzionamento come assorbitore d'urti.

A shock absorber with burring on the gasket and consequent oil leak, which would lead to the shock absorber breaking. This is caused by failure to replace the worn rubber rebound bumper, which is unable to absorb any impact.

SFONDAMENTO DI FINECORSA

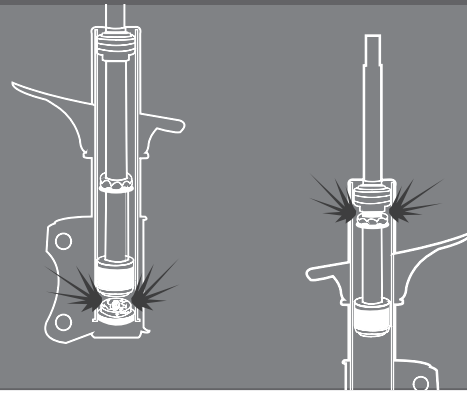

Sfondamento della valvola di fondo dell'ammortizzatore e del pistone a causa del continuo lavoro a fine corsa inferiore dell'ammortizzatore causato da percorrenza in strade dissestate e da continui dossi rompi velocità con conseguente deterioramento del tampone di fine corsa e del cedimento progressivo della molla di sospensione. Risultato perdita olio, effetto elastico e non funzionamento dell'ammortizzatore.

A smashed bottom valve and piston rod due to continued working of the shock absorber at the bottom, caused by uneven road surfaces or speed humps, which damage the rubber rebound bumper and gradually cause the suspension spring to give way. The result is leaking oil, reduced elastic effect and ineffective shock absorber.



PRINCIPALI CAUSE DI DANNEGGIAMENTO NON IMPUTABILI A DIFETTOSITÀ DEL PRODOTTO

PRINCIPLE DEFECTS DUE TO IMPROPER HANDLING OF PRODCUT

ROTTURA TAMPONE DI FINECORSA

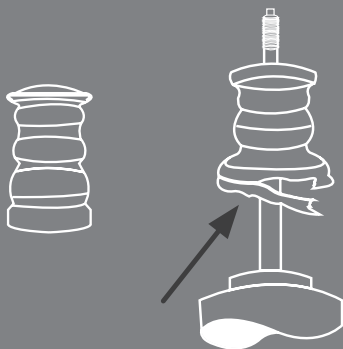

Ammortizzatore danneggiato per usura del tampone di fine corsa, dove soprattutto con il nuovo e massiccio impiego da parte dei costruttori del poliuretano microcellulare che evita in parte anche il sovraccarico del mezzo, il tampone si deteriora rapidamente sia come sfrangiatura che come rigidità con conseguente rottura dell'ammortizzatore per urti di fine corsa inferiore.

A shock absorber damaged by a worn rubber rebound bumper due to the massive use by manufacturers of microcell polyurethane to make the bumpers, which avoid part of the shock absorber overload. With excessive work the bumper deteriorates, disintegrates and becomes hard, and therefore the shock absorber breaks due to closing impact.

ROTTURA OCCHIELLI E PERNI

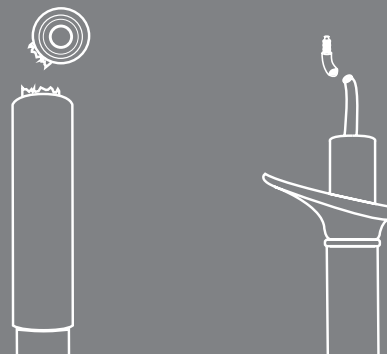

Ammortizzatore che presenta il distacco dell'occhiello (o del perno) dovuto ad un urto, o nel caso del perno, al non corretto montaggio con il giusto serraggio di coppia eseguito con le attrezzature non corrette, utilizzando la pistola pneumatica anziché la chiave dinamometrica. Il distacco dell'occhiello può avvenire anche nel caso in cui il fissaggio dell'ammortizzatore sia stato fatto ancora a veicolo sollevato, anziché con le ruote appoggiate al terreno e quindi con l'ammortizzatore nella corretta posizione di lavoro.

A shock absorber with a broken grommet (or pin), caused by a collision or incorrectly mounting the pin using the wrong tools (e.g. pneumatic screwdriver instead of a torque wrench). The grommet could also detach when the shock absorber has been mounted with the vehicle lifted off the ground and not with the wheels on the ground, which is the correct position to work the shock absorber.

FILETTATURA ROVINATA



Ammortizzatore che presenta il filetto rovinato, in quanto nel montaggio non è stato utilizzato il KIT di viti corredato, bensì un dado di passo diverso da quello fornito, e soprattutto perché si è utilizzato la pistola pneumatica e non invece la chiave dinamometrica.

A shock absorber with ruined thread, due to being mounted without using the supplied screws, but just a nut with a different pitch to the one supplied. Using a pneumatic screwdriver instead of a torque wrench can also cause this damage.

AMMORTIZZATORE STORTO



Ammortizzatore che si presenta piegato, o solo con l'albero storto, oppure il corpo piegato; normalmente questo avviene nel caso dell'albero storto, quando il veicolo urta uno scalino nella strada, mentre la piegatura del corpo dell'ammortizzatore nel caso di incidente più o meno marcato.

A shock absorber with twisted bracket, body or pin. If the piston is twisted it is normally due to impact with a kerb, while a twisted body is caused by a more serious accident.

FORI ATTACCO MODIFICATI

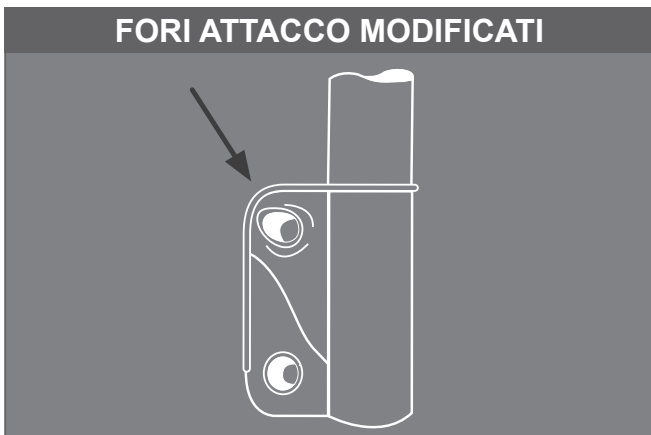

Ammortizzatore che presenta una allargatura manuale del foro di attacco al mozzo ruota in fase di controllo della geometria del veicolo, dovuto principalmente a fattori accidentali che il veicolo ha subito sulla strada, come incidenti e urti vari con conseguente spostamento degli assi di camber.

The shock absorber has a manual widening of the wheel hub attachment hole during alignment, which is caused by road accidents that cause the camber axle to move.

STELO ROVINATO E ARRUGGINITO



Superficie cromata dello stelo rovinata da ammaccature, botte e ruggine con conseguente perdita di olio attraverso il paraolio, difetto questo dovuto nella fase di montaggio dal non corretto fissaggio e protezione del soffietto parapolvere e del tampone di fine corsa.

The piston rod chrome-plated surface is ruined by dents, knocks and rust, with oil leaking through the oil retainer. This fault is caused by incorrectly mounting the rubber rebound bumper and the dust cover.

ALBERO ROVINATO CON LA PINZA



Ammortizzatore che presenta l'albero cromato con evidenti segni di graffiatura della superficie cromata, con conseguente perdita di olio e gas ogni qual volta la parte danneggiata entra nella guarnizione a tenuta di gomma. Danno causato dal non corretto impiego di utensili idonei al montaggio degli ammortizzatori.

A shock absorber with clear signs of scratching on the chrome plated surface of the piston rod, causing oil and gas leaks each time the damaged part enters the gasket. Damage caused by using incorrect tools to mount the shock absorber.

ALBERO USURATO



Ammortizzatore che presenta l'albero cromato danneggiato solo da un lato con evidente zona ovale arrugginita o quantomeno molto lucida e quindi consumata rispetto al resto della cromatura. Pistone quindi sottoposto ad un grosso carico laterale dovuto al non corretto serraggio con ruote a terra e soprattutto al non corretto camber del veicolo.

A shock absorber with the piston rod damaged on just one side, with a clear rusty or shiny oval patch and extensive wear with respect to the rest. The piston rod is subject to heavy side load, caused by incorrect mounting of the wheels on the ground and incorrect alignment.

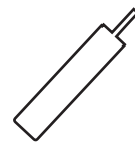
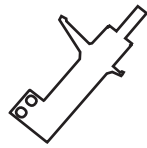

- Tipo di applicazione

- Application type
- Type de application
- Anwendung der Stossdämpfer
- Esquema de anclajes
- Esquema de Montagem
- Bevestiging van de schokdemper
- Anvendelse
- Вид применения

- Sospensione MacPherson

- Complete MacPherson strut
- Jambé de force type MacPherson
- MacPherson komplettes Federbein
- Columna de suspensión
- Coluna de Suspensão MacPherson
- Complete MacPherson veerpool
- Komplet fjerderben
- Подвеска Макферсона

- Cartuccia di ricambio MacPherson

- MacPherson insert
- Cartouche type Mac Pherson
- MacPherson Federbeinsatz
- Cartucho accesorio para columna de suspensión
- Cartucho Substituição para Coluna Suspensão MacPherson
- MacPherson patroon
- Inclsats
- Заменяемый вкладыш стойки Макферсона

- Ammortizzatore con piattello portamolla

- Shock absorber with spring seat
- Amortisseur à siège de ressort
- Stossdämpfer mit Federsitzsteller
- Amortiguador con asiento para muelle
- Amortecedor com Base para Mola
- Schokdemper met veerschotel
- Støddæmper med fjeder skål
- Амортизатор с площадкой для установки пружины

<p>Occhio Eying Oeil Auge Anilla Anilha Oog Øje Отверстие</p>		<p>Occhio Eying Oeil Auge Anilla Anilha Oog Øje Отверстие</p>	<p>Silentblock Barpin Barrette Brücke Pasador Sinobloco Pin Silentblock Втулка</p>		<p>Perno Stud Tige Stift Esparràgo Parafuso Stift Шток</p>	<p>Occhio Eying Oeil Auge Anilla Anilha Oog Øje Отверстие</p>		<p>Speciale Special Spécial Besondere Especial Especial Special Special Специальная</p>	<p>Occhio Eying Oeil Auge Anilla Anilha Oog Øje Отверстие</p>		<p>Perno Stud Tige Stift Esparràgo Parafuso Stift Шток</p>
<p>Perno Stud Tige Stift Esparràgo Parafuso Stift Шток</p>		<p>Silentblock Barpin Barrette Brücke Pasador Sinobloco Pin Silentblock Втулка</p>	<p>Silentblock Barpin Barrette Brücke Pasador Sinobloco Pin Silentblock Втулка</p>		<p>Speciale Special Spécial Besondere Especial Especial Special Special Специальная</p>	<p>Perno Stud Tige Stift Esparràgo Parafuso Stift Шток</p>		<p>Perno Stud Tige Stift Esparràgo Parafuso Stift Шток</p>	<p>Occhio Eying Oeil Auge Anilla Anilha Oog Øje Отверстие</p>		<p>Silentblock Barpin Barrette Brücke Pasador Sinobloco Pin Silentblock Втулка</p>
<p>Silentblock Barpin Barrette Brücke Pasador Sinobloco Pin Silentblock Втулка</p>		<p>Silentblock Barpin Barrette Brücke Pasador Sinobloco Pin Silentblock Втулка</p>	<p>Perno Stud Tige Stift Esparràgo Parafuso Stift Шток</p>		<p>Speciale Special Spécial Besondere Especial Especial Special Special Специальная</p>	<p>Perno Stud Tige Stift Esparràgo Parafuso Stift Шток</p>		<p>Occhio Eying Oeil Auge Anilla Anilha Oog Øje Отверстие</p>		<p>Silentblock Barpin Barrette Brücke Pasador Sinobloco Pin Silentblock Втулка</p>	
<p>Silentblock Barpin Barrette Brücke Pasador Sinobloco Pin Silentblock Втулка</p>		<p>Silentblock Barpin Barrette Brücke Pasador Sinobloco Pin Silentblock Втулка</p>	<p>Perno Stud Tige Stift Esparràgo Parafuso Stift Шток</p>		<p>Speciale Special Spécial Besondere Especial Especial Special Special Специальная</p>	<p>Perno Stud Tige Stift Esparràgo Parafuso Stift Шток</p>		<p>Occhio Eying Oeil Auge Anilla Anilha Oog Øje Отверстие</p>		<p>Silentblock Barpin Barrette Brücke Pasador Sinobloco Pin Silentblock Втулка</p>	

	Tutti i modelli	All models	Tous modèles	Alle Modelle	Todos los modelos	Todos os modelos	Alle modellen	Alle modeller	Все модели
	Berlina 4 porte	Saloon 4 doors	Berline 4 portes	Limousine 4 Türen	Berlina 4 puertas	Berlina 4 portas	Berline 4-deurs	Sedan 4 Døre	Седан 4-х дверный
	Berlina 3-5 porte	Hatchback - Fastback	Berline 3-5 portes	Limousine 3-5 Türen	Berlina 3-5 puertas	Berlina 3-5 portas	Berline 3-5 deurs	Sedan 3-5 Døre	Седан 3-5 дверный
	Station wagon - Familiare	Estate - Station wagon	Break	Kombi - Variant	Familiar	Familiar - Station Wagon	Stationcar	Stationcar	Универсал
	Coupé	Coupé	Coupé	Coupé	Coupé	Coupé	Coupé	Coupe	Купе
	Cabriolet - Spider	Cabriolet, Convertible	Cabriolet, Convertible	Cabriolet	Descapotable	Descapotável	Cabriolet	Cabriolet	Кабриолет / Спайдер
	Fuoristrada	Off road	Tout terrain	Geländewagen	Todo terreno	Todo-o-Terreno	Terreinwagen	Offroad 4x4	Джип
	Van - Furgoncino	Van - Commercial	Utilitaire - Fourgonette	Kastenwagen	Furgoneta - Comercial	Veículo Comercial - Furgão	Bedrijfsvoertuig	Van	Фургон - Грузовик
	Pick-Up	Pick-Up	Pick-Up	Pick-Up	Pick-Up	Pick-Up	Pick-Up	Pickup	Комби
	Autobus - Minibus - Monovolume	Bus - Minibus - Multi purpose vehicle	Bus - Minibus - Monospace	Bus - Kleinbus - Multipurpose vehicle	Autobús - Minibús - Monovolumen	Autocarro - Furgoneta	Bus - Minibus - Monospace	Bus - Minibus	Автобус - Минибус - Многоцелевое транспортное средство
	Ambulanza	Ambulance	Ambulance	Krankenwagen	Ambulancia	Ambulância	Ziekenwagen	Ambulance	Скорая помощь
	Furgone - Camioncino	Van - Truck	Camion - Camionette	LKV - Klainlaster	Camión ligero - Camioneta	Camião - Camioneta	Vrachtwagen - Bestelwagen	Varevogn	Фургон - Грузовик
	Autotelaio cabinato	Châssis cabine	Chassis Cab	Chassis Kabine	Chasis con cabina	Chassis de cabina	Chassis met cabine	Cab chassis/ Føererkabine	Грузопассажирский автомобиль
	Sinistra	Left hand	Gauche	Links	Izquierda	Lado esquerdo	Links	Venstre side	Правый
	Destra	Right hand	Droite	Rechts	Derecha	Lado direito	Rechts	Højre side	Левый
	Kit di protezione	Protection Kit	Kit de protection	Protection kit	Kit de protección	Jogo de Protecção	Beschermings-kit	Monterings kit	Защитный комплект
	Porte	Doors	Portes	Türen	Puertas	Portas	Deuren	Døre	Двери
	Ammortizzatore sterzo	Steering damper	Amortisseur de direction	Lenkungsdämpfer	Amortiguador de dirección	Amortecedor de Direcção	Stuurdemper	Styrdæmper	Амортизатор рулевой рейки
	Sterzo manuale	Without Power Steering	Sans direction assistée	Ohne Servolenkung	Sin dirección asistida	Sem Direcção Assistida	Met Stuurbekrachting	Ingen servostyring	Механическая рулевая рейка
	Servosterzo	Power Steering	Direction assistée	Mit Servolenkung	Dirección asistida	Direcção Assistida	Zonder stuurbekrachting	Servostyring	Рулевая рейка с гидросилителем

	Cambio manuale Manual	transmission Boîte	manuelle Schaltgetriebe	Transmisión manual	Transmissão manual	Manuale versnellingsbak	Manuel gearkasse Механическая	коробка передач	
	Cambio Automatico	Automatic transmission	Boîte automatique	Automatikgetriebe	Transmisión automática	Transmissão automatica	Automatische versnellingsbak	Automat gear kasse	Автоматическая коробка передач
N.D.	Standard	Normal duty	Standard	Standard Ausführung	Normal	Normal	Standaard	Normal	Стандарт
H.D.	Rinforzato	Heavy duty	Renforcé	Verstärkte Ausführung	Reforzado	Reforçado	Versterkt	Forstærket	Усиленный
	Ruota	Wheel	Roue	Rad	Rueda	Roda	Wiel	Hjul	Колесо
Susp.	Sospensione	Suspension	Suspension	Aufhängung	Suspensión	Suspensão	Ophanging	Ophæng/ affjedring	Подвеска
	Sospensioni sportive	Sport suspension	Suspension sport	Sportfederung	Suspensión deportiva	Suspensão Desportiva	Sportvering	Sports- affjedring	Спортивная подвеска
	Sospensione per strade accidentate	For bad road suspension	Suspension pour routes dégradées	Federung für schlechte Straßen Suspensión para	carreteras en mal estado Suspensão para	maus pisos Vering voor slecht	wegdek Affjedring til	dåring vej Усиленная	Подвеска
	Sospensione originale ribassata Original lowered	suspension Suspension	surbaissée Tieferlegung	Suspensión rebajada original	Suspensão rebaixada	Verlaagde ophanging	Forsænket affjedring	Оригинальная спортивная подвеска	
	Sospensione autolivellante	Self levelling suspension	Correcteur d'assiette	Niveau-Ausgleich- System Suspensión	autonivelante Suspensão	autonivelável Ophanging met	niveauregeling Selvregulerende	affjedring	Подвеска авторегулируемая
	Sospensione pneumatica	Air suspension	Suspension pneumatique	Lufffederung	Suspensión neumática	Suspensão pneumática	Pneumatische ophanging	Luffaffjedring	Пневматическая подвеска
	Sospensione idropneumatica	Hydropneumatic suspension	Suspension hydropneumatique	Hydropneumatische Aufhängung	Suspensión hidroneumática	Suspensão hidropneumática	Hydropneumatische ophanging	Hydraulisk affjedring	Гидропневматическая подвеска
	Sospensione regolabile elettronica	Electronically adjustable suspension	Suspension pilotée	Elektronisch einstellbare Federung	Suspensión ajustable electrónicamente	Suspensão regulável electronicamente	Elektronisch gestuurde ophanging	Elektronisk styret affjedring	Электронно- регулируемая подвеска
	Balestra	Leaf spring	Ressort à lames	Blattfeder	Muelle de láminas	Mola de lâminas	Bladveer	Bladffjeder	Рессора
	Molla elicoidale	Coil spring	Ressort hélicoïdale	Schraubfeder	Muelle helicoidal	Mola helicoidal	Spiraalveer	Spiralfjeder	Спиральная пружина
	Ruote singole	Single wheel	Roues simples	Einzelbereifung	Ruedas simples	Rodas simples	Enkel wiel	Enkelt hjul	Одиночные колеса
	Ruote gemelle	Twin wheels	Roues jumelées	Doppelbereifung	Ruedas dobles	Rodas duplas	Dubbele wielen	Tvillingehjul	Двойные колеса
	Asse rigido	Rigid axle	Essieu rigide	Feste Achse	Eje rígido	Eixo rígido	Vaste as	Stiv aksel	Жесткая ось
	Bracci indipendenti	Independant suspension	Suspension indépendat	Unabhängige Aufhängung	Suspensión independiente	Suspensão independente	Onafhankelijke wielophanging	Uafhængig affjedring	Независимые рычаги
	Interasse	Wheel base distance	Empatement	Radstand	Distancia entre ejes	Distância entre eixos	Wielbasis- afstand	Hjulafstand	Межось

	Interasse corto	Short wheelbase	Empattement court	Kurzer Radstand	Distancia entre ejes corta	Dist. curta entre eixos	Korte wielbasis	Kort hjulafstand	Межось короткая	
	Interasse medio	Medium wheelbase	Empattement moyen	Mittlerer Radstand	Distancia entre ejes media	entre eixos Middellange	wielbasis Medium	hjulafstand Межось	средняя	
	Interasse lungo	Long wheelbase	Empattement long	Langer Radstand	Distancia entre ejes larga	Dist. longa entre eixos	Lange wielbasis	Stor hjulafstand	Межось длинная	
	Barra di torsione singola	2 torsion bars	Train à 2 barres de torsion	2 Torsionsstäbe	2 barras de torsión	2 barras estabilizadoras	2 torsiestangen	To torsionsstænger (snoede) Двухторсионный	стабилизатор	
	Doppia barra di torsione	4 torsion bars	Train à 4 barres de torsion	4 Torsionsstäbe	4 barras de torsión	4 barras estabilizadoras	4 torsiestangen	Fire torsionsstænger (snoede)	Четырех торсионный стабилизатор	
	Trazione	Front wheel drive	Traction	Vorderradantrieb	Tracción delantera	Tracção	Voorwielaanrijving	Forhjulstræk	Передний привод	
	Propulsione	Rear wheel drive	Propulsion	Hinterradantrieb	Tracción trasera	Tracção traseira	Achterwielaanrijving	Baghjulstræk	Задний привод	
	Asse anteriore	Front wheels	Roues Avant	Vorderachse	Tren Delantero	Dianteira	Voor	For aksel	Передняя ось	
	Asse posteriore	Rear wheels	Roues Arrière	Hinterachse	Tren Trasero	Traseira	Achter	Bag aksel	Задняя ось	
2WD - 4X2	2 ruote motrici	2 wheel drive	2 roues motrices	2 Radantrieb	2 ruedas motrices	Rodas Motrizes	2 aangedreven wielen	2 hjulstræk	2 ведущих колеса	
4WD - 4X4	4 ruote motrici	4 wheel drive	4 roues motrices	4 Radantrieb	4 ruedas motrices	4 Rodas Motrizes	4 aangedreven wielen	4 hjulstræk	4 ведущих колеса	
excl.	Escluso	Excluding	Exclus	Ausschließlich	Excluyendo	Excepto	Exclusief	Eksklusive	Исключено	
incl.	Incluso	Including	Inclus	Einschließlich	Incluyendo	Inclusivé	Inclusief	Inklusive	Включено	
→Ch. 000	Fino al numero di telaio	To chassis No.	Au chassis N°	Bis zur Fahrgestellnummer	Hasta el número de bastidor	Até ao Chassi N°	Tot chassisn°	Til stelnummer	До номера шасси	
Ch. 000→	Dal numero di telaio	From chassis No.	Du chassis N°	Ab Fahrgestellnummer	Desde el número de bastidor	A Partir do Chassi N°	Vanaf chassisn°	Fra stelnummer	От номера шасси	
O.E.	Riferimento originale	Original Part Number	Référence d'origine	Original Hinweis	Referencia original	Referência original	Origineel nummer Originalt	varenummer Оригинальный	код	
ABS	Sistema antiblocco freni	Antilock Brakes System	Freins antiblocage	Antiblockier systeme	Frenos antibloqueo	ABS	Antiblokkeer remsysteem	Med ABS	Противоблокировочная система тормозов	

